



User Manual



Dynamic 24-PORT MANAGED GIGABIT SWITCH
(DN-80233)

Contents

1.0 Introduction	23
1.1 Package Contents	23
1.2 How to Use this Guide	23
2.0 Installation	25
2.1 Product Description	25
2.1.1 Overview	25
2.1.2 Features of Layer 2 & Layer 3 Switches	25
2.2 Installing the Switch	31
2.2.1 Pre-Installation Considerations	31
2.2.2 Desktop or Shelf Mounting	31
2.2.3 Rack-Mounting	32
2.2.4 Power-On Self Test (POST)	32
3.0 Configuration	34
3.1 Management Access Overview	34
3.1.1 Administration Console	35
3.1.2 Direct Access	35
3.2 Web Management	36
3.3 SNMP-Based Network Management	36
3.4 Protocols	36
3.4.1 Virtual Terminal Protocols	36
3.4.2 SNMP Protocol	36
3.4.3 Management Architecture	37
4.0 Command Structure	38
4.1 Format	38
4.1.1 Command	38
4.1.2 Parameters	38
4.1.3 Values	39
4.1.4 Conventions	40
4.1.5 Annotations	40
5.0 Quick Start up	42
5.1 Quick Starting the Networking Device	42
5.2 System Info and System Setup	42
6.0 Mode-based Command Line Interface	47
6.1 Mode-based Topology	49

6.2 Mode-based Command Hierarchy	50
6.3 Flow of Operation	54
6.4 “No” Form of a Command	54
6.4.1 Support for “No” Form	54
7.0 Switching Commands	56
7.1 System Information and Statistics Commands	56
7.1.1 show arp switch	56
7.1.2 show eventlog	57
7.1.3 show hardware	57
7.1.4 show interface	57
7.1.5 show interface ethernet	58
7.1.6 show logging	64
7.1.7 show mac-addr-table	64
7.1.8 show running-config	65
7.1.9 show sysinfo	65
7.1.10 snmp-server	65
7.2 System Management Commands	66
7.2.1 telnet	66
7.2.2 transport input telnet	66
7.2.3 transport output telnet	66
7.2.4 session-limit	67
7.2.5 session-timeout	67
7.2.6 bridge aging-time	67
7.2.7 mtu	68
7.2.8 network javamode	68
7.2.9 network mac-address	69
7.2.10 network mac-type	69
7.2.11 network parms	69
7.2.12 network protocol	70
7.2.13 telnetcon maxsessions	70
7.2.14 telnetcon timeout	70
7.2.15 serial baudrate	71
7.2.16 serial timeout	71
7.2.17 set prompt	71
7.2.18 show telnet	72
7.2.19 show forwardingdb agetime	72
7.2.20 show network	72
7.2.21 show telnetcon	73
7.2.22 show serial	73

7.2.23 single_ip_mgmt enable (only for Layer 2 Series)	74
7.2.24 single_ip_mgmt groupid (only for Layer 2 Series)	74
7.2.25 single_ip_mgmt mastered (only for Layer 2 Series)	74
7.2.26 single_ip_mgmt network_parms (only for Layer 2 Series)	74
7.2.27 single_ip_mgmt switched (only for Layer 2 Series)	74
7.2.28 show single_ip_mgmt (only for Layer 2 Series)	75
7.3 SNMP Community Commands	76
7.3.1 show snmpcommunity	76
7.3.2 show snmptrap	76
7.3.3 show trapflags	77
7.3.4 snmp-server community	77
7.3.5 snmp-server community ipaddr	78
7.3.6 snmp-server community ipmask	78
7.3.7 snmp-server community mode	79
7.3.8 snmp-server community ro	79
7.3.9 snmp-server community rw	79
7.3.10 snmp-server enable traps	79
7.3.11 snmp-server enable traps bcaststorm	80
7.3.12 snmp-server enable traps linkmode	80
7.3.13 snmp-server enable traps multiusers	81
7.3.14 snmp-server enable traps stpmode	81
7.3.15 snmptrap	81
7.3.16 snmptrap ipaddr	82
7.3.17 snmptrap mode	82
7.3.18 snmp trap link-status	82
7.3.19 snmp trap link-status all	83
7.3.20 snmptrap snmpversion	83
7.4 Management VLAN Command	84
7.4.1 network mgmt_vlan	84
7.5 System Configuration Commands	85
7.5.1 addport	85
7.5.2 cablestatus	85
7.5.3 auto-negotiate	85
7.5.4 auto-negotiate all	85
7.5.5 deleteport (Interface Config)	86
7.5.6 deleteport (Global Config)	86
7.5.7 monitor session mode	86
7.5.8 monitor session 1 source interface	87
7.5.9 shutdown	87

7.5.10 shutdown all	88
7.5.11 speed	88
7.5.12 speed all	88
7.5.13 switchport protected all	89
7.5.14 switchport protected	89
7.5.15 storm-control broadcast	89
7.5.16 storm-control flowcontrol	90
7.5.17 storm-control action shutdown	90
7.5.18 storm-control action trap	91
7.5.19 storm-control action trap-shotdown	91
7.5.20 storm-control mode broadcast	91
7.5.21 storm-control mode multicast	91
7.5.22 storm-control mode unicast	91
7.5.23 storm-control level	92
7.5.24 storm-control recovery-time	92
7.5.25 show mac-address-table multicast	92
7.5.26 show mac-address-table static	93
7.5.27 show mac-address-table stats	93
7.5.28 show monitor session	93
7.5.29 show port	94
7.5.30 show port protocol	95
7.5.31 show storm-control	95
7.5.32 show interface protected	95
7.6 Virtual LAN (VLAN) Commands	96
7.6.1 vlanset	96
7.6.2 vlan	96
7.6.3 vlan acceptframe	96
7.6.4 vlan ingressfilter	97
7.6.5 vlan makestatic	97
7.6.6 vlan name	98
7.6.7 vlan participation	98
7.6.8 vlan participation all	98
7.6.9 vlan port acceptframe all	99
7.6.10 vlan port ingressfilter all	99
7.6.11 vlan port pvid all	100
7.6.12 vlan port tagging all	100
7.6.13 vlan protocol group	100
7.6.14 vlan protocol group add protocol	100
7.6.15 vlan protocol group remove	101
7.6.16 protocol group	101

7.6.17 protocol vlan group	102
7.6.18 protocol vlan group all	102
7.6.19 vlan pvid	102
7.6.20 vlan tagging	103
7.6.21 show vlan	103
7.6.22 show vlan brief	104
7.6.23 show vlan port	105
7.6.24 vtrunk set	105
7.6.25 vtrunk clear	105
7.7 System Utility Commands	107
7.7.1 traceroute	107
7.7.2 clear config	107
7.7.3 clear counters	107
7.7.4 clear igmpsnooping	107
7.7.5 clear pass	108
7.7.6 enable passwd	108
7.7.7 clear port-channel	108
7.7.8 clear traplog	108
7.7.9 clear vlan	108
7.7.10 logout	108
7.7.11 ping	109
7.7.12 reload	109
7.7.13 copy	109
7.7.14 autosave	110
7.7.15 cpu-port-security	110
7.7.16 cpu-port-security max-entries	111
7.7.17 cpu-port-security allow	111
7.7.18 cpu-port-security allow	111
7.7.19 cpu-port-security deny	111
7.7.20 cpu-port-security deny	112
7.7.21 show cpu statistics	112
7.7.22 show cpu-port-security	112
7.8 Pre-login Banner Command	114
7.8.1 copy	114
7.9 CLI Command Logging Command	115
7.9.1 logging cli-command	115
7.10 Configuration Scripting Commands	116
7.10.1 script apply	116
7.10.2 script delete	116

7.10.3 script list	116
7.10.4 script show	117
7.10.5 script validate	117
7.11 System Log (Syslog) Commands	118
7.11.1 logging buffered	118
7.11.2 logging buffered wrap	118
7.11.3 logging console	119
7.11.4 logging persistent	119
7.11.5 logging host	119
7.11.6 logging syslog	120
7.11.7 logging syslog port	120
7.11.8 show logging	120
7.11.9 show logging persistent	121
7.11.10 show logging buffered	121
7.11.11 show logging hosts	122
7.11.12 show logging traplogs	122
7.12 User Account Commands	123
7.12.1 disconnect	123
7.12.2 show loginsession	123
7.12.3 show users	123
7.12.4 users name	124
7.12.5 users passwd	124
7.12.6 users snmpv3 accessmode	125
7.12.7 users snmpv3 authentication	125
7.12.8 users snmpv3 encryption	126
7.13 Simple Network Time Protocol (SNTP) Commands	127
7.13.1 sntp broadcast client poll-interval	127
7.13.2 sntp client mode	127
7.13.3 sntp client port	128
7.13.4 sntp unicast client poll-interval	128
7.13.5 sntp unicast client poll-timeout	128
7.13.6 sntp unicast client poll-retry	129
7.13.7 sntp server	129
7.13.8 show sntp	129
7.13.9 show sntp client	130
7.13.10 show sntp server	130
7.14 DHCP Server Commands	132
7.14.1 client-identifier	132
7.14.2 client-name	132

7.14.3 default-router	133
7.14.4 dns-server	133
7.14.5 hardware-address	133
7.14.6 host	134
7.14.7 ip dhcp excluded-address	134
7.14.8 ip dhcp ping packets	135
7.14.9 ip dhcp pool	135
7.14.10 lease	136
7.14.11 network	136
7.14.12 service dhcp	136
7.14.13 bootfile	137
7.14.14 domain-name	137
7.14.15 ip dhcp bootp automatic	138
7.14.16 ip dhcp conflict logging	138
7.14.17 netbios-name-server	138
7.14.18 netbios-node-type	139
7.14.19 next-server	139
7.14.20 option	140
7.14.21 show ip dhcp binding	140
7.14.22 show ip dhcp global configuration	140
7.14.23 show ip dhcp pool configuration	141
7.14.24 show ip dhcp server statistics	141
7.14.25 show ip dhcp conflict	142
7.14.26 clear ip dhcp binding	143
7.14.27 clear ip dhcp server statistics	143
7.14.28 clear ip dhcp conflict	143
7.15 Double VLAN Commands	144
7.15.1 dvlan-tunnel customer-id	144
7.15.2 dvlan-tunnel etherType	144
7.15.3 mode dot1q-tunnel	145
7.15.4 mode dvlan-tunnel	145
7.15.5 show dot1q-tunnel	145
7.15.6 show dot1q-tunnel interface	146
7.15.7 show dvlan-tunnel	146
7.15.8 show dvlan-tunnel interface	146
7.16 Provisioning (IEEE 802.1p) Commands	147
7.16.1 classofservice dot1pmapping	147
7.16.2 show classofservice dot1pmapping	147
7.16.3 vlan port priority all	147

7.16.4	vlan priority	147
7.17	GARP Commands	149
7.17.1	set garp timer join	149
7.17.2	set garp timer leave	149
7.17.3	set garp timer leaveall	150
7.17.4	show garp	150
7.18	GARP VLAN Registration Protocol (GVRP) Commands	151
7.18.1	set gvrp	151
7.18.2	set gvrp adminmode	151
7.18.3	set gvrp interfacemode	151
7.18.4	show gvrp configuration	152
7.19	GARP Multicast Registration Protocol (GMRP) Commands	153
7.19.1	set gmrp adminmode	153
7.19.2	set gmrp interfacemode	153
7.19.3	show gmrp configuration	154
7.19.4	show mac-address-table gmrp	154
7.20	IGMP Snooping Commands	155
7.20.1	set igmp	155
7.20.2	set igmp fast-leave	156
7.20.3	show igmpsnooping	156
7.20.4	show igmpsnooping mrouter interface	157
7.20.5	show mac-address-table igmpsnooping	157
7.21	Link Aggregation (LAG)/Port-Channel (802.3AD) Commands	158
7.21.1	port-channel staticcapability	158
7.21.2	port lacpmode all	158
7.21.3	port-channel	159
7.21.4	port-channel adminmode all	159
7.21.5	port-channel linktrap	159
7.21.6	port-channel name	160
7.21.7	show port-channel brief	160
7.21.8	show port-channel	161
7.21.9	show port-channel summary	161
7.22	Spanning Tree (STP) Commands	163
7.22.1	spanning-tree	163
7.22.2	spanning-tree	163

7.22.3 spanning-tree bpdumigrationcheck	164
7.22.4 spanning-tree configuration name	164
7.22.5 spanning-tree configuration revision	164
7.22.6 spanning-tree edgeport	165
7.22.7 spanning-tree forceversion	165
7.22.8 spanning-tree forward-time	166
7.22.9 spanning-tree hello-time	166
7.22.10 spanning-tree max-age	166
7.22.11 spanning-tree max-hops	167
7.22.12 spanning-tree mst instance	167
7.22.13 spanning-tree mst priority	168
7.22.14 spanning-tree mst vlan	168
7.22.15 spanning-tree port mode	169
7.22.16 spanning-tree port mode all	169
7.22.17 show spanning-tree	169
7.22.18 show spanning-tree summary	171
7.22.19 show spanning-tree interface	171
7.22.20 show spanning-tree mst port detailed	172
7.22.21 show spanning-tree mst port summary	173
7.22.22 show spanning-tree mst summary	174
7.22.23 show spanning-tree vlan	174
7.23 Bootp/DHCP Relay Commands	175
7.23.1 bootpdhcprelay cidoptmode	175
7.23.2 bootpdhcprelay enable	175
7.23.3 bootpdhcprelay maxhopcount	175
7.23.4 bootpdhcprelay minwaittime	176
7.23.5 bootpdhcprelay serverip	176
7.23.6 show bootpdhcprelay	177
7.24 Loopback Detection Commands	178
7.24.1 loopback-detection enable all	178
7.24.2 loopback-detection enable	178
7.24.3 loopback-detection interval <5-60>	178
7.24.4 show loopback-detection	179
8.0 Security Commands	180
8.1 Port Security Commands	180
8.1.1 port-security	180
8.1.2 port-security deny	180
8.1.3 port-security allow	181
8.1.4 port-security cpu-multicast-rate-limit	181

8.1.5	port-security max-dynamic	181
8.1.6	port-security max-static	181
8.1.7	port-security max-static allow	182
8.1.8	port-security max-static deny	182
8.1.9	port-security mac-address	182
8.1.10	port-security mac-address move	183
8.1.11	snmp-server enable traps violation	183
8.1.12	show port-security	183
8.1.13	show port-security <interface all>	183
8.1.14	show port-security allow	184
8.1.15	show port-security deny	184
8.1.16	show port-security dynamic	184
8.1.17	show port-security static	185
8.1.18	show port-security static allow	185
8.1.19	show port-security static deny	185
8.1.20	show port-security violation	185
8.1.21	show port-security cpu-multicast-rate-limit	186
8.2 Port Based Network Access Control (IEEE 802.1X)		
Commands		187
8.2.1	authentication login	187
8.2.2	clear dot1x statistics	187
8.2.3	clear radius statistics	188
8.2.4	dot1x defaultlogin	188
8.2.5	dot1x initialize	188
8.2.6	dot1x login	188
8.2.7	dot1x max-req	188
8.2.8	dot1x port-control	189
8.2.9	dot1x port-control All	189
8.2.10	dot1x re-authenticate	190
8.2.11	dot1x re-authentication	190
8.2.12	dot1x system-auth-control	190
8.2.13	dot1x timeout	190
8.2.14	dot1x user	191
8.2.15	dot1x port-method macbased	191
8.2.16	dot1x port-method portbased	192
8.2.17	show radius accounting	192
8.2.18	show authentication	193
8.2.19	show authentication users	193
8.2.20	show dot1x	194

8.2.21 show dot1x users	195
8.2.22 show users authentication	196
8.2.23 users defaultlogin	196
8.2.24 users login	196
8.3 Remote Authentication Dial In User Service (RADIUS)	
Commands	197
8.3.1 radius accounting mode	197
8.3.2 radius server host	197
8.3.3 radius server key	198
8.3.4 radius server msgauth	198
8.3.5 radius server primary	198
8.3.6 radius server retransmit	198
8.3.7 radius server timeout	199
8.3.8 tacacs-server host	199
8.3.9 tacacs-server key	200
8.3.10 tacacs-server timeout	200
8.3.11 show radius	200
8.3.12 show radius statistics	201
8.3.13 show tacacs-server	202
8.4 Secure Shell (SSH) Commands	203
8.4.1 ip ssh	203
8.4.2 ip ssh protocol	203
8.4.3 sshcon maxsessions	203
8.4.4 sshcon timeout	204
8.4.5 show ip ssh	204
8.5 Hypertext Transfer Protocol (HTTP) Commands	205
8.5.1 ip http secure-port	205
8.5.2 ip http secure-protocol	205
8.5.3 ip http secure-server	205
8.5.4 ip http server	206
8.5.5 show ip http	206
9.0 Quality of Service (QoS) Commands	207
9.1 MAC Access Control List (ACL) Commands	207
9.1.1 mac access-list extended	207
9.1.2 mac access-list extended rename	208
9.1.3 {deny permit}	208
9.1.4 mac access-group	209
9.1.5 show mac access-lists	210
9.1.6 show mac acl-counters	210

9.2 IP Access Control List (ACL) Commands	211
9.2.1 access-list	211
9.2.2 ip access-group	212
9.2.3 show ip access-lists	212
9.2.4 show access-list interface	213
9.2.5 show ip acl-counters (only for Layer 2 Series)	213
9.3 Differentiated Services (DiffServ) Commands	214
9.3.1 diffserv	215
9.4 Class Commands	216
9.4.1 class-map	216
9.4.2 class-map rename	217
9.4.3 match ethertype	217
9.4.4 match any	217
9.4.5 match class-map	218
9.4.6 match cos	218
9.4.7 match destination-address mac	219
9.4.8 match dstip	219
9.4.9 match dstl4port	219
9.4.10 match ip dscp	220
9.4.11 match ip precedence	220
9.4.12 match ip tos	220
9.4.13 match protocol	221
9.4.14 match source-address mac	221
9.4.15 match srcip	222
9.4.16 match srcl4port	222
9.4.17 match vlan	222
9.5 Policy Commands	224
9.5.1 assign-queue	224
9.5.2 drop	224
9.5.3 redirect	224
9.5.4 conform-color	225
9.5.5 class	225
9.5.6 mark cos	225
9.5.7 mark ip-dscp	226
9.5.8 mark ip-precedence	226
9.5.9 police-simple	226
9.5.10 policy-map	227
9.5.11 policy-map rename	227
9.6 Service Commands	228

9.6.1 service-policy	228
9.7 Show Commands	229
9.7.1 show class-map	229
9.7.2 show diffserv	230
9.7.3 show policy-map	230
9.7.4 show diffserv service	232
9.7.5 show diffserv service brief	232
9.7.6 show policy-map interface	233
9.7.7 show service-policy	234
9.8 Class of Service (CoS) Commands	235
9.8.1 classofservice dot1p-mapping	235
9.8.2 classofservice ip-dscp-mapping	235
9.8.3 classofservice ip-precedence-mapping	235
9.8.4 classofservice trust	235
9.8.5 cos-queue wfq min-bandwidth	236
9.8.6 cos-queue wrr wrr-weights	236
9.8.7 cos-queue strict	236
9.8.8 show classofservice dot1p-mapping	237
9.8.9 show classofservice ip-dscp-mapping	237
9.8.10 show classofservice ip-precedence-mapping	237
9.8.11 show classofservice trust	238
9.8.12 show interfaces cos-queue	238
9.9 Rate-Limiting Commands	240
9.9.1 rate-limiting	240
9.9.2 show rate-limiting	240
10.0 Stacking Commands	241
10.1 Dedicated-port Stacking	241
10.1.1 show supported switchtype	241
10.1.2 member	242
10.1.3 switch priority	242
10.1.4 switch renumber	242
10.1.5 movemanagement	242
10.1.6 archive copy-sw	243
10.1.7 archive download-sw	243
10.1.8 slot	243
10.1.9 set slot disable	244
10.1.10 set slot power	244
10.1.11 show slot	245
10.1.12 show supported cardtype	246

10.1.13 reload	246
10.2 Front Panel Stacking	247
10.2.1 stack-port	247
10.2.2 qos-mode	247
11.0 Routing Commands	248
11.1 Address Resolution Protocol (ARP) Commands	248
11.1.1 arp	248
11.1.2 ip proxy-arp	248
11.1.3 arp purge	249
11.1.4 arp dynamicrenew	249
11.1.5 arp resptime	249
11.1.6 arp retries	250
11.1.7 arp timeout	250
11.1.8 clear arp-cache	250
11.1.9 show arp	251
11.1.10 show arp brief	251
11.2 IP Routing	253
11.2.1 routing	253
11.2.2 ip routing	253
11.2.3 ip address	253
11.2.4 ip route	254
11.2.5 ip route default	254
11.2.6 ip route distance	255
11.2.7 ip forwarding	255
11.2.8 ip netdirbcast	255
11.2.9 ip mtu	256
11.2.10 show ip brief	256
11.2.11 show ip interface	257
11.2.12 show ip interface brief	257
11.2.13 show ip route	258
11.2.14 show ip route bestroutes	258
11.2.15 show ip route entry	258
11.2.16 show ip route preferences	259
11.2.17 show ip stats	259
11.2.18 encapsulation	259
11.3 Router Discovery Protocol Commands	260
11.3.1 ip irdp	260
11.3.2 ip irdp address	260
11.3.3 ip irdp holdtime	260

11.3.4 ip irdp maxadvertinterval	261
11.3.5 ip irdp minadvertinterval	261
11.3.6 ip irdp preference	261
11.3.7 show ip irdp	262
11.4 Virtual LAN Routing Commands	263
11.4.1 vlan routing	263
11.4.2 show ip vlan	263
11.5 Virtual Router Redundancy Protocol (VRRP) Commands	264
11.5.1 ip vrrp	264
11.5.2 ip vrrp	264
11.5.3 ip vrrp mode	265
11.5.4 ip vrrp ip	265
11.5.5 ip vrrp authentication	265
11.5.6 ip vrrp preempt	266
11.5.7 ip vrrp priority	266
11.5.8 ip vrrp timers advertise	267
11.5.9 show ip vrrp interface stats	267
11.5.10 show ip vrrp	268
11.5.11 show ip vrrp interface	268
11.5.12 show ip vrrp interface brief	268
11.6 Open Shortest Path First (OSPF) Commands	270
11.6.1 enable (OSPF)	270
11.6.2 ip ospf	270
11.6.3 1583compatibility	270
11.6.4 area authentication	271
11.6.5 area default-cost	271
11.6.6 area nssa	271
11.6.7 area nssa default-info-originate	272
11.6.8 area nssa no-redistribute (OSPF)	272
11.6.9 area nssa no-summary (OSPF)	272
11.6.10 area nssa translator-role (OSPF)	272
11.6.11 area nssa translator-stab-intv	273
11.6.12 area range	273
11.6.13 area stub	273
11.6.14 area stub summarylsa	274
11.6.15 area virtual-link	274
11.6.16 area virtual-link authentication	274
11.6.17 area virtual-link dead-interval	275

11.6.18 area virtual-link hello-interval	275
11.6.19 area virtual-link retransmit-interval	276
11.6.20 area virtual-link transmit-delay	276
11.6.21 default-information originate (OSPF)	277
11.6.22 default-metric (OSPF)	277
11.6.23 distance ospf	277
11.6.24 distribute-list out	278
11.6.25 exit-overflow-interval	278
11.6.26 external-lsdb-limit	278
11.6.27 ip ospf areaid	279
11.6.28 ip ospf authentication	279
11.6.29 ip ospf cost	279
11.6.30 ip ospf dead-interval	280
11.6.31 ip ospf hello-interval	280
11.6.32 ip ospf priority	281
11.6.33 ip ospf retransmit-interval	281
11.6.34 ip ospf transmit-delay	282
11.6.35 ip ospf mtu-ignore	282
11.6.36 router-id	282
11.6.37 redistribute	283
11.6.38 maximum-paths	283
11.6.39 show ip ospf	283
11.6.40 show ip ospf area	285
11.6.41 show ip ospf database	285
11.6.42 show ip ospf interface	286
11.6.43 show ip ospf interface brief	287
11.6.44 show ip ospf interface stats	288
11.6.45 show ip ospf neighbor	288
11.6.46 show ip ospf neighbor brief	289
11.6.47 show ip ospf range	290
11.6.48 show ip ospf stub table	290
11.6.49 show ip ospf virtual-link	291
11.6.50 show ip ospf virtual-link brief	291
11.6.51 trapflags	291
11.7 Routing Information Protocol (RIP) Commands	293
11.7.1 enable (RIP)	293
11.7.2 ip rip	293
11.7.3 auto-summary	294
11.7.4 default-information originate (RIP)	294
11.7.5 default-metric (RIP)	294

11.7.6 distance rip	294
11.7.7 distribute-list out	295
11.7.8 ip rip authentication	295
11.7.9 ip rip receive version	296
11.7.10 ip rip send version	296
11.7.11 hostroutesaccept	297
11.7.12 split-horizon	297
11.7.13 redistribute	297
11.7.14 show ip rip	298
11.7.15 show ip rip interface brief	298
12.0 Border Gateway Protocol (BGP) Commands	300
12.1 BGP Commands	300
12.1.1 aggregate-address	300
12.1.2 bgp addrfamily create	300
12.1.3 bgp autorestart	301
12.1.4 bgp calcmmedmode	301
12.1.5 bgp cluster-id	301
12.1.6 bgp community	302
12.1.7 bgp confederation identifier	302
12.1.8 bgp default local-preference	303
12.1.9 bgp flapdamping dampfactor	303
12.1.10 bgp flapdamping flapmaxtime	303
12.1.11 bgp flapdamping mode	304
12.1.12 bgp flapdamping penaltyinc	304
12.1.13 bgp flapdamping reuselimit	304
12.1.14 bgp flapdamping reusemaxsize	305
12.1.15 bgp flapdamping suppresslimit	305
12.1.16 bgp flapdamping timerresolution	306
12.1.17 bgp interval minasorigin	306
12.1.18 bgp interval minrouteadvint	306
12.1.19 bgp localmed	307
12.1.20 bgp optionalcap	307
12.1.21 bgp origin	307
12.1.22 bgp policy	308
12.1.23 bgp policy action addint	308
12.1.24 bgp policy action addip	309
12.1.25 bgp policy action remove	310
12.1.26 bgp policy range address	310
12.1.27 bgp policy range between	310

12.1.28	bgp policy range equal	310
12.1.29	bgp policy range greaterthan	311
12.1.30	bgp policy range lessthan	311
12.1.31	bgp policy range match	311
12.1.32	bgp policy range remove	311
12.1.33	bgp propmedmode	311
12.1.34	bgp router-id	312
12.1.35	bgp snpa	312
12.1.36	bgp suppressmode	313
12.1.37	clear bgp	313
12.1.38	default-information originate (BGP)	313
12.1.39	default-metric (BGP)	313
12.1.40	distance bgp	314
12.1.41	distribute-list out	314
12.1.42	enable (BGP)	314
12.1.43	neighbor <peeripaddr> addrfamily	315
12.1.44	neighbor <peeripaddr> authentication none	315
12.1.45	neighbor <peeripaddr> authentication simple	315
12.1.46	neighbor <peeripaddr> confedmember	316
12.1.47	neighbor <peeripaddr> connretry	316
12.1.48	neighbor <peeripaddr> msgsendlimit	317
12.1.49	neighbor <peeripaddr> next-hop-self	317
12.1.50	neighbor <peeripaddr> optionalcap	317
12.1.51	neighbor <peeripaddr> remote-as	318
12.1.52	neighbor <peeripaddr> maximum-prefix	318
12.1.53	neighbor <peeripaddr> route-reflector-client	319
12.1.54	neighbor <peeripaddr> shutdown	319
12.1.55	neighbor <peeripaddr> timers <keepalive> <holdtime>	320
12.1.56	neighbor <peeripaddr> txdelayint	320
12.1.57	network	320
12.1.58	redistribute	321
12.1.59	route-aggregation	321
12.1.60	route-reflect	322
12.1.61	trapflags	322
12.1.62	show ip bgp	322
12.1.63	show ip bgp addrfamilyinfo	323
12.1.64	show ip bgp aggregate-address	323
12.1.65	show ip bgp brief	323
12.1.66	show ip bgp damping	325
12.1.67	show ip bgp local	326

12.1.68	show ip bgp mplslabels	326
12.1.69	show ip bgp neighbors	327
12.1.70	show ip bgp neighbors addrfamilyinfo	328
12.1.71	show ip bgp neighbors stats	328
12.1.72	show ip bgp nlrlist	328
12.1.73	show ip bgp pathattrtable	329
12.1.74	show ip bgp peer-list	330
12.1.75	show ip bgp policy brief	330
12.1.76	show ip bgp policy detailed	330
12.1.77	show ip bgp snpalist	331
12.1.78	show ip bgp trapflags	331
13.0	IP Multicast Commands	332
13.1	Multicast Commands	332
13.1.1	ip mcast boundary	332
13.1.2	ip multicast	332
13.1.3	ip multicast staticroute	333
13.1.4	ip multicast ttl-threshold	333
13.1.5	mrinfo	333
13.1.6	mstat	334
13.1.7	mtrace	334
13.1.8	show ip mcast	334
13.1.9	show ip mcast boundary	335
13.1.10	show ip mcast interface	335
13.1.11	show ip mcast mroute	336
13.1.12	show ip mcast mroute group	336
13.1.13	show ip mcast mroute source	337
13.1.14	show ip mcast mroute static	337
13.1.15	show mrinfo	338
13.1.16	show mstat	338
13.1.17	show mtrace	338
13.2	Distance Vector Multicast Routing Protocol (DVMRP) Commands	340
13.2.1	ip dvmrp	340
13.2.2	ip dvmrp metric	340
13.2.3	ip dvmrp trapflags	340
13.2.4	show ip dvmrp	341
13.2.5	show ip dvmrp interface	341
13.2.6	show ip dvmrp neighbor	342
13.2.7	show ip dvmrp nexthop	342

13.2.8 show ip dvmrp prune	343
13.2.9 show ip dvmrp route	343
13.3 Internet Group Management Protocol (IGMP)	
Commands	344
13.3.1 ip igmp	344
13.3.2 ip igmp version	344
13.3.3 set igmp mcrtrexpiretime	344
13.3.4 ip igmp last-member-query-count	345
13.3.5 ip igmp last-member-query-interval	345
13.3.6 ip igmp query-interval	346
13.3.7 ip igmp query-max-response-time	346
13.3.8 ip igmp robustness	346
13.3.9 ip igmp startup-query-count	347
13.3.10 ip igmp startup-query-interval	347
13.3.11 set igmp groupmembershipinterval	348
13.3.12 set igmp maxresponse	348
13.3.13 set igmp mrouter interface	348
13.3.14 set igmp mrouter	349
13.3.15 show ip igmp	349
13.3.16 show ip igmp groups	350
13.3.17 show ip igmp interface	351
13.3.18 show ip igmp interface membership	351
13.3.19 show ip igmp interface stats	352
13.4 Protocol Independent Multicast - Dense Mode (PIM-DM) Commands	353
13.4.1 ip pimdm	353
13.4.2 ip pimdm mode	353
13.4.3 ip pimdm query-interval	354
13.4.4 show ip pimdm	354
13.4.5 show ip pimdm interface	354
13.4.6 show ip pimdm interface stats	355
13.4.7 show ip pimdm neighbor	355
13.4.8 show ip pimdm componenttable	355
13.5 Protocol Independent Multicast - Sparse Mode(PIM-SM) Commands	356
13.5.1 ip pimsm cbsrpreference	356
13.5.2 ip pimsm cbsrhashmasklength	356
13.5.3 ip pimsm crppreference	357
13.5.4 ip pimsm message-interval	357

13.5.5 ip pimsm	358
13.5.6 ip pimsm mode	358
13.5.7 ip pimsm query-interval	358
13.5.8 ip pimsm spt-threshold	359
13.5.9 ip pim-trapflags	359
13.5.10 ip pimsm staticrp	360
13.5.11 ip pimsm register-rate-limit	360
13.5.12 show ip pimsm rphash	360
13.5.13 show ip pimsm staticrp	360
13.5.14 show ip pimsm	361
13.5.15 show ip pimsm componenttable	361
13.5.16 show ip pimsm interface	362
13.5.17 show ip pimsm interface stats	362
13.5.18 show ip pimsm neighbor	363
13.5.19 show ip pimsm rp	363
13.5.20 show ip pimsm rphash	363
14.0 Using the Web Interface	365
14.1 Configuring for Web Access	365
14.1.1 Web Page Layout	365
14.1.2 Starting the Web Interface	366
14.1.3 Command Buttons	366
Glossary	367

The information in this guide may change without notice. The manufacturer assumes no responsibility for any errors, which may appear in this guide.

Ethernet is a trademark of XEROX Corporation. Microsoft, Windows and Windows logo are trademarks of Microsoft Corporation.

Copyright 2006. All right reserved. No Part of the contents of this guide maybe transmitted or reproduced in any form or by any means without the written permission of the manufacturer. Printed in Taiwan.

The revision date for this guide is **Mar. 16th, 2006**
Version 1.00

FCC Statement

This product has been tested and found to comply with the limits for a Class B digital device pursuant to Part 15 of FCC Rules. These limits are designed to provide reasonable protection against such interference when operating in a commercial environment. This equipment generates, uses and can radiate radio frequency energy, and if not installed and used according to the instructions, may cause harmful interference to radio communications.

Operation of this equipment in a residential area is likely to cause interference in which case the user, at his or her own expense will be required to take whatever measures may be required to correct the interference.

CE Mark Warning

This is a Class B product. In a domestic environment, this product may cause radio interference in which case the user may be required to take adequate measures.

1.0 Introduction

This manual will apply to the following name of Gigabit Ethernet Management Switch:

Throughout this guide, the Layer2 SNMP Managed Switch will be referred to as the **Managed Switch** or the **Switch**.

Designed as the SNMP managed switch, these series of Switches provide dominant ability of management and multiple ports. Strictly adhering to the network standards, these SNMP Managed Switches can easily fit in your network configuration and can be executed for its management functions through the console and the web browser.

1.1 Package Contents

The package contains the following:

- ◆ A Managed Switch (According the Model)
- ◆ One Power Cord
- ◆ Mounting Brackets
- ◆ One Serial/Console Cable
- ◆ CD - User Guide

If any of the listed items is missing or damaged, please contact the place of purchase.

1.2 How to Use this Guide

This user guide is structured as follows:

- Chapter 2, *Product Description* explains the features of the switch and the front/rear panel indicates
- Chapter 3, *Installing the Switch* explains how to physically install it.
- Chapter 4, *Command Structure* explains the command's general format.
- Chapter 5, *Quick Start up* details procedures to quickly become acquainted with the switch.
- Chapter 6, *Mode-based Command Line Interface (CLI)* groups all the commands in appropriate modes according to the nature of the commands.
- Chapter 7-Chapter 13 lists the format and usage of all commands.
- Chapter 14, *Using the Web Interface* introduces the web screen structure.

2.0 Installation

This Chapter describes the function of the managed switch components and shows how to install it on the desktop or shelf. Basic knowledge of networking is assumed. Read this chapter completely before continuing.

2.1 Product Description

2.1.1 Overview

The SNMP Managed Switches are with powerful network management function and flexible connectivity combination. Diversified management access windows and user-friendly interface, Console, Telnet, and Web, facilitate administrators' job, reducing the management effort to the minimum.

2.1.2 Features of Layer 2 & Layer 3 Switches

- *Half/full duplex mode for ports in 10/100M speed and full duplex mode in 1000Mbps speed*
- *Non-blocking switching architecture.*
- *Flow control mechanism to ensure zero packet loss. Uses IEEE802.3x for full duplex operation and collision-like backpressure for half duplex operation.*
- *Store-and-forward forwarding scheme.*
- *Port-mirroring function / Multiple Port-mirroring function*
- *Link Aggregation function (2, 3 or 4 ports per link).*
- *Up to 8 trunk group*
- *802.3ad LACP*
- *Broadcast Storm Control*
- *Multicast-filtering. (IGMP snooping)*
- *GVRP protocol for VLAN management.*
- *4092 802.1q Tagged VLAN*
- *Protected port*
- *Rate limit control for both Egress and Ingress (64 Kbps granularity)*
- *802.1x and Radius 802.1x*
- *Layer-4 Access Control List*
- *Spanning Tree protocol (IEEE 802.1D)*
- *802.1w Fast STP*
- *802.1s Multi-STP*
- *Up to 8 units Stacking supported(for Layer 2 switch only)*
- *Class of Service(IEEE 802.1P/802.1Q)*
- *8-level priority for switching*
- *CoS-based Head Of Line (HOL) blocking prevention*
- *Differentiated Service (DiffServ)*
- *Comand line interface from the console port using a VT-100 terminal.*
- *RMON (group 1,2,3 and 9)*
- *MIB II, Ethernet MIB, Bridge MIB and GR-5500 private MIB*
- *WEB-based management*

- **TELNET console interface**
- **BOOTP for IP address assignment**
- **Firmware upgrade by TFTP file transfer protocol through Ethernet network.**
- **Redundant power supply(optional)**
- **(Layer 3 switch series only)**
 - **Built-in DHCP Server**
 - **DHCP Relay Agent**
 - **L3 IP packets wired-speed Forwarding.**
 - **RIP v1/v2, OSPF v2 for backward compatible with traditional router**
 - **4K IPv4, address, 16K Routing table**
 - **Layer 3 wired-speed routing among all ports(IPV4)**
 - **Fully compatible with existing routing protocol: RIP V1/V2, OSPF V2, PIM, DVMRP.**
- **1 Male DB9 RS-232C console interface configured as DTE for operation, diagnostics, status, and configuration information.**
- **IEEE 802.3ac frame extension for VLAN tagging.**

2.2 Installing the Switch

The switch is designed for office use, where it can be free standing, desktop-mounted, or mounted in most standard 19-inch equipment racks. If you prefer, you can rack-mount the switch in a wiring closet or equipment room using two mounting brackets and six screws.

When choosing a location for the switch, observe the following guidelines:

- Make sure the switch is accessible and that the cables can be connected easily.
- Keep cabling away from sources of electrical noise such as radios, transmitters, and broadband amplifiers as well as power lines and fluorescent lighting fixtures.
- Prevent water or moisture from entering the switch case.
- Make sure there are no obstructions to restrict airflow around the switch. We recommend that you provide a minimum of 50 millimeter (2-inch) clearance.
- Do not place liquids or other objects on top of the switch.
- If the switches are freestanding, do not stack more than four switches on top of one another.

2.2.1 Pre-Installation Considerations

Fast Ethernet Topology Considerations

If you will be using the switch for Fast Ethernet (100 Mbps) operation, observe the following guidelines:

- The maximum unshielded twisted-pair (UTP) cable length is 100 meters (328 feet) over Category 5 cable.
- Single-repeater topologies permit a total network span of 325 meters (1066 feet).

Full-Duplex Considerations

The switch provides full-duplex support for its Fast Ethernet ports. Full-duplex operation allows frames to be sent and received simultaneously, doubling a link's potential data throughput. If you will be using the switch in full-duplex mode, the maximum UTP cable length is 100 meters (328 feet) over Category 5 cable.

2.2.2 Desktop or Shelf Mounting

To install the switch on a desktop or shelf, simply complete the following steps:

Step 1 Place the switch on a desktop or shelf near an AC power source.

Step 2 Keep enough ventilation space between the switch and the surrounding objects.

Step 3 Connect the switch to network devices.

A. Connect one end of a standard network cable to the 10/100 RJ-45 ports on the front of the switch.

B. Connect the other end of the cable to the network devices such as printer servers, workstations or routers.

Note: It is strongly recommended to use the UTP Category 5 network cabling with RJ-45 tips for the network connection.

Step 4 Supply power to the switch.

- A.** Connect one end of the power cable to the switch.
- B.** Connect the power cube end of the power cable to a standard wall outlet.

When the switch receives power, the Power LED should remain solid Green.

2.2.3 Rack-Mounting

The following procedure describes how to install the switch in a standard 19-inch rack.

- Disconnect all cables from the switch.
- Remove all adhesive pads from the bottom of the switch.

Step 1 Place the switch right side up on a hard flat surface, with the front panel facing you.

Step 2 Locate a mounting bracket over the mounting holes on one side of the switch

Step 3 Insert three screws and use a screwdriver to secure.

Step 4 Repeat the two previous steps for the other side of the switch.

Step 5 Insert the switch into the 19-inch rack and secure with suitable screws. Make sure the ventilation holes on the switch are not obstructed.

Step 6 Connect the network cable and supply power to the switch.

Figure 1 Locating a Mounting Bracket

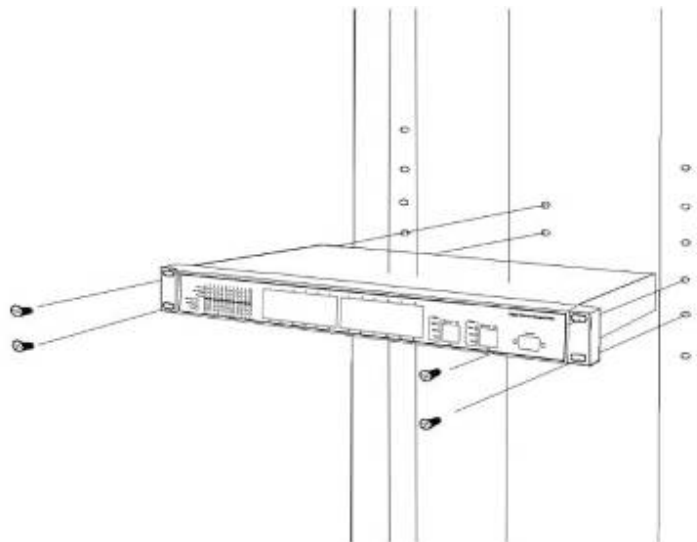

2.2.4 Power-On Self Test (POST)

When you power-on the switch, it performs its Power-On Self Test (POST). During the POST, the switch CPU:

- Performs a series of diagnostic procedures to make sure the basic system is functioning

with integrity.

- Decompresses the main switching software run-time image from the flash ROM into DRAM area.
- Begins executing the main switching software.

3.0 Configuration

This chapter explains the methods that you can use to configure management access to the switch. It describes the types of management applications and the communication and management protocols that deliver data between your management device (work-station or personal computer) and the system. It also contains information about port connection options.

This chapter covers the following topics:

- Management Access Overview
- Key Concepts
- Key Guidelines for Implementation
- Administration Console Access
- Web Management Access
- SNMP Access
- Standards, Protocols, and Related Reading

3.1 Management Access Overview

The switch gives you the flexibility to access and manage the switch using any or all of the following methods:

- An administration console
- Web browser interface
- An external SNMP-based network management application

The administration console and Web browser interface support are embedded in the switch software and are available for immediate use. Each of these management methods has their own advantages. Table 4 compares the three management methods.

Table 1 Comparisons of Three Management Methods

Management Method	Advantages	Disadvantages
Administration console	<ul style="list-style-type: none">• No IP address or subnet needed• Text-based• Telnet functionality and HyperTerminal built into Windows 95/98/NT/2000/ME/XP operating systems• Secure	<ul style="list-style-type: none">• Must be near switch or use dial-up connection• Not convenient for remote users• Modem connection may prove to be unreliable or slow
Web browser	<ul style="list-style-type: none">• Ideal for configuring the switch remotely• Compatible with all	<ul style="list-style-type: none">• Security can be compromised (hackers need only know the IP address and subnet mask)

	popular browsers ● Can be accessed from any location ● Most visually appealing	● May encounter lag times on poor connections
SNMP Agent	● Communicates with switch functions at the MIB level ● Based on open standards	● Requires SNMP manager software ● Least visually appealing of all three methods ● Some settings require calculations ● Security can be compromised (hackers need only know the community name)

3.1.1 Administration Console

The administration console is an internal, character-oriented, and command line user interface for performing system administration such as displaying statistics or changing option settings. Using this method, you can view the administration console from a terminal, personal computer, Apple Macintosh, or workstation connected to the switch's console (serial) port.

There are two ways to use this management method: via direct access or modem port access. The following sections describe these methods. For more information about using the console, refer to **Chapter 4 Command Line Interface Console Management**.

3.1.2 Direct Access

Direct access to the administration console is achieved by directly connecting a terminal or a PC equipped with a terminal-emulation program (such as HyperTerminal) to the switch console (serial) port.

When using this management method, a null-modem cable is required to connect the switch to the PC. After making this connection, configure the terminal-emulation program to use the following parameters:

The default parameters are:

- 115,200 bps
- 8 data bits
- No parity
- 1 stop bit

You can change these settings, if desired, after you log on. This management method is often preferred because you can remain connected and monitor the system during system reboots. Also, certain error messages are sent to the serial port, regardless of the interface through which the associated action was initiated. A Macintosh or PC attachment can use any terminal-emulation program for connecting to the terminal serial port. A workstation

attachment under UNIX can use an emulator such as TIP.

3.2 Web Management

The switch provides a browser interface that lets you configure and manage the switch remotely. After you set up your IP address for the switch, you can access the switch's Web interface applications directly in your Web browser by entering the IP address of the switch. You can then use your Web browser to list and manage switch configuration parameters from one central location, just as if you were directly connected to the switch's console port.

Web Management requires either Microsoft Internet Explorer 4.01 or later or Netscape Navigator 4.03 or later.

3.3 SNMP-Based Network Management

You can use an external SNMP-based application to configure and manage the switch. This management method requires the SNMP agent on the switch and the SNMP Network Management Station to use the same community string. This management method, in fact, uses two community strings: the get community string and the set community string. If the SNMP Network management Station only knows the set community string, it can read and write to the MIBs. However, if it only knows the get community string, it can only read MIBs. The default gets and sets community strings for the switch are public.

3.4 Protocols

The switch supports the following protocols:

- Virtual terminal protocols, such as Telnet
- Simple Network Management Protocol (SNMP)

3.4.1 *Virtual Terminal Protocols*

A virtual terminal protocol is a software program, such as Telnet, that allows you to establish a management session from a Macintosh, a PC, or a UNIX workstation. Because Telnet runs over TCP/IP, you must have at least one IP address configured on the switch before you can establish access to it with a virtual terminal protocol.

Note: Terminal emulation differs from a virtual terminal protocol in that you must connect a terminal directly to the console (serial) port.

3.4.2 *SNMP Protocol*

Simple Network Management Protocol (SNMP) is the standard management protocol for multi-vendor IP networks. SNMP supports transaction-based queries that allow the protocol to format messages and to transmit information between reporting devices and data-collection programs. SNMP runs on top of the User Datagram Protocol (UDP), offering a connectionless-mode service.

3.4.3 Management Architecture

All of the management application modules use the same Messaging Application Programming Interface (MAPI). By unifying management methods with a single MAPI, configuration parameters set using one method (console port, for example) are immediately displayable by the other management methods (for example, SNMP agent or Web browser).

The management architecture of the switch adheres to the IEEE open standard. This compliance assures customers that the switch is compatible with, and will interoperate with other solutions that adhere to the same open standard.

4.0 Command Structure

The Command Line Interface (CLI) syntax, conventions and terminology are described in this section. Each CLI command referenced in this document is illustrated using the structure outlined below.

4.1 Format

Some commands, such as **show inventory** or **clear vlan**, do not require parameters. Other commands, such as **network parms**, have parameters for which you must supply a value. Parameters are positional — you must type the values in the correct order. Optional parameters will follow required parameters. For example:

Example 1

network parms <*ipaddr*> <*netmask*> [*gateway*]

- **network parms** is the command name.
- <*ipaddr*> <*netmask*> are the required values for the command.
- [*gateway*] is the optional value for the command.

Example 2

snmp-server location <*loc*>

- **snmp-server location** is the command name.
- <*loc*> is the required parameter for the command.

Example 3

clear vlan

- **clear vlan** is the command name.

4.1.1 Command

The following conventions apply to the command name:

- The command name is displayed in this document in bold font and must be typed exactly as shown.
- Once you have entered enough letters of a command name to uniquely identify the command, hitting the space bar or Tab key will cause the system to complete the word.
- Entering Ctrl-Z will return you to the root level command prompt.

4.1.2 Parameters

- Parameters are order dependent.

- Parameters are displayed in this document in bold italic font, which must be replaced with a name or number. To use spaces as part of a name parameter, enclose it in double quotes. For example, the expression "System Name with Spaces" forces the system to accept the spaces.
- Parameters may be mandatory values, optional values, choices, or a combination.
 - <parameter>. The <> angle brackets indicate that a mandatory parameter must be entered in place of the brackets and text inside them.
 - [parameter]. The [] square brackets indicate that an optional parameter may be entered in place of the brackets and text inside them.
 - choice1 | choice2. The | indicates that only one of the parameters should be entered.
 - The {} curly braces indicate that a parameter must be chosen from the list of choices.

4.1.3 Values

ipaddr This parameter is a valid IP address. Presently the IP address can be entered in following formats: a (32 bits)
 a.b (8.24 bits)
 a.b.c (8.8.16 bits)
 a.b.c.d (8.8.8.8)

In addition to these formats, decimal, hexadecimal and octal formats are supported through the following input formats (where n is any valid hexadecimal, octal or decimal number):

0xn (CLI assumes hexadecimal format)
0n (CLI assumes octal format with leading zeros)
 n (CLI assumes decimal format)

macaddr The MAC address format is six hexadecimal numbers separated by colons, for example 00:06:29:32:81:40.

areaid Area IDs may be entered in dotted-decimal notation (for example, 0.0.0.1). An area ID of 0.0.0.0 is reserved for the backbone. Area IDs have the same form as IP addresses, but are distinct from IP addresses. The IP network number of the sub-netted network may be used for the area ID.

routerid The value of <router id> must be entered in 4-digit dotted-decimal notation (for example, 0.0.0.1). A router ID of 0.0.0.0 is invalid.

unit/slot/port Valid unit, slot and port number separated by forward slashes. For example, 1/0/1 represents unit number 1, slot number 0 and port number 1.

logical unit/slot/port Logical unit, slot and port number. This is applicable in the case of a port-channel (LAG). The operator can use the logical unit/slot/port to configure the port-channel.

character strings Use double quotation marks to identify character strings, for example, "System Name with Spaces". An empty string ("") is not valid.

4.1.4 Conventions

- Network addresses are used to define a link to a remote host, workstation or network. Network addresses are shown using the following syntax:

Table 1. Network Address Syntax

Address Type	Format	Range
ipaddr	192.165.11.110	0.0.0.0 to 255.255.255.255 (decimal)
macaddr	A7:C9:89:DD:A9:B3	hexidecimal digit pairs

- Double quotation marks such as "System Name with Spaces" set off user defined strings. If the operator wishes to use spaces as part of a name parameter then it must be enclosed in double quotation marks.
- Empty strings ("") are not valid user defined strings.
- Command completion finishes spelling the command when enough letters of a command are typed to uniquely identify the command word. The command may be executed by typing <enter> (command abbreviation) or the command word may be completed by typing the <tab> or <space bar> (command completion). The value 'Err' designates that the requested value was not internally accessible. This should never happen and indicates that there is a case in the software that is not handled correctly.
- The value of '-----' designates that the value is unknown.

4.1.5 Annotations

The CLI allows the user to type single-line annotations at the command prompt for use when writing test or configuration scripts and for better readability. The exclamation point (!) character flags the beginning of a comment. The comment flag character can begin a word anywhere on the command line and all input following this character is ignored. Any command line that begins with the character '!' is recognized as a comment line and ignored by the parser.

Some examples are provided below:

! Script file for displaying the ip interface

! Display information about interfaces

```
show ip interface 1/0/1 !Displays the information about the first interface

! Display information about the next interface

show ip interface 1/0/2

! End of the script file
```

4.1.6 Special Characters

Certain special key combinations speed up use of the CLI. They are listed in this section.

Also, help is available for the CLI by typing **HELP**.

DEL, BS delete previous character

Ctrl-A go to beginning of line

Ctrl-E go to end of line

Ctrl-F go forward one character

Ctrl-B go backward one character

Ctrl-D delete current character

Ctrl-H display command history or retrieve a command

Ctrl-U, X delete to beginning of line

Ctrl-K delete to end of line

Ctrl-W delete previous word

Ctrl-T transpose previous character

Ctrl-P go to previous line in history buffer

Ctrl-N go to next line in history buffer

Ctrl-Z return to root command prompt

Tab, <SPACE> command-line completion

Exit to exit from the mode to the upper lower command prompt

5.0 Quick Start up

The CLI Quick Start up details procedures to quickly become acquainted with the the switch’s managed commands.

5.1 Quick Starting the Networking Device

1. Read the Chapter 2.0 for the connectivity procedure. In-band connectivity allows access to the Web and CLI command interface locally or from a remote workstation. The device must be configured with IP information (IP address, subnet mask, and default gateway).
2. Turn the Power ON.
3. Allow the device to load the software until the login prompt appears. The device initial state is called the default mode
4. When the prompt asks for operator login, execute the following steps:

Type the word **admin** in the login area. Since a number of the Quick Setup commands require administrator account rights, we suggests logging into an administrator account.

Do not enter a password because there is no password in the default mode. □

Press the enter key two times. □

The CLI User EXEC prompt will be displayed. □

Use “enable” to networking device to the Privileged EXEC mode from User EXEC.

Use “configure” to switch to the Global Config mode from Privileged EXEC.

Use “exit” to return to the previous mode.

5.2 System Info and System Setup

Quick Start up Software Version Information

Table 2 Quick Start up Software Version Information

Command	Details
show hardware (in Privileged EXEC)	Allows the user to see the software version the device contains
	Machine Model (The type and number of ports the device provides.)
	For example: Machine Model..... 24+2G 24 = 24 10/100 ports 02 = 2 Uplink ports on back of switch

Quick Start up Physical Port Data

Table 3 Quick Start up Physical Port Data

Command	Details
show port all (in Privileged EXEC)	Displays the Ports
	slot/port
	Type - Indicates if the port is a special type of port
	Admin Mode - Selects the Port Control Administration State
	Physical Mode - Selects the desired port speed and duplex mode
	Physical Status - Indicates the port speed and duplex mode
	Link Status - Indicates whether the link is up or down
	Link Trap - Determines whether or not to send a trap when link status changes
	LACP Mode - Displays whether LACP is enabled or disabled on this port.

Quick Start up User Account Management

Table 4 Quick Start up User Account Management

Command	Details
show users (in Privileged EXEC)	Displays all of the users that are allowed to access the switch
	Access Mode - Shows whether the user is able to change parameters on the switch (Read/Write) or is only able to view then (Read Only). As a factory default, the 'admin' user has Read/Write access and the 'guest' user has Read Only access. There can only be one Read/Write user and up to five Read Only users.
show login session (in User EXEC)	Displays all of the login session information
users passwd <username> (in Global Config)	Allows the user to set passwords or change passwords needed to login A prompt will appear after the command is entered requesting the users old password. In the absence of an old password leave the area blank. The operator must press enter to execute the command. The system then prompts the user for a new password then a prompt to confirm the new password. If the new password and the confirmed password match a message will be displayed. User password should not be more than eight characters in length.
copy system:running-config nvram:startup-config (in Privileged EXEC)	This will save passwords and all other changes to the device. If you do not save the configuration by doing this command, all configurations will be lost when a power cycle is performed on the switch or when the switch is reset
logout (in User EXEC and Privileged EXEC)	Logs the user out of the switch

Quick Start up IP Address

To view the network parameters the operator can access the device by the following three methods.

- ◆ Simple Network Management Protocol - SNMP
- ◆ Telnet
- ◆ Web Browser

Note: Helpful Hint: The user should do a 'copy system:running-config nvram:startup-config' after configuring the network parameters so that the configurations are not lost

Table 5 Quick Start up IP Address

Command	Details
show network (in User EXEC)	Displays the Network Configurations
	IP Address - IP Address of the interface Default IP is 0.0.0.0
	Subnet Mask - IP Subnet Mask for the interface Default is 0.0.0.0
	Default Gateway - The default Gateway for this interface Default value is 0.0.0.0
	Burned in MAC Address - The Burned in MAC Address used for in-band connectivity
	Locally Administered MAC Address - Can be configured to allow a locally administered MAC address
	MAC Address Type - Specifies which MAC address should be used for in-band connectivity
	Network Configurations Protocol Current - Indicates which network protocol is being used Default is none
	Management VLAN Id - Specifies VLAN id
	Web Mode - Indicates whether HTTP/Web is enabled.
	Java Mode - Indicates whether java mode is enabled.
network parms (in Privileged EXEC)	network parms <ipaddr> <netmask> [<gateway>]
	IP Address range from 0.0.0.0 to 255.255.255.255
	Subnet Mask range from 0.0.0.0 to 255.255.255.255
	Gateway Address range from 0.0.0.0 to 255.255.255.255

Quick Start up Uploading from Switch to Out-of-Band PC (Only XMODEM)

Table 6 Quick Start up Uploading from Switch to Out-of-Band PC (XMODEM)

Command	Details
<code>copy { nvram:startup-config / nvram:errorlog nvram:msglog nvram:traplog} <url></code>	The types are: config - configuration file errorlog - error log system trace - system trace traplog - trap log The URL must be specified as: xmodem:filepath/fileName
	This starts the upload and also displays the mode of uploading and the type of upload it is and confirms the upload is taking place. For example: If the user is using HyperTerminal, the user must specify where the file is going to be received by the PC.

Quick Start up Downloading from Out-of-Band PC to Switch (Only XMODEM)

Table 7 Quick Start up Downloading from Out-of-Band PC to Switch (Only XMODEM)

Command	Details
<code>copy <url> {nvram:startup-config system: image}</code>	Sets the destination (download) data type to be an image (system:image) or a configuration file (nvram:startup-config). The URL must be specified as: xmodem:filepath/fileName
	For example: If the user is using HyperTerminal, the user must specify which file is to be sent to the switch. The Switch will restart automatically once the code has been downloaded.

Quick Start up Downloading from TFTP Server

Before starting a TFTP server download, the operator must complete the Quick Start up for the IP Address.

Table 8 Quick Start up Downloading from TFTP Server

Command	Details
<code>copy <url> {nvram:startup-config system: image}</code>	Sets the destination (download) data type to be an image (system:image) or a configuration file (nvram:startup-config). The URL must be specified as: tftp://ipAddr/filepath/fileName. The nvram:startup-config option downloads the configuration file using tftp and system:image option downloads the code file.

Quick Start up Factory Defaults

Table 9 Quick Start up Factory Defaults

Command	Details
clear config	Enter yes when the prompt pops up to clear all the configurations made to the switch.
copy system:running-config nvram:startup-config	Enter yes when the prompt pops up that asks if you want to save the configurations made to the switch.
reload OR Cold Boot the Switch	Enter yes when the prompt pops up that asks if you want to reset the system. This is the users choice either reset the switch or cold boot the switch, both work effectively.

6.0 Mode-based Command Line Interface

The Command Line Interface (CLI) groups all the commands in appropriate modes according to the nature of the commands. Sample of the CLI command modes are described below. Each of the command modes supports specific switch's commands.

The CLI Command Modes table captures the command modes, the prompts visible in that mode and the exit method from that mode.

Table 10. CLI Command Modes

Command Mode	Access Method	Prompt	Exit or Access Previous Mode
User Exec Mode	This is the first level of access. Perform basic tasks and list system information.	Switch>	Enter Logout command
Privileged Exec Mode	From the User Exec mode, enter the enable command.	Switch#	To exit to the User Exec mode, enter exit or press Ctrl-Z.
VLAN Mode	From the Privileged Exec mode, enter the vlan database command.	Switch (Vlan) #	To exit to the Privileged Exec mode, enter the exit command, or press Ctrl-Z to switch to the User Exec mode.
Global Config Mode	From the Privileged Exec mode, enter the con-figure command.	Switch (Config)#	To exit to the Privileged Exec mode, enter the exit command, or press Ctrl-Z to switch to the User Exec mode.
Interface Config Mode	From the Global Config mode, enter the inter-face <unit/slot/ port> command.	Switch (Interface "if number")#	To exit to the Global Config mode, enter exit. To return to the User Exec mode, enter ctrl-Z.
Line Config Mode	From the Global Config mode, enter the lineconfig command	Switch (line) #	To exit to the Global Config mode, enter exit. To return to the User Exec mode, enter ctrl-Z.

Command Mode	Access Method	Prompt	Exit or Access Previous Mode
Policy Map Con-fig Mode	From the Global Config mode, enter the pol-icy-map command	Switch (Config-policy-map)#	To exit to the Global Config mode, enter exit. To return to the User Exec mode, enter ctrl-Z.
Policy Class Config Mode	From the Policy Map mode enter the class command	Switch (Config-policy-classmap)#	To exit to the Policy Map mode, enter exit. To return to the User Exec mode, enter ctrl-Z.
Class Map Con-fig Mode(only for Layer 3 Series)	From the Global Config mode, enter the class-map command	Switch (Config-classmap)#	To exit to the Global Config mode, enter exit. To return to the User Exec mode, enter ctrl-Z.
Router OSPF Config Mode (only for Layer 3 Series)	From the Global Config mode, enter the router ospf command	Switch (Config-router)#	To exit to the Global Config mode, enter exit. To return to the User Exec mode, enter ctrl-Z.
Router RIP Config Mode(only for Layer 3 Series)	From the Global Config mode, enter the router rip command	Switch (Config-router)#	To exit to the Global Config mode, enter exit. To return to the User Exec mode, enter ctrl-Z.
Router BGP Config Mode (only for Layer 3 Series)	From the Global Config mode, enter the router bgp <i><asnum-ber></i> command	Switch (Config-router)#	To exit to the Global Config mode, enter exit. To return to the User Exec mode, enter ctrl-Z.
Bwprovisioning Config Mode	From the Global Config mode, enter the bwpro- visioning command.	Switch (Config-bwp)#	To exit to the Global Config mode, enter exit. To return to the User Exec mode, enter ctrl-Z.

Command Mode	Access Method	Prompt	Exit or Access Previous Mode
Bwprovisioning - Trafficclass Con-fig Mode	From the Bwprovisioning mode, enter the traf-ic-class command.	Switch (Config-bwp-trafficclass)#	To exit to the Bwprovisioning Config mode, enter exit. To return to the User Exec mode, enter ctrl-Z.
Bwprovisioning - bwallocation Config Mode	From the Bwprovisioning mode, enter the bwal-location command.	Switch (Config-bwp-bwallocation)#	To exit to the Bwprovisioning mode, enter exit. To return to the User Exec mode, enter ctrl-Z.
MAC Access-list Config Mode	From the Global Config mode enter the mac access-list extended <name> command	Switch (Config-mac-access-list)#	To exit to the Global Config mode, enter exit. To return to the User Exec mode, enter ctrl-Z.
DHCP Pool Con-fig Mode	From the Global Config mode, enter the ipdhcp pool<pool-name> command.	Switch (Config-dhcp-pool)#	To exit to the Global Config mode, enter exit. To return to the User Exec mode, enter ctrl-Z
Stack Global Config Mode	From the Global Config mode, enter the stack command.	Switch (Config-stack)#	To exit to the Global Config mode, enter exit. To return to the User Exec mode, enter ctrl-Z

6.1 Mode-based Topology

The CLI tree is built on a mode concept where the commands are available according to the interface. Some of the modes are depicted in the mode-based CLI Figure 1.

Figure 1. Mode-based CLI

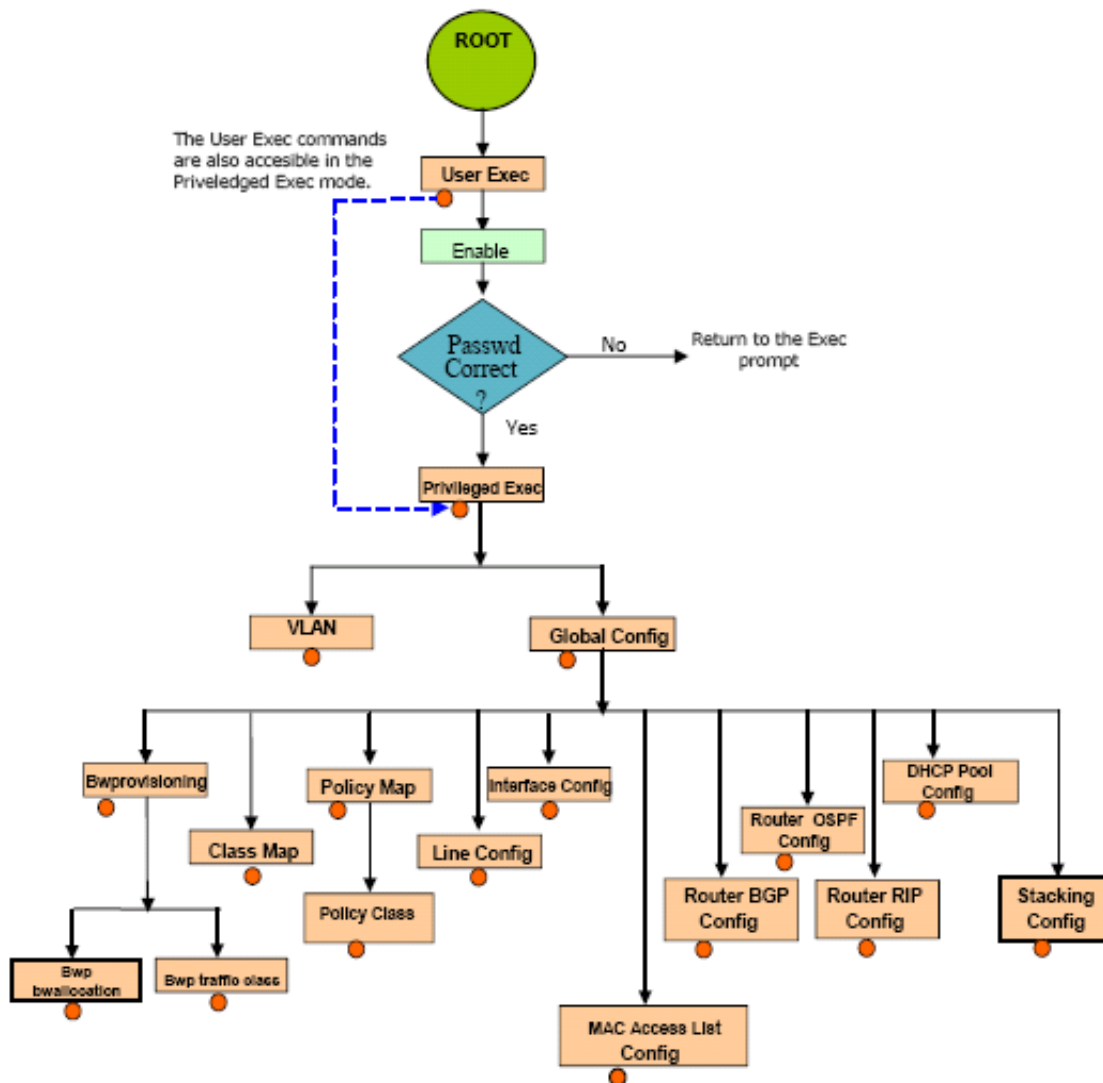

Access to all commands in the Privileged Exec mode and below are restricted through a password.

6.2 Mode-based Command Hierarchy

The CLI is divided into various modes. The Commands in one mode are not available until the operator switches to that particular mode, with the exception of the User Exec mode commands. The User Exec mode commands may also be executed in the Privileged Exec mode. The commands available to the operator at any point in time depend upon the mode. Entering a question mark (?) at the CLI prompt, displays a list of the available commands and descriptions of the commands.

The CLI provides the following modes:

User Exec Mode

When the operator logs into the CLI, the User Exec mode is the initial mode. The User Exec mode contains a limited set of commands. The command prompt shown at this level is:

Command Prompt: \$>

Privileged Exec Mode

To have access to the full suite of commands, the operator must enter the Privileged Exec mode. The Privileged Exec mode requires password authentication. From Privileged Exec mode, the operator can issue any Exec command, enter the VLAN mode or enter the Global Configuration mode. The command prompt shown at this level is:

Command Prompt: \$#

VLAN Mode

This mode groups all the commands pertaining to VLANs. The command prompt shown at this level is:

Command Prompt: \$(VLAN)#

Global Config Mode

This mode permits the operator to make modifications to the running configuration. General setup commands are grouped in this mode. From the Global Configuration mode, the operator can enter the System Configuration mode, the Physical Port Configuration mode, the Interface Configuration mode, or the Protocol Specific modes specified below. The command prompt at this level is:

Command Prompt: \$(Config)#

From the Global Config mode, the operator may enter the following configuration modes:

Interface Config Mode

Many features are enabled for a particular interface. The Interface commands enable or modify

the operation of an interface. In this mode, a physical port is set up for a specific logical connection operation. The Interface Config mode provides access to the router interface configuration commands. The command prompt at this level is:

Command Prompt: \$(Interface <unit/slot/port>)#

The resulting prompt for the interface configuration command entered in the Global Configuration mode is shown below:

\$(Config)# interface 1/2/1

\$(Interface 1/2/1)#+

Line Config Mode

This mode allows the operator to configure the console interface. The operator may configure the interface from the directly connected console or the virtual terminal used with Telnet. The command prompt at this level is:

Command Prompt: \$(Line)#

Policy Map Mode

Use the policy-map <policy-name>command to access the QoS policy map configuration mode to configure the QoS policy map.

\$(Config)# policy map <policy name> Command

Prompt: \$(Config-policy-map)#

Policy Class Mode

Use the class <class-name> command to access the QoS policy-classmap mode to attach/remove a diffserv class to a policy and to configure the QoS policy class.

\$(Config policy-map)# class <class name> Command

Prompt: \$(Config-policy-classmap)#

Class Map Mode:

This mode consists of class creation/deletion and matching commands. The class match commands specify Layer 2, Layer 3 and general match criteria. Use the class-map class-map-name commands to access the QoS class map configuration mode to configure QoS class maps.

\$(Config)# class-map <class-map-name> Command

Prompt: \$(Config class-map)#

Router OSPF Config Mode:

In this mode, the operator is allowed to access the router OSPF configuration commands. The command prompt at this level is:

\$(Config)# router ospf Command Prompt:

\$(Config router)#

Router RIP Config Mode:

In this mode, the operator is allowed to access the router RIP configuration commands. The command prompt at this level is:

\$(Config)# router rip Command Prompt:

\$(Config router)#

Router BGP Config Mode:

In this mode, the operator is allowed to access the router BGP4 configuration commands. The command prompt at this level is:

\$(Config)# router bgp <1-65535> Command

Prompt: **\$(Config-routerbgp)#**

Bwprovisioning Config Mode

Use the **bwprovisioning** command to access the Bandwidth provisioning Config Mode to configure bandwidth provisioning.

\$(Config)# bwprovisioning Command

Prompt: **\$(Config-bwp)#**

Bwprovisioning Trafficclass Mode

Use the **traffic-class** command to access the Bandwidth provisioning Config Mode to configure bandwidth traffic class.

\$(Config bwp)# traffic-classCommand Prompt: \$(Config-bwp-trafficclass)#

Bwprovisioning bwallocation Mode

Use the **bwallocation** command to access the Bandwidth provisioning Config Mode to configure bandwidth allocation.

\$(Config bwp)# bwallocation

Command Prompt: **\$(Config bwp-bwallocation)#**

MAC Access-List Config Mode

Use the MAC Access-List Config mode to create a MAC access-List and to enter the mode containing mac access-list configuration commands.

\$(Config)# mac-access-list extended <name>

Command Prompt: **\$(Config-mac-access-list)#**

DHCP Pool Config Mode

Use the **ip dhcp pool <pool-name>** command to access the DHCP Pool Config .

\$(Config)# ip dhcp pool <pool-name>

Command Prompt: **(Config-dhcp-pool)#**

Stack Global Config Mode

Use the **stack** command to access the Stack Config Mode.

\$(Config)# stack

Command Prompt: **(Config-stack)#**

6.3 Flow of Operation

This section captures the flow of operation for the CLI:

1. The operator logs into the CLI session and enters the User Exec mode. In the User Exec mode the \$(exec)> prompt is displayed on the screen.

The parsing process is initiated whenever the operator types a command and presses <ENTER>. The command tree is searched for the command of interest. If the command is not found, the output message indicates where the offending entry begins. For instance, command node A has the command "show arp brief" but the operator attempts to execute the command "show arpp brief" then the output message would be \$(exec)> show arpp brief^ **%Invalid input detected at '^' marker**. If the operator has given an invalid input parameter in the command, then the message conveys to the operator an invalid input was detected. The layout of the output is depicted below:

Syntax Error Message:

```
(exec) #show arpp brief
```

```
^
```

```
%Invalid input detected at '^' marker.
```

After all the mandatory parameters are entered, any additional parameters entered are treated as optional parameters. If any of the parameters are not recognized a syntax error message will be displayed.

2. After the command is successfully parsed and validated, the control of execution goes to the corresponding CLI callback function.
3. For mandatory parameters, the command tree extends till the mandatory parameters make the leaf of the branch. The callback function is only invoked when all the mandatory parameters are provided. For optional parameters, the command tree extends till the mandatory parameters and the optional parameters make the leaf of the branch. However, the call back function is associated with the node where the mandatory parameters are fetched. The call back function then takes care of the optional parameters.
4. Once the control has reached the callback function, the callback function has complete information about the parameters entered by the operator.

6.4 “No” Form of a Command

“No” is a specific form of an existing command and does not represent a new or distinct command. Only the configuration commands are available in the “no” form. The behavior and the support details of the “no” form is captured as part of the mapping sheets.

6.4.1 Support for “No” Form

Almost every configuration command has a “no” form. In general, use the no form to reverse the action of a command or reset a value back to the default. For example, the **no shutdown interface** configuration command reverses the shutdown of an interface. Use the command without the keyword no to re-enable a disabled feature or to enable a feature that is disabled by default.

7.0 Switching Commands

This chapter provides detailed explanation of the Switching commands. The commands are divided into five functional groups:

- Show commands display switch settings, statistics, and other information. □
- Configuration commands configure features and options of the switch. For every configuration command, there is a show command that displays the configuration setting.
- Copy commands transfer or save configuration and informational files to and from the switch.
- Clear commands clear some or all of the settings to factory defaults.

This chapter includes the following configuration types:

- System information and statistics commands □
- System Management commands □
- Device configuration commands □
- User account management commands □
- Security commands □
- System utilities

7.1 System Information and Statistics Commands

This chapter provides a detailed explanation of the CLI commands. The commands are divided into five functional groups:

- Show commands display switch settings, statistics, and other information. □
- Configuration commands configure features and options of the switch. For every configuration command, there is a show command that displays the configuration setting.
- Copy commands transfer or save configuration and informational files to and from the switch. □
- Clear commands clear some or all of the settings to factory defaults.

7.1.1 *show arp switch*

This command displays connectivity between the switch and other devices. The Address Resolution Protocol (ARP) cache identifies the MAC addresses of the IP stations communicating with the switch.

Format `show arp switch`

Mode Privileged EXEC

MAC Address A unicast MAC address for which the switch has forwarding and/or filtering information. The format is 6 two-digit hexadecimal numbers that are separated by colons, for example 01:23:45:67:89:AB

IP Address The IP address assigned to each interface.

unit/slot/port Valid unit, slot and port number separated by forward slashes.

7.1.2 show eventlog

This command displays the event log, which contains error messages from the system. The event log is not cleared on a system reset.

Format show eventlog

Mode Privileged EXEC

File The file in which the event originated.

Line The line number of the event.

Task Id The task ID of the event.

Code The event code.

Time The time this event occurred.

Note: Event log information is retained across a switch reset.

7.1.3 show hardware

This command displays inventory information for the switch.

Format show hardware

Mode Privileged EXEC

Switch Description Text used to identify the product name of this switch.

Machine Type Specifies the machine model as defined by the Vital Product Data.

Machine Model Specifies the machine model as defined by the Vital Product Data.

Serial Number The unique box serial number for this switch.

FRU Number The field replaceable unit number.

Part Number Manufacturing part number.

Maintenance Level Indicates hardware changes that are significant to software.

Manufacturer Manufacture descriptor field.

Burned in MAC Address Universally assigned network address.

Software Version The release version revision number of the code currently running on the switch.

Operating System The operating system currently running on the switch.

Network Processing Element The type of the processor micro-code.

Additional Packages This displays the additional packages that are incorporated into this system, such as BGP-4, or Multicast.

7.1.4 show interface

This command displays a summary of statistics for a specific port or a count of all CPU traffic based upon the argument.

Format show interface {<unit/slot/port> / *switchport*}

Mode Privileged EXEC

The display parameters, when the argument is '<unit/slot/port>', is as follows :

Packets Received Without Error The total number of packets (including broadcast packets and multicast packets) received by the processor.

Packets Received With Error The number of inbound packets that contained errors preventing them from being deliverable to a higher-layer protocol.

Broadcast Packets Received The total number of packets received that were directed to the broadcast address. Note that this does not include multicast packets.

Packets Transmitted Without Error The total number of packets transmitted out of the interface.

Transmit Packets Errors The number of outbound packets that could not be transmitted because of errors.

Collisions Frames The best estimate of the total number of collisions on this Ethernet segment.

Time Since Counters Last Cleared The elapsed time, in days, hours, minutes, and seconds since the statistics for this port were last cleared.

The display parameters, when the argument is 'switchport', is as follows :

Packets Received Without Error The total number of packets (including broadcast packets and multicast packets) received by the processor.

Broadcast Packets Received The total number of packets received that were directed to the broadcast address. Note that this does not include multicast packets.

Packets Received With Error The number of inbound packets that contained errors preventing them from being deliverable to a higher-layer protocol.

Packets Transmitted Without Error The total number of packets transmitted out of the interface.

Broadcast Packets Transmitted The total number of packets that higher-level protocols requested to be transmitted to the Broadcast address, including those that were discarded or not sent.

Transmit Packet Errors The number of outbound packets that could not be transmitted because of errors.

Address Entries Currently In Use The total number of Forwarding Database Address Table entries now active on the switch, including learned and static entries.

VLAN Entries Currently In Use The number of VLAN entries presently occupying the VLAN table.

Time Since Counters Last Cleared The elapsed time, in days, hours, minutes, and seconds since the statistics for this switch were last cleared.

7.1.5 show interface ethernet

This command displays detailed statistics for a specific port or for all CPU traffic based upon the argument.

Format show interface ethernet {<unit/slot/port> | *switchport*}

Mode Privileged EXEC

The display parameters, when the argument is '<unit/slot/port>', are as follows :

Packets Received

Octets Received - The total number of octets of data (including those in bad packets) received on the network (excluding framing bits but including Frame Check Sequence (FCS) octets). This object can be used as a reasonable estimate of ethernet utilization. If greater precision is desired, the etherStatsPkts and etherStatsOctets objects should be sampled before and after a common interval. ----- The result of this equation is the value Utilization which is the percent utilization of the ethernet segment on a scale of 0 to 100 percent.
Packets Received < 64 Octets - The total number of packets (including bad packets) received that were < 64 octets in length (excluding framing bits but including FCS octets).

Packets Received 64 Octets - The total number of packets (including bad packets) received that were 64 octets in length (excluding framing bits but including FCS octets).

Packets Received 65-127 Octets - The total number of packets (including bad packets) received that were between 65 and 127 octets in length inclusive (excluding framing bits but including FCS octets).

Packets Received 128-255 Octets - The total number of packets (including bad packets) received that were between 128 and 255 octets in length inclusive (excluding framing bits but including FCS octets).

Packets Received 256-511 Octets - The total number of packets (including bad packets) received that were between 256 and 511 octets in length inclusive (excluding framing bits but including FCS octets).

Packets Received 512-1023 Octets - The total number of packets (including bad packets) received that were between 512 and 1023 octets in length inclusive (excluding framing bits but including FCS octets).

Packets Received 1024-1518 Octets - The total number of packets (including bad packets) received that were between 1024 and 1518 octets in length inclusive (excluding framing bits but including FCS octets).

Packets Received 1519-1522 Octets - The total number of packets (including bad packets) received that were between 1519 and 1522 octets in length inclusive (excluding framing bits but including FCS octets).

Packets Received > 1522 Octets - The total number of packets received that were longer than 1522 octets (excluding framing bits, but including FCS octets) and were otherwise well formed.

Packets Received Successfully

Total - The total number of packets received that were without errors.

Unicast Packets Received - The number of subnetwork-unicast packets delivered to a higher-layer protocol.

Multicast Packets Received - The total number of good packets received that were directed to a multicast address. Note that this number does not include packets directed to the broadcast address.

Broadcast Packets Received - The total number of good packets received that were directed to the broadcast address. Note that this does not include multicast packets.

Packets Received with MAC Errors

Total - The total number of inbound packets that contained errors preventing them from being deliverable to a higher-layer protocol.

Jabbers Received - The total number of packets received that were longer than 1518 octets (excluding framing bits, but including FCS octets), and had either a bad Frame Check Sequence (FCS) with an integral number of octets (FCS Error) or a bad FCS with a non-integral number of octets (Alignment Error). Note that this definition of jabber is different than the definition in IEEE-802.3 section 8.2.1.5 (10BASE5) and section 10.3.1.4 (10BASE2). These documents define jabber as the condition where any packet exceeds 20 ms. The allowed range to detect jabber is between 20 ms and 150 ms.

Fragments/Undersize Received - The total number of packets received that were less than 64 octets in length (excluding framing bits but including FCS octets).

Alignment Errors - The total number of packets received that had a length (excluding framing bits, but including FCS octets) of between 64 and 1518 octets, inclusive, but had a bad Frame Check Sequence (FCS) with a non-integral number of octets.

Rx FCS Errors - The total number of packets received that had a length (excluding framing bits, but including FCS octets) of between 64 and 1518 octets, inclusive, but had a bad Frame Check Sequence (FCS) with an integral number of octets

Overruns - The total number of frames discarded as this port was overloaded with incoming packets, and could not keep up with the inflow.

Received Packets not forwarded

Total - A count of valid frames received which were discarded (i.e. filtered) by the forwarding process.

Local Traffic Frames - The total number of frames dropped in the forwarding process because the destination address was located off of this port.

802.3x Pause Frames Received - A count of MAC Control frames received on this interface with an op-code indicating the PAUSE operation. This counter does not increment when the interface is operating in half-duplex mode.

Unacceptable Frame Type - The number of frames discarded from this port due to being an unacceptable frame type.

VLAN Membership Mismatch - The number of frames discarded on this port due to ingress filtering.

VLAN Viable Discards - The number of frames discarded on this port when a lookup on a particular VLAN occurs while that entry in the VLAN table is being modified, or if the VLAN has not been configured.

Multicast Tree Viable Discards - The number of frames discarded when a lookup in the multicast tree for a VLAN occurs while that tree is being modified.

Reserved Address Discards - The number of frames discarded that are destined to an IEEE 802.1 reserved address and are not supported by the system.

Broadcast Storm Recovery - The number of frames discarded that are destined for FF:FF:FF:FF:FF:FF when Broadcast Storm Recovery is enabled.

CFI Discards - The number of frames discarded that have CFI bit set and the addresses in RIF are in non-canonical format.

Upstream Threshold - The number of frames discarded due to lack of cell descriptors available for that packet's priority level.

Packets Transmitted Octets

Total Bytes - The total number of octets of data (including those in bad packets) received on the network (excluding framing bits but including FCS octets). This object can be used as a reasonable estimate of ethernet utilization. If greater precision is desired, the etherStatsPkts and etherStatsOctets objects should be sampled before and

after a common interval.

Packets Transmitted 64 Octets - The total number of packets (including bad packets) received that were 64 octets in length (excluding framing bits but including FCS octets).

Packets Transmitted 65-127 Octets - The total number of packets (including bad packets) received that were between 65 and 127 octets in length inclusive (excluding framing bits but including FCS octets).

Packets Transmitted 128-255 Octets - The total number of packets (including bad packets) received that were between 128 and 255 octets in length inclusive (excluding framing bits but including FCS octets).

Packets Transmitted 256-511 Octets - The total number of packets (including bad packets) received that were between 256 and 511 octets in length inclusive (excluding framing bits but including FCS octets).

Packets Transmitted 512-1023 Octets - The total number of packets (including bad packets) received that were between 512 and 1023 octets in length inclusive (excluding framing bits but including FCS octets).

Packets Transmitted 1024-1518 Octets - The total number of packets (including bad packets) received that were between 1024 and 1518 octets in length inclusive (excluding framing bits but including FCS octets).

Packets Transmitted 1519-1522 Octets - The total number of packets (including bad packets) received that were between 1519 and 1522 octets in length inclusive (excluding framing bits but including FCS octets).

Max Info - The maximum size of the Info (non-MAC) field that this port will receive or transmit.

Packets Transmitted Successfully

Total - The number of frames that have been transmitted by this port to its segment.

Unicast Packets Transmitted - The total number of packets that higher-level protocols requested be transmitted to a subnetwork-unicast address, including those that were discarded or not sent.

Multicast Packets Transmitted - The total number of packets that higher-level protocols requested be transmitted to a Multicast address, including those that were discarded or not sent.

Broadcast Packets Transmitted - The total number of packets that higher-level protocols requested be transmitted to the Broadcast address, including those that were discarded or not sent.

Transmit Errors

Total Errors - The sum of Single, Multiple, and Excessive Collisions.

Tx FCS Errors - The total number of packets transmitted that had a length (excluding framing bits, but including FCS octets) of between 64 and 1518 octets, inclusive, but had a bad Frame Check Sequence (FCS) with an integral number of octets.

Oversized - The total number of frames that exceeded the max permitted frame size. This counter has a max increment rate of 815 counts per sec. at 10 Mb/s.

Underrun Errors - The total number of frames discarded because the transmit FIFO buffer became empty during frame transmission.

Transmit Discards

Total Discards - The sum of single collision frames discarded, multiple collision frames discarded, and excessive frames discarded.

Single Collision Frames - A count of the number of successfully transmitted frames on a particular interface for which transmission is inhibited by exactly one collision.

Multiple Collision Frames - A count of the number of successfully transmitted frames on a particular interface for which transmission is inhibited by more than one collision.

Excessive Collisions - A count of frames for which transmission on a particular interface fails due to excessive collisions.

Port Membership - The number of frames discarded on egress for this port due to egress filtering being enabled.

VLAN Viable Discards - The number of frames discarded on this port when a lookup on a particular VLAN occurs while that entry in the VLAN table is being modified, or if the VLAN has not been configured.

Protocol Statistics

BPDU's received - The count of BPDU's (Bridge Protocol Data Units) received in the spanning tree layer.

BPDU's Transmitted - The count of BPDU's (Bridge Protocol Data Units) transmitted from the spanning tree layer.

802.3x Pause Frames Received - A count of MAC Control frames received on this interface with an opcode indicating the PAUSE operation. This counter does not increment when the interface is operating in half-duplex mode.

GVRP PDU's Received - The count of GVRP PDU's received in the GARP layer.

GVRP PDU's Transmitted - The count of GVRP PDU's transmitted from the GARP layer.

GVRP Failed Registrations - The number of times attempted GVRP registrations could not be completed.

GMRP PDU's received - The count of GMRP PDU's received in the GARP layer.

GMRP PDU's Transmitted - The count of GMRP PDU's transmitted from the GARP layer.

GMRP Failed Registrations - The number of times attempted GMRP registrations could not be completed.

STP BPDUs Transmitted - Spanning Tree Protocol Bridge Protocol Data Units sent.

STP BPDUs Received - Spanning Tree Protocol Bridge Protocol Data Units received.

RST BPDUs Transmitted - Rapid Spanning Tree Protocol Bridge Protocol Data Units sent.

RSTP BPDUs Received - Rapid Spanning Tree Protocol Bridge Protocol Data Units received.

MSTP BPDUs Transmitted - Multiple Spanning Tree Protocol Bridge Protocol Data Units sent.

MSTP BPDUs Received - Multiple Spanning Tree Protocol Bridge Protocol Data Units received

Dot1x Statistics

EAPOL Frames Received - The number of valid EAPOL frames of any type that have been received by this authenticator.

EAPOL Frames Transmitted - The number of EAPOL frames of any type that have been transmitted by this authenticator.

Time Since Counters Last Cleared - The elapsed time, in days, hours, minutes, and seconds since the statistics for this port were last cleared.

The display parameters, when the argument is 'switchport', are as follows :

Octets Received - The total number of octets of data received by the processor (excluding framing bits but including FCS octets).

Total Packets Received Without Error- The total number of packets (including broadcast packets and multicast packets) received by the processor.

Unicast Packets Received - The number of subnetwork-unicast packets delivered to a higher-layer protocol.

Multicast Packets Received - The total number of packets received that were directed to a multicast address. Note that this number does not include packets directed to the broadcast address.

Broadcast Packets Received - The total number of packets received that were directed to the broadcast address. Note that this does not include multicast packets.

Receive Packets Discarded - The number of inbound packets which were chosen to be discarded even though no errors had been detected to prevent their being deliverable to a higher-layer protocol. A possible reason for discarding a packet could be to free up buffer space.

Octets Transmitted - The total number of octets transmitted out of the interface, including framing characters.

Packets Transmitted without Errors - The total number of packets transmitted out of the interface.

Unicast Packets Transmitted - The total number of packets that higher-level protocols requested be transmitted to a subnetwork-unicast address, including those that were discarded or not sent.

Multicast Packets Transmitted - The total number of packets that higher-level protocols requested be transmitted to a Multicast address, including those that were discarded or not sent.

Broadcast Packets Transmitted - The total number of packets that higher-level protocols requested be transmitted to the Broadcast address, including those that were discarded or not sent.

Transmit Packets Discarded - The number of outbound packets which were chosen to be discarded even though no errors had been detected to prevent their being deliverable to a higher-layer protocol. A possible reason for discarding a packet could be to free up buffer space.

Most Address Entries Ever Used - The highest number of Forwarding Database Address Table entries that have been learned by this switch since the most recent reboot.

Address Entries in Use - The number of Learned and static entries in the Forwarding Database Address Table for this switch.

Maximum VLAN Entries - The maximum number of Virtual LANs (VLANs) allowed on this switch.

Most VLAN Entries Ever Used - The largest number of VLANs that have been active on this switch since the last reboot.

Static VLAN Entries - The number of presently active VLAN entries on this switch that have been created statically.

Dynamic VLAN Entries - The number of presently active VLAN entries on this switch that have been created by GVRP registration.

VLAN Deletes - The number of VLANs on this switch that have been created and then deleted since the last reboot.

Time Since Counters Last Cleared The elapsed time, in days, hours, minutes, and seconds, since the statistics for this switch were last cleared.

7.1.6 show logging

This command displays the trap log maintained by the switch. The trap log contains a maximum of 256 entries that wrap.

Format show logging

Mode Privileged EXEC

Number of Traps since last reset The number of traps that have occurred since the last reset of this device.

Number of Traps since log last displayed The number of traps that have occurred since the traps were last displayed. Getting the traps by any method (terminal interface display, Web display, upload file from switch etc.) will result in this counter being cleared to 0.

Log The sequence number of this trap.

System Up Time The relative time since the last reboot of the switch at which this trap occurred.

Trap The relevant information of this trap.

Note: *Trap log information is not retained across a switch reset.*

7.1.7 show mac-addr-table

This command displays the forwarding database entries. If the command is entered with no parameter, the entire table is displayed. This is the same as entering the optional *all* parameter. Alternatively, the administrator can enter a MAC Address to display the table entry for the requested MAC address and all entries following the requested MAC address.

Format show mac-addr-table [<macaddr> | all]

Mode Privileged EXEC

Mac Address A unicast MAC address for which the switch has forwarding and or filtering information. The format is 6 or 8 two-digit hexadecimal numbers that are separated by colons, for example 01:23:45:67:89:AB. In an IVL system the MAC address will be displayed as 8 bytes.

Unit/Slot/Port The port which this address was learned.

if Index This object indicates the if Index of the interface table entry associated with this port.

Status The status of this entry. The meanings of the values are.

Static The value of the corresponding instance was added by the system or a user when a static MAC filter was defined. It cannot be relearned.

Learned The value of the corresponding instance was learned by observing the source MAC addresses of incoming traffic, and is currently in use.

Management The value of the corresponding instance (system MAC address) is also the value of an existing instance of dot1dStaticAddress. It is identified with interface 0/1 and is currently used when enabling VLANs for routing.

Self The value of the corresponding instance is the address of one of the switch's physical interfaces (the system's own MAC address).

GMRP Learned The value of the corresponding was learned via GMRP and applies to Multicast.

Other The value of the corresponding instance does not fall into one of the other categories.

7.1.8 *show running-config*

This command is used to display/capture the current setting of different protocol packages supported on the switch. This command displays/captures only commands with settings/configurations with values that differ from the default value. The output is displayed in script format, which can be used to configure another switch with the same configuration. If the optional <scriptname> is provided with a filename extension of “.scr”, the output will be redirected to a script file.

The option [all] will also enable the display/capture of all commands with settings/configurations that include values that are the same as the default values. The <scriptname> option cannot be used with the [all] option.

Format show running-config [all | <scriptname>]

Mode Privileged EXEC

7.1.9 *show sysinfo*

This command displays switch information.

Format show sysinfo

Mode Privileged EXEC

Switch Description Text used to identify this switch.

System Name Name used to identify the switch.

System Location Text used to identify the location of the switch. May be up to 31 alpha-numeric characters. The factory default is blank.

System Contact Text used to identify a contact person for this switch. May be up to 31 alpha-numeric characters. The factory default is blank.

System ObjectID The base object ID for the switch's enterprise MIB.

System Up Time The time in days, hours and minutes since the last switch reboot.

MIBs Supported A list of MIBs supported by this agent.

7.1.10 *snmp-server*

This command sets the name and the physical location of the switch, and the organization responsible for the network. The range for name, location and contact is from 1 to 31 alphanumeric characters.

Default none

Format snmp-server {sysname <name> | location <loc> | contact <con>}

Mode Global Config

7.2 System Management Commands

These commands manage the switch and show current management settings. The commands are divided into two functional groups:

- Show commands display switch settings, statistics, and other information.
- Configuration commands configure features and options of the switch. For every configuration command, there is a show command that displays the configuration setting.

7.2.1 *telnet*

This command establishes a new outbound telnet connection to a remote host. The *host* value must be a valid IP address. Valid values for *port* should be a valid decimal integer in the range of 0 to 65535, where the default value is 23. If *[debug]* is used, the current telnet options enabled is displayed. The optional *line* parameter sets the outbound telnet operational mode as 'linemode', where by default, the operational mode is 'character mode'. The *noecho* option disables local echo.

Format `telnet <host> [port] [debug] [line] [noecho]`

Modes Privileged EXEC User EXEC

7.2.2 *transport input telnet*

This command regulates new telnet sessions. If sessions are enabled, new telnet sessions can be established until there are no more sessions available. If sessions are disabled, no new telnet sessions are established. An established session remains active until the session is ended or an abnormal network error ends the session.

Default enabled

Format `transport input telnet`

Mode Line Config

7.2.2.1 *no transport input telnet*

This command disables telnet sessions. If sessions are disabled, no new telnet sessions are established.

Format `no transport input telnet`**Mode** Line Config

7.2.3 *transport output telnet*

This command regulates new outbound telnet connections. If enabled, new outbound telnet sessions can be established until it reaches the maximum number of simultaneous outbound telnet sessions allowed. If disabled, no new outbound telnet session can be established. An established session remains active until the session is ended or an abnormal network error ends it.

Default enabled

Format `transport output telnet`

Mode Line Config

7.2.3.1 no transport output telnet

This command disables new outbound telnet connections. If disabled, no new outbound telnet connection can be established.

Format no transport output telnet

Mode Line Config

7.2.4 session-limit

This command specifies the maximum number of simultaneous outbound telnet sessions. A value of 0 indicates that no outbound telnet session can be established.

Default 5

Format session-limit <0-5>

Mode Line Config

7.2.4.1 no session-limit

This command sets the maximum number of simultaneous outbound telnet sessions to the default value.

Format no session-limit **Mode** Line Config

7.2.5 session-timeout

This command sets the outbound telnet session timeout value. The timeout value unit of time is minutes. A value of 0 indicates that a session remains active indefinitely.

Default 0

Format session-timeout <0-160>

Mode Line Config

7.2.5.1 no session-timeout

This command sets the outbound telnet session timeout value to the default. The timeout value unit of time is minutes.

Format no session-timeout

Mode Line Config

7.2.6 bridge aging-time

This command configures the forwarding database address aging timeout in seconds. In an IVL system, the [fdbid | all] parameter is required.

Default 300

Format bridge aging-time <10-1,000,000> [fdbid | all]

Mode Global Config **Seconds** The <seconds> parameter must be within the range of 10 to 1,000,000 seconds.

Forwarding Database ID Fdbid (Forwarding database ID) indicates which forwarding database's aging timeout is being configured. The All option is used to configure all forwarding database's aging time.

7.2.6.1 no bridge aging-time

This command sets the forwarding database address aging timeout to 300 seconds. In an IVL system, the [fdbid | all] parameter is required.

Format no bridge aging-time [fdbid | all]

Mode Global Config **Forwarding Database ID**

Fdbid (Forwarding database ID) indicates which forwarding database's aging timeout is being configured. All is used to configure all forwarding database's aging time.

7.2.7 mtu

This command sets the maximum transmission unit (MTU) size (in bytes) for physical and port-channel (LAG) interfaces. For the standard implementation, the range of <mtusize> is a valid integer between 1522 - 9216 for tagged packets and a valid interger between 1518 - 1926 for untagged packets.

Note: To receive and process packets, the Ethernet MTU must include any extra bytes that may be required for Layer-2 headers. Whereaa, the IP MTU size (See "ip mtu" on page 183.) refers to the maximum size of the IP packet (IP Header + IP payload).

Default 1522 (*tagged*)

1518 (*untagged*)

Format mtu <1522-9216>

Mode Interface Config

7.2.7.1 no mtu

This command sets the default maximum transmission unit (MTU) size (in bytes) for the interface.

Format no mtu

Mode Interface Config

7.2.8 network javamode

This command specifies whether or not the switch should allow access to the Java applet in the header frame of the Web interface. When access is enabled, the Java applet can be viewed from the Web interface. When access is disabled, the user cannot view the Java applet.

Default enabled

Format network javamode

Mode Privileged EXEC

7.2.8.1 *no network javamode*

This command disallows access to the Java applet in the header frame of the Web interface. When access is disabled, the user cannot view the Java applet.

Format `no network javamode`

Mode Privileged EXEC

7.2.9 *network mac-address*

This command sets locally administered MAC addresses. The following rules apply:

- Bit 6 of byte 0 (called the U/L bit) indicates whether the address is universally administered (b'0') or locally administered (b'1').
- Bit 7 of byte 0 (called the I/G bit) indicates whether the destination address is an individual address (b'0') or a group address (b'1').
- The second character, of the twelve character macaddr, must be 2, 6, A or E.

A locally administered address must have bit 6 On (b'1') and bit 7 Off (b'0').

Format `network mac-address <macaddr>`

Mode Privileged EXEC

7.2.10 *network mac-type*

This command specifies whether the burned in MAC address or the locally-administered MAC address is used.

Default burned-in

Format `network mac-type {local | burnedin}`

Mode Privileged EXEC

7.2.10.1 *no network mac-type*

This command resets the value of MAC address to its default.

Format `no network mac-type`

Mode Privileged EXEC

7.2.11 *network parms*

This command sets the IP Address, subnet mask and gateway of the router. The IP Address and the gateway must be on the same subnet.

Format `network parms <ipaddr> <netmask> [<gateway>]`

Mode Privileged EXEC

7.2.12 network protocol

This command specifies the network configuration protocol to be used. If you modify this value change is effective immediately. The parameter **bootp** indicates that the switch periodically sends requests to a Bootstrap Protocol (BootP) server or a dhcp server until a response is received. **none** indicates that the switch should be manually configured with IP information.

Default none

Format network protocol {none | bootp | dhcp}

Mode Privileged EXEC

7.2.13 telnetcon maxsessions

This command specifies the maximum number of telnet connection sessions that can be established. A value of 0 indicates that no telnet connection can be established. The range is 0 to 5.

Default 5

Format telnetcon maxsessions <0-5>

Mode Privileged EXEC

7.2.13.1 no telnetcon maxsessions

This command sets the maximum number of telnet connection sessions that can be established to the default value.

Format no telnetcon maxsessions

Mode Privileged EXEC

7.2.14 telnetcon timeout

This command sets the telnet connection session timeout value, in minutes. A session is active as long as the session has not been idle for the value set. The time is a decimal value from 1 to 160.

Note: Changing the timeout value for active sessions does not become effective until the session is reaccessed. Also, any keystroke activates the new timeout duration.

Default 5

Format telnetcon timeout <1-160>

Mode Privileged EXEC

7.2.14.1 no telnetcon timeout

This command sets the telnet connection session timeout value to the default.

Note: Changing the timeout value for active sessions does not become effective until the session is reaccessed. Also, any keystroke activates the new timeout duration.

Format no telnetcon timeout

Mode Privileged EXEC

7.2.15 serial baudrate

This command specifies the communication rate of the terminal interface. The supported rates are 1200, 2400, 4800, 9600, 19200, 38400, 57600, 115200.

Default 9600

Format serial baudrate {1200 | 2400 | 4800 | 9600 | 19200 | 38400 | 57600 | 115200}

Mode Line Config

7.2.15.1 no serial baudrate

This command sets the communication rate of the terminal interface.

Format no serial baudrate

Mode Line Config

7.2.16 serial timeout

This command specifies the maximum connect time (in minutes) without console activity. A value of 0 indicates that a console can be connected indefinitely. The time range is 0 to 160.

Default 5

Format serial timeout <0-160>

Mode Line Config

7.2.16.1 no serial timeout

This command sets the maximum connect time (in minutes) without console activity.

Format no serial timeout

Mode Line Config

7.2.17 set prompt

This command changes the name of the prompt. The length of name may be up to 64 alphanumeric characters.

Format set prompt <prompt string>

Mode Privileged EXEC

7.2.18 *show telnet*

This command displays the current outbound telnet settings.

Format `show telnet`

Modes Privileged EXEC User EXEC

Outbound Telnet Login Timeout (in minutes) Indicates the number of minutes an outbound telnet session is allowed to remain inactive before being logged off. A value of 0, which is the default, results in no timeout.

Maximum Number of Outbound Telnet Sessions Indicates the number of simultaneous outbound telnet connections allowed.

Allow New Outbound Telnet Sessions Indicates whether outbound telnet sessions will be allowed.

7.2.19 *show forwardingdb agetime*

This command displays the timeout for address aging. In an IVL system, the `[fdbid | all]` parameter is required.

Default all

Format `show forwardingdb agetime [fdbid | all]`

Mode Privileged EXEC

Forwarding DB ID `Fdbid` (Forwarding database ID) indicates the forwarding database whose aging timeout is to be shown. The `all` option is used to display the aging timeouts associated with all forwarding databases. This field displays the forwarding database ID in an IVL system.

Agetime In an IVL system, this parameter displays the address aging timeout for the associated forwarding database.

7.2.20 *show network*

This command displays configuration settings associated with the switch's network interface. The network interface is the logical interface used for in-band connectivity with the switch via any of the switch's front panel ports. The configuration parameters associated with the switch's network interface do not affect the configuration of the front panel ports through which traffic is switched or routed.

Format `show network`

Mode Privileged EXEC and User EXEC

IP Address The IP address of the interface. The factory default value is 0.0.0.0

Subnet Mask The IP subnet mask for this interface. The factory default value is 0.0.0.0

Default Gateway The default gateway for this IP interface. The factory default value is 0.0.0.0

Burned In MAC Address The burned in MAC address used for in-band connectivity.

Locally Administered MAC Address If desired, a locally administered MAC address can be configured for in-band connectivity. To take effect, 'MAC Address Type' must be set to 'Locally

Administered'. Enter the address as twelve hexadecimal digits (6 bytes) with a colon between each byte. Bit 1 of byte 0 must be set to a 1 and bit 0 to a 0, i.e. byte 0 should have the following mask 'xxxx xx10'. The MAC address used by this bridge when it must be referred to in a unique fashion. It is recommended that this be the numerically smallest MAC address of all ports that belong to this bridge. However it is only required to be unique. When concatenated with dot1dStpPriority a unique Bridge Identifier is formed which is used in the Spanning Tree Protocol.

MAC Address Type Specifies which MAC address should be used for in-band connectivity. The choices are the burned in or the Locally Administered address. The factory default is to use the burned in MAC address.

Network Configuration Protocol Current Indicates which network protocol is being used. The options are bootp | dhcp | none.

Java Mode Specifies if the switch should allow access to the Java applet in the header frame. Enabled means the applet can be viewed. The factory default is disabled.

Management VLAN ID Specifies the management VLAN ID.

7.2.21 *show telnetcon*

This command displays telnet settings.

Format `show telnetcon`

Mode `Privileged EXEC and User EXEC`

Remote Connection Login Timeout (minutes) This object indicates the number of minutes a remote connection session is allowed to remain inactive before being logged off. A zero means there will be no timeout. May be specified as a number from 0 to 160. The factory default is 5.

Maximum Number of Remote Connection Sessions This object indicates the number of simultaneous remote connection sessions allowed. The factory default is 5.

Allow New Telnet Sessions Indicates that new telnet sessions will not be allowed when set to no. The factory default value is yes.

7.2.22 *show serial*

This command displays serial communication settings for the switch.

Format `show serial`

Mode `Privileged EXEC and User EXEC`

Serial Port Login Timeout (minutes) Specifies the time, in minutes, of inactivity on a Serial port connection, after which the Switch will close the connection. Any numeric value between 0 and 160 is allowed, the factory default is 5. A value of 0 disables the time-out.

Baud Rate The default baud rate at which the serial port will try to connect. The available values are 1200, 2400, 4800, 9600, 19200, 38400, 57600, and 115200 baud. The factory Default is 9600 baud.

Character Size The number of bits in a character. The number of bits is always 8.

Flow Control Whether Hardware Flow-Control is enabled or disabled. Hardware Flow Control is always disabled.

Stop Bits The number of Stop bits per character. The number of Stop bits is always 1.

Parity Type The Parity Method used on the Serial Port. The Parity Method is always None.

7.2.23 single_ip_mgmt enable (only for Layer 2 Series)

This command enables the single IP management function. It allows the network administrator to configure multiple switch using the same IP address, while use the group-id and switch-id to identify for each of them.

Format single_ip_mgmt enable

Mode Privileged EXEC

7.2.24 single_ip_mgmt groupid (only for Layer 2 Series)

This command sets the group ID for single IP management function.

Format single_ip_mgmt groupid <1-250>

Mode Privileged EXEC

7.2.25 single_ip_mgmt mastered (only for Layer 2 Series)

This command sets the master ID for single IP management function.

Format single_ip_mgmt master <1-250>

Mode Privileged EXEC

7.2.26 single_ip_mgmt network_parms (only for Layer 2 Series)

This command sets the network parameters for single IP management function.

Format single_ip_mgmt network_parms <ipaddr> <netmask> [<gateway>]

Mode Privileged EXEC

7.2.27 single_ip_mgmt switched (only for Layer 2 Series)

This command sets the switch id for single IP management function.

Format single_ip_mgmt switchid

Mode Privileged EXEC

7.2.28 *show single_ip_mgmt (only for Layer 2 Series)*

This command displays the single ip management configuration information. This function allows you to use the same IP to configure multiple switches, while identify the different devices with the configurable group ID and switch ID.

Format show single_ip_mgmt

Mode Privileged EXEC

Single Ip Management Enable/Disable this function.

Single Ip Mgmt Group Id The group ID of the switch.

Single Ip Mgmt Switch Id The ID of the switch.

Single Ip Mgmt Ip Address The IP of the switch.

Single Ip Mgmt Networkmask The network mask of the switch.

Single Ip Mgmt Gateway The default gateway of the switch.

Single Ip Mgmt Group Members List the member of the group.

This switch is a master switch Describe if the switch is a master or not.

Client Switch Id(s) Describe the Client Switch IDs.

7.3 SNMP Community Commands

7.3.1 *show snmpcommunity*

This command displays SNMP community information. Six communities are supported. You can add, change, or delete communities. The switch does not have to be reset for changes to take effect.

The SNMP agent of the switch complies with SNMP Version 1 (for more about the SNMP specification, see the SNMP RFCs). The SNMP agent sends traps through TCP/IP to an external SNMP manager based on the SNMP configuration (the trap receiver and other SNMP community parameters).

Format `show snmpcommunity`

Mode Privileged EXEC

SNMP Community Name The community string to which this entry grants access. A valid entry is a case-sensitive alphanumeric string of up to 16 characters. Each row of this table must contain a unique community name.

Client IP Address - An IP address (or portion thereof) from which this device will accept SNMP packets with the associated community. The requesting entity's IP address is ANDed with the Subnet Mask before being compared to the IP Address. Note: that if the Sub-net Mask is set to 0.0.0.0, an IP Address of 0.0.0.0 matches all IP addresses. The default value is 0.0.0.0

Client IP Mask -A mask to be ANDed with the requesting entity's IP address before comparison with IP Address. If the result matches with IP Address then the address is an authenticated IP address. For example, if the IP Address = 9.47.128.0 and the corresponding Subnet Mask = 255.255.255.0 a range of incoming IP addresses would match, i.e. the incoming IP Address could equal 9.47.128.0 - 9.47.128.255. The default value is 0.0.0.0.

Access Mode The access level for this community string.

Status The status of this community access entry.

7.3.2 *show snmptrap*

This command displays SNMP trap receivers. Trap messages are sent across a network to an SNMP Network Manager. These messages alert the manager to events occurring within the switch or on the network. Six trap receivers are simultaneously supported.

Format `show snmptrap`

Mode Privileged EXEC

SNMP Trap Name The community string of the SNMP trap packet sent to the trap manager. This may be up to 16 alphanumeric characters. This string is case sensitive.

IP Address The IP address to receive SNMP traps from this device. Enter four numbers between 0 and 255 separated by periods.

Status Indicates the receiver's status (enabled or disabled).

7.3.3 *show trapflags*

This command displays trap conditions. Configure which traps the switch should generate by enabling or disabling the trap condition. If a trap condition is enabled and the condition is detected, the switch's SNMP agent sends the trap to all enabled trap receivers. The switch does not have to be reset to implement the changes. Cold and warm start traps are always generated and cannot be disabled.

Format `show trapflags`

Mode Privileged EXEC

Authentication Flag May be enabled or disabled. The factory default is enabled. Indicates whether authentication failure traps will be sent.

Link Up/Down Flag May be enabled or disabled. The factory default is enabled. Indicates whether link status traps will be sent.

Multiple Users Flag May be enabled or disabled. The factory default is enabled. Indicates whether a trap will be sent when the same user ID is logged into the switch more than once at the same time (either via telnet or serial port).

Spanning Tree Flag May be enabled or disabled. The factory default is enabled. Indicates whether spanning tree traps will be sent.

Broadcast Storm Flag May be enabled or disabled. The factory default is enabled. Indicates whether broadcast storm traps will be sent.

DVMRP Traps May be enabled or disabled. The factory default is disabled. Indicates whether DVMRP traps will be sent.

OSPF Traps May be enabled or disabled. The factory default is disabled. Indicates whether OSPF traps will be sent.

PIM Traps May be enabled or disabled. The factory default is disabled. Indicates whether PIM traps will be sent.

7.3.4 *snmp-server community*

This command adds (and names) a new SNMP community. A community name is a name associated with the switch and with a set of SNMP managers that manage it with a specified privileged level. The length of name can be up to 16 case-sensitive characters.

Note: Community names in the SNMP community table must be unique. When making multiple entries using the same community name, the first entry is kept and processed and all duplicate entries are ignored.

Default Two default community names: Public and Private. You can replace these default community names with unique identifiers for each community. The default values for the remaining four community names are blank.

Format `snmp-server community <name>`

Mode Global Config

7.3.4.1 *no snmp-server community*

This command removes this community name from the table. The name is the community name to be deleted.

Format no snmp-server community <name>

Mode Global Config

7.3.5 *snmp-server community ipaddr*

This command sets a client IP address for an SNMP community. The address is the associated community SNMP packet sending address and is used along with the client IP mask value to denote a range of IP addresses from which SNMP clients may use that community to access the device. A value of 0.0.0.0 allows access from any IP address. Otherwise, this value is ANDed with the mask to determine the range of allowed client IP addresses. The name is the applicable community name.

Default 0.0.0.0

Format snmp-server community ipaddr <ipaddr> <name>

Mode Global Config

7.3.5.1 *no snmp-server community ipaddr*

This command sets a client IP address for an SNMP community to **0.0.0.0**. The name is the applicable community name.

Format no snmp-server community ipaddr <name>

Mode Global Config

7.3.6 *snmp-server community ipmask*

This command sets a client IP mask for an SNMP community. The address is the associated community SNMP packet sending address and is used along with the client IP address value to denote a range of IP addresses from which SNMP clients may use that community to access the device. A value of 255.255.255.255 will allow access from only one station, and will use that machine's IP address for the client IP Address. A value of 0.0.0.0 will allow access from any IP address. The name is the applicable community name.

Default 0.0.0.0

Format snmp-server community ipmask <ipmask> <name>

Mode Global Config

7.3.6.1 *no snmp-server community ipmask*

This command sets a client IP mask for an SNMP community to **0.0.0.0**. The name is the

applicable community name. The community name may be up to 16 alphanumeric characters.

Format no snmp-server community ipmask <name>

Mode Global Config

7.3.7 snmp-server community mode

This command activates an SNMP community. If a community is enabled, an SNMP manager associated with this community manages the switch according to its access right. If the community is disabled, no SNMP requests using this community are accepted. In this case the SNMP manager associated with this community cannot manage the switch until the Status is changed back to Enable.

Default The default private and public communities are enabled by default. The four undefined communities are disabled by default.

Format snmp-server community mode <name>

Mode Global Config

7.3.7.1 no snmp-server community mode

This command deactivates an SNMP community. If the community is disabled, no SNMP requests using this community are accepted. In this case the SNMP manager associated with this community cannot manage the switch until the Status is changed back to Enable.

Format no snmp-server community mode <name>

Mode Global Config

7.3.8 snmp-server community ro

This command restricts access to switch information. The access mode is read-only (also called public).

Format snmp-server community ro <name>

Mode Global Config

7.3.9 snmp-server community rw

This command restricts access to switch information. The access mode is read/write (also called private).

Format snmp-server community rw <name>

Mode Global Config

7.3.10 snmp-server enable traps

This command enables the Authentication Flag.

Default enabled

Format snmp-server enable traps

Mode Global Config

7.3.10.1 no snmp-server enable traps

This command disables the Authentication Flag.

Format no snmp-server enable traps

Mode Global Config

7.3.11 snmp-server enable traps bcaststorm

This command enables the broadcast storm trap. When enabled, broadcast storm traps are sent only if the broadcast storm recovery mode setting associated with the port is enabled.

Default enabled

Format snmp-server enable traps bcaststorm

Mode Global Config

7.3.11.1 no snmp-server enable traps bcaststorm

This command disables the broadcast storm trap. When enabled, broadcast storm traps are sent only if the broadcast storm recovery mode setting associated with the port is enabled .

Format no snmp-server enable traps bcaststorm

Mode Global Config

7.3.12 snmp-server enable traps linkmode

This command enables Link Up/Down traps for the entire switch. When enabled, link traps are sent only if the Link Trap flag setting associated with the port is enabled (see 'snmp trap link-status' command).

Default enabled

Format snmp-server enable traps linkmode

Mode Global Config

7.3.12.1 no snmp-server enable traps linkmode

This command disables Link Up/Down traps for the entire switch.

Format no snmp-server enable traps linkmode

Mode Global Config

7.3.13 snmp-server enable traps multiusers

This command enables Multiple User traps. When the traps are enabled, a Multiple User Trap is sent when a user logs in to the terminal interface (EIA 232 or telnet) and there is an existing terminal interface session.

Default enabled

Format snmp-server enable traps multiusers

Mode Global Config

7.3.13.1 no snmp-server enable traps multiusers

This command disables Multiple User traps.

Format no snmp-server enable traps multiusers

Mode Global Config

7.3.14 snmp-server enable traps stpmode

This command enables the sending of new root traps and topology change notification traps.

Default enabled

Format snmp-server enable traps stpmode

Mode Global Config

7.3.14.1 no snmp-server enable traps stpmode

This command disables the sending of new root traps and topology change notification traps.

Format no snmp-server enable traps stpmode

Mode Global Config

5.3.15 snmptrap

This command adds an SNMP trap name. The maximum length of name is 16 case-sensitive alphanumeric characters.

Default The default name for the six undefined community names is Delete.

Format snmptrap <name> <ipaddr>

Mode Global Config

7.3.15.1 no snmptrap

This command deletes trap receivers for a community.

Format no snmptrap <name> <ipaddr>

Mode Global Config

7.3.16 snmptrap ipaddr

This command assigns an IP address to a specified community name. The maximum length of name is 16 case-sensitive alphanumeric characters.

Note: IP addresses in the SNMP trap receiver table must be unique. If you make multiple entries using the same IP address, the first entry is retained and processed. All duplicate entries are ignored.

Format snmptrap ipaddr <name> <ipaddrold> <ipaddrnew>

Mode Global Config

7.3.17 snmptrap mode

This command activates or deactivates an SNMP trap. Enabled trap receivers are active (able to receive traps). Disabled trap receivers are inactive (not able to receive traps).

Format snmptrap mode <name> <ipaddr>

Mode Global Config

7.3.17.1 no snmptrap mode

This command deactivates an SNMP trap. Disabled trap receivers are inactive (not able to receive traps).

Format no snmptrap mode <name> <ipaddr>

Mode Global Config

7.3.18 snmp trap link-status

This command enables link status traps by interface.

Note: This command is valid only when the Link Up/Down Flag is enabled. See 'snmp-server enable traps linkmode' command.

Format snmp trap link-status

Mode Interface Config

7.3.18.1 no snmp trap link-status

This command disables link status traps by interface.

Note: This command is valid only when the Link Up/Down Flag is enabled. See 'snmp-server enable traps linkmode' command).

Format no snmp trap link-status

Mode Interface Config

7.3.19 snmp trap link-status all

This command enables link status traps for all interfaces.

Note: *This command is valid only when the Link Up/Down Flag is enabled (see “snmp-server enable traps linkmode”).*

Format snmp trap link-status all

Mode Global Config

7.3.19.1 no snmp trap link-status all

This command disables link status traps for all interfaces.

Note: *This command is valid only when the Link Up/Down Flag is enabled (see “snmp-server enable traps linkmode”).*

Format no snmp trap link-status all

Mode Global Config

7.3.20 snmptrap snmpversion

This command configures SNMP trapversion for a specified community.

Format snmptrap snmpversion

Mode Global Config

7.4 Management VLAN Command

This command is used to set the Management VLAN.

7.4.1 *network mgmt_vlan*

This command configures the Management VLAN ID.

Default 1

Format `network mgmt_vlan <1-4094>`

Mode Privileged EXEC

7.5 System Configuration Commands

This chapter provides a detailed explanation of the System configuration commands. The commands are divided into two functional groups:

- Show commands display switch settings, statistics, and other information.
- Configuration commands configure features and options of the switch. For every configuration command, there is a show command that displays the configuration setting.

7.5.1 *addport*

This command adds one port to the port-channel (LAG). The first interface is a logical unit, slot and port number of a configured port-channel.

Note: Before adding a port to a port-channel, set the physical mode of the port. See 'speed' command.

Format addport <logical unit/slot/port>

Mode Interface Config

7.5.2 *cablestatus*

This command tests the status of the cable attached to an interface.

Format cablestatus <unit/slot/port>

Mode Privileged EXEC

7.5.3 *auto-negotiate*

This command enables automatic negotiation on a port. The default value is enable.

Format auto-negotiate

Mode Interface Config

7.5.3.1 *no auto-negotiate*

This command disables automatic negotiation on a port.

Note: Automatic sensing is disabled when automatic negotiation is disabled.

Format no auto-negotiate

Mode Interface Config

7.5.4 *auto-negotiate all*

This command enables automatic negotiation on all ports. The default value is enable.

Format auto-negotiate all

Mode Global Config

7.5.4.1 no auto-negotiate all

This command disables automatic negotiation on all ports.

Format no auto-negotiate all

Mode Global Config

7.5.5 deleteport (Interface Config)

This command deletes the port from the port-channel (LAG). The interface is a logical unit, slot and port slot and port number of a configured port-channel.

Format deleteport <logical unit/slot/port>

Mode Interface Config

7.5.6 deleteport (Global Config)

This command deletes all configured ports from the port-channel (LAG). The interface is a logical unit, slot and port slot and port number of a configured port-channel.

Format deleteport {<logical unit/slot/port> | all}

Mode Global Config

7.5.7 monitor session mode

This command configures the monitor session (port monitoring) mode to enable. The probe and monitored ports must be configured before monitor session (port monitoring) can be enabled. If enabled, the probe port will monitor all traffic received and transmitted on the physical monitored port. It is not necessary to disable port monitoring before modifying the probe and monitored ports.

A session is operationally active if and only if both a destination port and at least one source port is configured. If neither is true, the session is inactive.

A port configured as a destination port acts as a mirroring port when the session is operationally active. If it is not, the port acts as a normal port and participates in all normal operation with respect to transmitting traffic.

Default disabled

Format monitor session mode

Mode Global Config

7.5.7.1 no monitor session mode

This command sets the monitor session (port monitoring) mode to disable.

Format no monitor session mode

Mode Global Config

7.5.8 *monitor session 1 source interface*

This command adds a mirrored port (source port) to a session identified with <session-id>.

Note: The <session-id> parameter is an integer value used to identify the session. In the current version of the software, the <session-id> parameter is always 1.

Default None

Format monitor session <session-id> source interface <unit/slot/port>

Mode Global config

7.5.8.1 *no monitor session 1 source interface*

This command removes the specified mirrored port (source port) from the session.

Note: The <session-id> parameter is an integer value used to identify the session. In the current version of the software, the <session-id> parameter is always 1.

Format no monitor session <session-id> source interface <unit/slot/port>

Mode Global config

7.5.9 *shutdown*

This command disables a port.

Default enabled

Format shutdown

Mode Interface Config

7.5.9.1 *no shutdown*

This command enables a port.

Format no shutdown

Mode Interface Config

7.5.10 *shutdown all*

This command disables all ports.

Default enabled

Format shutdown all

Mode Global Config

7.5.10.1 *no shutdown all*

This command enables all ports.

Format no shutdown all

Mode Global Config

7.5.11 *speed*

This command sets the speed and duplex setting for the interface.

Format speed {<100 | 10> <half-duplex | full-duplex>}

Mode Interface Config

Acceptable values are:

100h 100BASE-T half duplex

100f 100BASE-T full duplex

10h 10BASE-T half duplex

10f 10BASE-T full duplex

7.5.12 *speed all*

This command sets the speed and duplex setting for all interfaces.

Format speed all {<100 | 10> <half-duplex | full-duplex>}

Mode Global Config

Acceptable values are:

100h 100BASE-T half-duplex

100f 100BASE-T full duplex

10h 10BASE-T half duplex

10f 10BASE-T full duplex

7.5.13 *switchport protected all*

This command sets protected mode for all interfaces.

Format switch protected all
Mode Global Config

7.5.13.1 *no switchport protected all*

This command disables the protect mode for all interfaces.

Format no switchport protected all
Mode Global Config

7.5.14 *switchport protected*

This command enables protected mode for the interface.

Format switchport protected
Modes Interface Config

7.5.14.1 *no switchport protected*

This command disables protected mode for the interface.

Format no switchport protected
Modes Interface Config

7.5.15 *storm-control broadcast*

This command enables broadcast storm recovery mode. If the mode is enabled, broadcast storm recovery with high and low thresholds is implemented.

The threshold implementation follows a percentage pattern. If the broadcast traffic on any Ethernet port exceeds the high threshold percentage (as represented in “Broadcast Storm Recovery Thresholds” table) of the link speed, the switch discards the broadcasts traffic until the broadcast traffic returns to the low threshold percentage or less. The full implementation is depicted in the “Broadcast Storm Recovery Thresholds” table.

Table 11. Broadcast Storm Recovery Thresholds

Link Speed	High	Low
10M	20	10
100M	5	2
1000M	5	2

Format storm-control broadcast

Mode Global Config

7.5.15.1 no storm-control broadcast

This command disables broadcast storm recovery mode.

The threshold implementation follows a percentage pattern. If the broadcast traffic on any Ethernet port exceeds the high threshold percentage (as represented in “Broadcast Storm Recovery Thresholds” table) of the link speed, the switch discards the broadcasts traffic until the broadcast traffic returns to the low threshold percentage or less. The full implementation is depicted in the “Broadcast Storm Recovery Thresholds” table.

Table 12. Broadcast Storm Recovery Thresholds

Link Speed	High	Low
10M	20	10
100M	5	2
1000M	5	2

Format no storm-control broadcast

Mode Global Config

7.5.16 storm-control flowcontrol

This command enables 802.3x flow control for the switch.

Note: 802.3x flow control works by pausing a port when the port becomes oversubscribed and dropping all traffic for small bursts of time during the congestion condition. This can lead to high-priority and/or network control traffic loss.

Note: This command only applies to full-duplex mode ports.

Default disabled

Format storm-control flowcontrol

Mode Global Config

7.5.16.1 no storm-control flowcontrol

This command disables 802.3x flow control for the switch.

Note: This command only applies to full-duplex mode ports.

Format no storm-control flowcontrol

Mode Global Config

7.5.17 storm-control action shutdown

This command shutdowns the interface.

Format storm-control action shutdown

Mode interface config

7.5.18 storm-control action trap

This command generates a trap when storm occurs.

Format storm-control action trap

Mode interface config

7.5.19 storm-control action trap-shotdown

This command shutdowns and generates a trap when storm occurs.

Format storm-control action trap-shotdown

Mode interface config

7.5.20 storm-control mode broadcast

This command enables broadcast storm-control feature.

Format storm-control mode broadcast

Mode interface config

7.5.20.1 no storm-control mode broadcast

This command disables broadcast storm-control feature.

Format no storm-control mode broadcast

Mode interface config

7.5.21 storm-control mode multicast

This command enables multicast storm-control feature.

Format storm-control mode multicast

Mode interface config

7.5.21.1 no storm-control mode multicast

This command disables multicast storm-control feature.

Format no storm-control mode multicast

Mode interface config

7.5.22 storm-control mode unicast

This command enables unicast storm-control feature.

Format storm-control mode unicast

Mode interface config

7.5.22.1 no storm-control mode unicast

This command disables unicast storm-control feature.

Format no storm-control mode unicast

Mode interface config

7.5.23 storm-control level

This command configures the threshold level.

Format storm-control level <level>

Mode interface config

7.5.24 storm-control recovery-time

This command sets the recovery time for storm control.

Format storm control recovery-time <time>

Mode Privileged EXEC

7.5.25 show mac-address-table multicast

This command displays the Multicast Forwarding Database (MFDB) information. If the command is entered with no parameter, the entire table is displayed. This is the same as entering the optional *all* parameter. The user can display the table entry for one MAC Address by specifying the MAC address as an optional parameter.

Format show mac-address-table multicast <macaddr | all>

Mode Privileged EXEC

Mac Address A multicast MAC address for which the switch has forwarding and or filtering information. The format is two-digit hexadecimal numbers that are separated by colons, for example 01:23:45:67:89:AB. In an IVL system the MAC address will be displayed as a MAC address and VLAN ID combination of 8 bytes.

Type This displays the type of the entry. Static entries are those that are configured by the end user. Dynamic entries are added to the table as a result of a learning process or protocol.

Component The component that is responsible for this entry in the Multicast Forwarding Database. Possible values are IGMP Snooping, GMRP, and Static Filtering.

Description The text description of this multicast table entry.

Interfaces The list of interfaces that are designated for forwarding (Fwd:) and filtering (Flt:).

Forwarding Interfaces The resultant forwarding list is derived from combining all the component's forwarding interfaces and removing the interfaces that are listed as the static filtering interfaces.

7.5.26 *show mac-address-table static*

This command displays the Static MAC Filtering information for all Static MAC Filters. If <all> is selected, all the Static MAC Filters in the system are displayed. If a macaddr is entered, a vlan must also be entered and the Static MAC Filter information will be displayed only for that MAC address and VLAN.

Format `show mac-address-table static {<macaddr> <vlanid> | all}`

Mode Privileged EXEC

MAC Address Is the MAC Address of the static MAC filter entry.

VLAN ID Is the VLAN ID of the static MAC filter entry.

Source Port(s) Indicates the source port filter set's slot and port(s).

Destination Port(s) Indicates the destination port filter set's slot and port(s).

7.5.27 *show mac-address-table stats*

This command displays the Multicast Forwarding Database (MFDB) statistics.

Format `show mac-address-table stats`

Mode Privileged EXEC

Total Entries This displays the total number of entries that can possibly be in the Multicast Forwarding Database table.

Most MFDB Entries Ever Used This displays the largest number of entries that have been present in the Multicast Forwarding Database table. This value is also known as the MFDB high-water mark.

Current Entries This displays the current number of entries in the Multicast Forwarding Database table.

7.5.28 *show monitor session*

This command displays the Port monitoring information for a particular mirroring session.

Note: The <session-id> parameter is an integer value used to identify the session. In the current version of the software, the <session-id> parameter is always 1.

Format `show monitor session <session-id>`

Mode Privileged EXEC

The following is the explanation of the output parameters for this command:

Session ID It is an integer value used to identify the session. Its value can be anything between 1 and L7_MIRRORING_MAX_SESSIONS.

Monitor Session Mode It indicates whether the Port Mirroring feature is enabled or disabled for the session identified with <session-id>. The possible values are Enabled and Disabled.

Probe Port It is the probe port (destination port) for the session identified with <session-id>. If probe port is not set then this field is blank.

List of source Ports It is the list of ports, which are configured as mirrored ports (source ports) for the session identified with <session-id>. If no source port is configured for the session then this field is blank.

7.5.29 *show port*

This command displays port information.

Format `show port {<unit/slot/port> / all}`

Mode Privileged EXEC

Unit/Slot/Port Valid unit, slot and port number separated by forward slashes.

Type If not blank, this field indicates that this port is a special type of port. The possible values are:

Mon - this port is a monitoring port. Look at the Port Monitoring screens to find out more information.

Lag - this port is a member of a port-channel (LAG).

Probe - this port is a probe port.

Admin Mode Selects the Port control administration state. The port must be enabled in order for it to be allowed into the network. - May be enabled or disabled. The factory default is enabled.

Physical Mode Selects the desired port speed and duplex mode. If auto-negotiation support is selected, then the duplex mode and speed will be set from the auto-negotiation process. Note that the port's maximum capability (full duplex -100M) will be advertised. Otherwise, this object will determine the port's duplex mode and transmission rate. The factory default is Auto.

Physical Status Indicates the port speed and duplex mode.

Link Status Indicates whether the Link is up or down.

Link Trap This object determines whether or not to send a trap when link status changes. The factory default is enabled.

LACP Mode Displays whether LACP is enabled or disabled on this port.

7.5.30 show port protocol

This command displays the Protocol-Based VLAN information for either the entire system, or for the indicated Group.

Format `show port protocol <groupid / all>`

Mode Privileged EXEC

Group Name This field displays the group name of an entry in the Protocol-based VLAN table.

Group ID This field displays the group identifier of the protocol group.

Protocol(s) This field indicates the type of protocol(s) for this group.

VLAN This field indicates the VLAN associated with this Protocol Group.

Interface(s) This field lists the unit/slot/port interface(s) that are associated with this Protocol Group.

7.5.31 show storm-control

This command displays switch configuration information.

Format `show storm-control`

Mode Privileged EXEC

Broadcast Storm Recovery Mode May be enabled or disabled. The factory default is disabled.

802.3x Flow Control Mode May be enabled or disabled. The factory default is disabled.

7.5.32 show interface protected

This command displays the protected port configuration.

Format `port-security allow`

Modes Privileged EXEC

7.6 Virtual LAN (VLAN) Commands

7.6.1 *vlanset*

This command is a batch command to set VLAN for multi-ports. For example, we have command executed below,

```
vlanset 0/1 - 0/9 tagged basevid 3 vlantrunk 0/5
```

it means, total have 9 vlans been created, and starts from vid 3, each vlan has two tagged member ports, please see below,

```
vid 3 = 0/1, 0/5 (both ports are tagged ports, 0/5 is vlantrunk port)
vid 4 = 0/2, 0/5 (both ports are tagged ports, 0/5 is vlantrunk port)
vid 5 = 0/3, 0/5 (both ports are tagged ports, 0/5 is vlantrunk port)
vid 6 = 0/4, 0/5 (both ports are tagged ports, 0/5 is vlantrunk port)
vid 7 = 0/5, 0/5 (both ports are tagged ports, 0/5 is vlantrunk port)
vid 8 = 0/6, 0/5 (both ports are tagged ports, 0/5 is vlantrunk port)
vid 9 = 0/7, 0/5 (both ports are tagged ports, 0/5 is vlantrunk port)
vid 10 = 0/8, 0/5 (both ports are tagged ports, 0/5 is vlantrunk port)
vid 11 = 0/9, 0/5 (both ports are tagged ports, 0/5 is vlantrunk port)
```

Format `vlanset <slot/port> - <slot/port> {tagged|untagged} basepvid <1-4093> vlantrunk <slot/port>`

Mode Global Config

7.6.2 *vlan*

This command creates a new VLAN and assigns it an ID. The ID is a valid VLAN identification number (ID 1 is reserved for the default VLAN). VLAN range is 2-4094.

Format `vlan <2-4094>`

Mode VLAN database

7.6.2.1 *no vlan*

This command deletes an existing VLAN. The ID is a valid VLAN identification number (ID 1 is reserved for the default VLAN). VLAN range is 2-4094.

Format `no vlan <2-4094>`

Mode VLAN database

7.6.3 *vlan acceptframe*

This command sets the frame acceptance mode per interface. For VLAN Only mode, untagged frames or priority frames received on this interface are discarded. For Admit All mode, untagged frames or priority frames received on this interface are accepted and assigned the value of the

interface VLAN ID for this port. With either option, VLAN tagged frames are forwarded in accordance with the IEEE 802.1Q VLAN Specification.

Default admit all

Format vlan acceptframe <vlanonly | all>

Mode Interface Config

7.6.3.1 no vlan acceptframe

This command sets the frame acceptance mode per interface to **Admit All**. For Admit All mode, untagged frames or priority frames received on this interface are accepted and assigned the value of the interface VLAN ID for this port. With either option, VLAN tagged frames are forwarded in accordance with the IEEE 802.1Q VLAN Specification.

Format vlan acceptframe <vlanonly | all>

Mode Interface Config

7.6.4 vlan ingressfilter

This command enables ingress filtering. If ingress filtering is disabled, frames received with VLAN IDs that do not match the VLAN membership of the receiving interface are admitted and forwarded to ports that are members of that VLAN.

Default disabled

Format vlan ingressfilter

Mode Interface Config

7.6.4.1 no vlan ingressfilter

This command disables ingress filtering. If ingress filtering is disabled, frames received with VLAN IDs that do not match the VLAN membership of the receiving interface are admitted and forwarded to ports that are members of that VLAN.

Format no vlan ingressfilter

Mode Interface Config

7.6.5 vlan makestatic

This command changes a dynamically created VLAN (one that is created by GVRP registration) to a static VLAN (one that is permanently configured and defined). The ID is a valid VLAN identification number. VLAN range is 2-4094.

Format vlan makestatic <2-4094>

Mode VLAN database

7.6.6 *vlan name*

This command changes the name of a VLAN. The name is an alphanumeric string of up to 32 characters, and the ID is a valid VLAN identification number. ID range is 1-4094.

Default The name for VLAN ID 1 is always Default. The name for other VLANs is defaulted to a blank string.

Format `vlan name <2-4094> <name>`

Mode VLAN data base

7.6.6.1 *no vlan name*

This command sets the name of a VLAN to a blank string. The VLAN ID is a valid VLAN identification number. ID range is 1-4094.

Format `no vlan name <2-4094>`

Mode VLAN database

7.6.7 *vlan participation*

This command configures the degree of participation for a specific interface in a VLAN. The ID is a valid VLAN identification number, and the interface is a valid interface number .

Format `vlan participation <exclude | include | auto> <1-4094>`

Mode Interface Config

Participation options are:

include The interface is always a member of this VLAN. This is equivalent to registration fixed.

exclude The interface is never a member of this VLAN. This is equivalent to registration forbidden.

auto The interface is dynamically registered in this VLAN by GVRP. The interface will not participate in this VLAN unless a join request is received on this interface. This is equivalent to registration normal.

7.6.8 *vlan participation all*

This command configures the degree of participation for all interfaces in a VLAN. The ID is a valid VLAN identification number.

Format `vlan participation all <exclude | include | auto> <1-4094>`

Mode Global Config

Participation options are:

include The interface is always a member of this VLAN. This is equivalent to registration fixed.

exclude The interface is never a member of this VLAN. This is equivalent to registration forbidden.

auto The interface is dynamically registered in this VLAN by GVRP. The interface will not participate in this VLAN unless a join request is received on this interface. This is equivalent to registration normal.

7.6.9 *vlan port acceptframe all*

This command sets the frame acceptance mode for all interfaces. For VLAN Only mode, untagged frames or priority frames received on this interface are discarded. For Admit All mode, untagged frames or priority frames received on this interface are accepted and assigned the value of the interface VLAN ID for this port. With either option, VLAN tagged frames are forwarded in accordance with the IEEE 802.1Q VLAN Specification.

Default admit all

Format vlan port acceptframe all <*vlanonly* | *all*>

Mode Global Config

7.6.9.1 *no vlan port acceptframe all*

This command sets the frame acceptance mode for all interfaces to **Admit All**. For Admit All mode, untagged frames or priority frames received on this interface are accepted and assigned the value of the interface VLAN ID for this port. With either option, VLAN tagged frames are forwarded in accordance with the IEEE 802.1Q VLAN Specification.

Format no vlan port acceptframe all

Mode Global Config

7.6.10 *vlan port ingressfilter all*

This command enables ingress filtering for all ports. If ingress filtering is disabled, frames received with VLAN IDs that do not match the VLAN membership of the receiving interface are admitted and forwarded to ports that are members of that VLAN.

Default disabled

Format vlan port ingressfilter all

Mode Global Config

7.6.10.1 *no vlan port ingressfilter all*

This command disables ingress filtering for all ports. If ingress filtering is disabled, frames received with VLAN IDs that do not match the VLAN membership of the receiving interface are admitted and forwarded to ports that are members of that VLAN.

Format no vlan port ingressfilter all

Mode Global Config

7.6.11 *vlan port pvid all*

This command changes the VLAN ID for all interface.

Default 1

Format vlan port pvid all <1-4094>

Mode Global Config

7.6.11.1 *no vlan port pvid all*

This command sets the VLAN ID for all interfaces to 1.

Format no vlan port pvid all

Mode Global Config

7.6.12 *vlan port tagging all*

This command configures the tagging behavior for all interfaces in a VLAN to enabled. If tagging is enabled, traffic is transmitted as tagged frames. If tagging is disabled, traffic is transmitted as untagged frames. The ID is a valid VLAN identification number.

Format vlan port tagging all <1-4094>

Mode Global Config

7.6.12.1 *no vlan port tagging all*

This command configures the tagging behavior for all interfaces in a VLAN to disabled. If tagging is disabled, traffic is transmitted as untagged frames. The ID is a valid VLAN identification number.

Format no vlan port tagging all

Mode Global Config

7.6.13 *vlan protocol group*

This command adds protocol-based VLAN group to the system. The <groupName> is a character string of 1 to 16 characters. When it is created, the protocol group will be assigned a unique number that will be used to identify the group in subsequent commands.

Format vlan protocol group <groupname>

Mode Global Config

7.6.14 *vlan protocol group add protocol*

This command adds the <protocol> to the protocol-based VLAN identified by <groupid>. A group may have more than one protocol associated with it. Each interface and protocol combination can only be associated with one group. If adding a protocol to a group causes any conflicts with interfaces currently associated with the group, this command will fail and the protocol will not be added to the group. The possible values for protocol are *ip*, *arp*, and *ipx*.

Default none

Format vlan protocol group add protocol <groupid> <protocol>

Mode Global Config

7.6.14.1 no vlan protocol group add protocol

This command removes the <protocol> from this protocol-based VLAN group that is identified by this <groupid>. The possible values for protocol are *ip*, *arp*, and *ipx*.

Format no vlan protocol group add protocol <groupid> <protocol>

Mode Global Config

7.6.15 vlan protocol group remove

This command removes the protocol-based VLAN group that is identified by this <groupid>.

Format vlan protocol group remove <groupid>

Mode Global Config

7.6.16 protocol group

This command attaches a <vlanid> to the protocol-based VLAN identified by <groupid>. A group may only be associated with one VLAN at a time, however the VLAN association can be changed.

The referenced VLAN should be created prior to the creation of the protocol-based VLAN except when GVRP is expected to create the VLAN.

Default none

Format protocol group <groupid> <vlanid>

Mode VLAN database

7.6.16.1 no protocol group

This command removes the <vlanid> from this protocol-based VLAN group that is identified by this <groupid>.

Format no protocol group <groupid> <vlanid>

Mode VLAN database

7.6.17 protocol vlan group

This command adds the physical <unit/slot/port> interface to the protocol-based VLAN identified by <groupid>. A group may have more than one interface associated with it. Each interface and protocol combination can only be associated with one group. If adding an interface to a group causes any conflicts with protocols currently associated with the group, this command will fail and the interface(s) will not be added to the group.

The referenced VLAN should be created prior to the creation of the protocol-based VLAN except when GVRP is expected to create the VLAN.

Default none

Format protocol vlan group <groupid>

Mode Interface Config

7.6.17.1 no protocol vlan group

This command removes the <interface> from this protocol-based VLAN group that is identified by this <groupid>. If <all> is selected, all ports will be removed from this protocol group.

Format no protocol vlan group <groupid>

Mode Interface Config

7.6.18 protocol vlan group all

This command adds all physical interfaces to the protocol-based VLAN identified by <groupid>. A group may have more than one interface associated with it. Each interface and protocol combination can only be associated with one group. If adding an interface to a group causes any conflicts with protocols currently associated with the group, this command will fail and the interface(s) will not be added to the group.

The referenced VLAN should be created prior to the creation of the protocol-based VLAN except when GVRP is expected to create the VLAN.

Default none

Format protocol vlan group all <groupid>

Mode Global Config

7.6.18.1 no protocol vlan group all

This command removes all interfaces from this protocol-based VLAN group that is identified by this <groupid>.

Format no protocol vlan group all <groupid>

Mode Global Config

7.6.19 vlan pvid

This command changes the VLAN ID per interface.

Default 1

Format vlan pvid <1-4094>

Mode Interface Config

7.6.19.1 no vlan pvid

This command sets the VLAN ID per interface to 1.

Format no vlan pvid

Mode Interface Config

7.6.20 vlan tagging

This command configures the tagging behavior for a specific interface in a VLAN to enabled. If tagging is enabled, traffic is transmitted as tagged frames. If tagging is disabled, traffic is transmitted as untagged frames. The ID is a valid VLAN identification number.

Format vlan tagging <1-4094>

Mode Interface Config

7.6.20.1 no vlan tagging

This command configures the tagging behavior for a specific interface in a VLAN to disabled. If tagging is disabled, traffic is transmitted as untagged frames. The ID is a valid VLAN identification number.

Format no vlan tagging <1-4094>

Mode Interface Config

7.6.21 show vlan

This command displays detailed information, including interface information, for a specific VLAN. The ID is a valid VLAN identification number

Format show vlan <vlanid>

Modes Privileged EXEC

User EXEC

VLAN ID There is a VLAN Identifier (VID) associated with each VLAN. The range of the VLAN ID is 1 to 4094.

VLAN Name A string associated with this VLAN as a convenience. It can be up to 32 alphanumeric characters long, including blanks. The default is blank. VLAN ID 1 always has a name of `Default`. This field is optional.

VLAN Type Type of VLAN, which can be Default, (VLAN ID = 1), a static (one that is configured and permanently defined), or Dynamic (one that is created by GVRP registration).

Unit/Slot/Port Valid unit, slot and port number separated by forward slashes. It is possible to set the parameters for all ports by using the selectors on the top line.

Current Determines the degree of participation of this port in this VLAN. The permissible values are:

Include - This port is always a member of this VLAN. This is equivalent to registration fixed in the IEEE 802.1Q standard.

Exclude - This port is never a member of this VLAN. This is equivalent to registration forbidden in the IEEE 802.1Q standard.

Autodetect - Specifies to allow the port to be dynamically registered in this VLAN via GVRP. The port will not participate in this VLAN unless a join request is received on this port. This is equivalent to registration normal in the IEEE 802.1Q standard.

Configured Determines the configured degree of participation of this port in this VLAN. The permissible values are:

Include - This port is always a member of this VLAN. This is equivalent to registration fixed in the IEEE 802.1Q standard.

Exclude - This port is never a member of this VLAN. This is equivalent to registration

forbidden in the IEEE 802.1Q standard. **Autodetect** - Specifies to allow the port to be dynamically registered in this VLAN via GVRP. The port will not participate in this VLAN unless a join request is received on this port. This is equivalent to registration normal in the IEEE 802.1Q standard.

Tagging Select the tagging behavior for this port in this VLAN.

Tagged - specifies to transmit traffic for this VLAN as tagged frames.

Untagged - specifies to transmit traffic for this VLAN as untagged frames.

7.6.22 *show vlan brief*

This command displays a list of all configured VLANs.

Format `show vlan brief`

Modes Privileged EXEC User EXEC

VLAN ID There is a VLAN Identifier (vlanid) associated with each VLAN. The range of the VLAN ID is 1 to 4094.

VLAN Name A string associated with this VLAN as a convenience. It can be up to 32 alphanumeric characters long, including blanks. The default is blank. VLAN ID 1 always has a name of 'Default'. This field is optional.

VLAN Type Type of VLAN, which can be Default, (VLAN ID = 1), a static (one that is configured and permanently defined), or a Dynamic (one that is created by GVRP registration).

7.6.23 *show vlan port*

This command displays VLAN port information.

Format show vlan port {<unit/slot/port> | all}

Modes Privileged EXEC

User EXEC

Unit/Slot/Port Valid unit, slot and port number separated by forward slashes. It is possible to set the parameters for all ports by using the selectors on the top line.

Port VLAN ID The VLAN ID that this port will assign to untagged frames or priority tagged frames received on this port. The value must be for an existing VLAN. The factory default is 1.

Acceptable Frame Types Specifies the types of frames that may be received on this port. The options are 'VLAN only' and 'Admit All'. When set to 'VLAN only', untagged frames or priority tagged frames received on this port are discarded. When set to 'Admit All', untagged frames or priority tagged frames received on this port are accepted and assigned the value of the Port VLAN ID for this port. With either option, VLAN tagged frames are forwarded in accordance to the 802.1Q VLAN specification.

Ingress Filtering May be enabled or disabled. When enabled, the frame is discarded if this port is not a member of the VLAN with which this frame is associated. In a tagged frame, the VLAN is identified by the VLAN ID in the tag. In an untagged frame, the VLAN is the Port VLAN ID specified for the port that received this frame. When disabled, all frames are forwarded in accordance with the 802.1Q VLAN bridge specification. The factory default is disabled.

GVRP May be enabled or disabled.

Default Priority The 802.1p priority assigned to tagged packets arriving on the port.

7.6.24 *vtrunk set*

This command configures port as trunk port, the port is included into the all VLAN's that are mentioned in <vlan-list>, and traffic will be transmitted as tagged. The syntax of the <vlan-list> is separate non-consecutive VLAN IDs with a comma and no spaces; use a hyphen to designate a range of IDs.

Format vtrunk set {<vlan-list>}

Modes Interface config

<vlan-list> The syntax of the <vlan-list> is separate non-consecutive VLAN IDs with a comma and no spaces; use a hyphen to designate a range of IDs. For example, you may set "vtrunk set 1,2,5-8".

7.6.25 *vtrunk clear*

This command remove the vlan id specified in <vlan-list> from this interface.

Format vtrunk clear {<vlan-list>}

Modes Interface config

<vlan-list> The syntax of the <vlan-list> is separate non-consecutive VLAN IDs with a comma

and no spaces; use a hyphen to designate a range of IDs. For example, you may set “vtrunk set 1,2,5-8”.

7.7 System Utility Commands

This section describes system utilities. The commands are divided into two functional groups:

- Show commands display switch settings, statistics, and other information.
- Configuration commands configure features and options of the switch. For every configuration command, there is a show command that displays the configuration setting.

7.7.1 *traceroute*

This command is used to discover the routes that packets actually take when traveling to their destination through the network on a hop-by-hop basis. <ipaddr> should be a valid IP address. [port] should be a valid decimal integer in the range of 0(zero) to 65535. The default value is 33434.

The optional port parameter is the UDP port used as the destination of packets sent as part of the traceroute. This port should be an unused port on the destination system.

Format traceroute <ipaddr> [port]

Mode Privileged EXEC

7.7.2 *clear config*

This command resets the configuration to the factory defaults without powering off the switch. The switch is automatically reset when this command is processed. You are prompted to confirm that the reset should proceed.

Format clear config

Mode Privileged EXEC

7.7.3 *clear counters*

This command clears the stats for a specified <unit/slot/port> or for all the ports or for the entire switch based upon the argument.

Format clear counters {<unit/slot/port> | all}

Mode Privileged EXEC

7.7.4 *clear igmpsnooping*

This command clears the tables managed by the IGMP Snooping function and will attempt to delete these entries from the Multicast Forwarding Database.

Format clear igmpsnooping

Mode Privileged EXEC

7.7.5 clear pass

This command resets all user passwords to the factory defaults without powering off the switch. You are prompted to confirm that the password reset should proceed.

Format clear pass

Mode Privileged EXEC

7.7.6 enable passwd

This command changes the Privileged EXEC password. First type the command then hit the enter or the return key.

Format enable passwd

Mode Privileged EXEC

7.7.7 clear port-channel

This command clears all port-channels (LAGs).

Format clear port-channel

Mode Privileged EXEC

7.7.8 clear traplog

This command clears the trap log.

Format clear traplog

Mode Privileged EXEC

7.7.9 clear vlan

This command resets VLAN configuration parameters to the factory defaults.

Format clear vlan

Mode Privileged EXEC

7.7.10 logout

This command closes the current telnet connection or resets the current serial connection.

Note: Save configuration changes before logging out.

Format logout

Mode Privileged EXEC

7.7.11 ping

This command checks if another computer is on the network and listens for connections. To use this command, configure the switch for network (in-band) connection. The source and target devices must have the ping utility enabled and running on top of TCP/IP. The switch can be pinged from any IP workstation with which the switch is connected through the default VLAN (VLAN 1), as long as there is a physical path between the switch and the workstation. The terminal interface sends, three pings to the target station.

Format ping <ipaddr>

Modes Privileged EXEC

User EXEC

7.7.12 reload

This command resets the switch without powering it off. Reset means that all network connections are terminated and the boot code executes. The switch uses the stored configuration to initialize the switch. You are prompted to confirm that the reset should proceed. A successful reset is indicated by the LEDs on the switch.

Format reload

Mode Privileged EXEC

7.7.13 copy

This command uploads and downloads to/from the switch. Local URLs can be specified using tftp or xmodem. The following can be specified as the source file for uploading from the switch: startup configuration (***nvram:startup-config***), error log (***nvram:errorlog***), message log (***nvram:msglog***), trap log (***nvram:traplog***) and configuration script(***nvram:script <scriptname>***). A URL(***tftp://<ip address>/***) is specified for the destination and the destination file ***<filename>***.

The command can also be used to download the startup configuration, code image or configuration script by specifying the source as a URL and destination as ***nvram:startup-config***, ***.system:image*** or ***nvram:script*** respectively.

The <scriptname> is the name of the script file to be uploaded. During download of a configuration script the copy command will validate the script being downloaded. In case of any error, the command will list all the line at the end of validation process and confirm from user for copying the script file.

The command can be used to save the running configuration to nvram by specifying the source as ***system:running-config*** and the destination as ***nvram:startup-config***

The command can also be used to download ssh key files as **nvr_{am}:sshkey-rsa**, **nvr_{am}:sshkey-rsa2**, and **nvr_{am}:sshkey-dsa** and http secure-server certificates as **nvr_{am}:sslpem-root**, **nvr_{am}:sslpem-server**, **nvr_{am}:sslpem-dhweak**, and **nvr_{am}:sslpem-dhstrong**.

Default none

Format copy nvr_{am}:startup-config <tftp://<ip address>/> <filename>
copy nvr_{am}:clibanner <tftp://<ip address>/> <filename>
copy nvr_{am}:log <tftp://<ip address>/> <filename>
copy nvr_{am}:errorlog <tftp://<ip address>/> <filename>
copy nvr_{am}:msglog <tftp://<ip address>/> <filename>
copy nvr_{am}:traplog <tftp://<ip address>/> <filename>
copy nvr_{am}:script <scriptname> <tftp://<ip address>/> <file-name> <filename>
copy <tftp://<ip address>/> <filename> nvr_{am}:startup-config
copy <tftp://<ip address>/> <filename> system:image
copy <tftp://<ip address>/> <filename> nvr_{am}:script
copy system:running-config nvr_{am}:startup-config
copy <tftp://<ip address>/> <filename> nvr_{am}:sslpem-root
copy <tftp://<ip address>/> <filename> nvr_{am}:sslpem-server
copy <tftp://<ip address>/> <filename> nvr_{am}:sslpem-dhweak
copy <tftp://<ip address>/> <filename> nvr_{am}:sslpem-dhstrong
copy <tftp://<ip address>/> <filename> nvr_{am}:sshkey-rsa1
copy <tftp://<ip address>/> <filename> nvr_{am}:sshkey-rsa2
copy <tftp://<ip address>/> <filename> nvr_{am}:sshkey-dsa
copy <tftp://<ip address>/> <filename> nvr_{am}:clibanner

Mode Privileged EXEC

7.7.14 autosave

This command enables/disables auto-saving user configuration to flash memory. Assigning “0” represents disables the auto-save mode while entering a number represents the period in minutes to save the changes to flash memory.

Format autosave <0-600>
Mode Privileged EXEC

7.7.15 cpu-port-security

This command enables the CPU MAC Filtering.

Format cpu-port-security
Mode Privileged EXEC

7.7.15.1 no cpu-port-security

This command disables the CPU MAC Filtering.

Format **no cpu-port-security**

Mode **Privileged EXEC**

7.7.16 cpu-port-security max-entries

This command sets the max number of entries in the allow/deny list for CPU MAC filter. Default 50.

Format **cpu-port-security max-entries <0-50>**

Mode **Privileged EXEC**

7.7.17 cpu-port-security allow

This command enables allowing the mac addresses to CPU.

Format **cpu-port-security allow**

Mode **Privileged EXEC**

7.7.17.1 no cpu-port-security allow

This command disables allowing the mac addresses to CPU.

Format **no cpu-port-security allow**

Mode **Privileged EXEC**

7.7.18 cpu-port-security allow

This command adds Static MAC address to be allowed to CPU

Format **cpu-port-security allow <mac-addr>**

Mode **Privileged EXEC**

7.7.18.1 no cpu-port-security allow

This command removes Static MAC address to be allowed to CPU

Format **cpu-port-security allow <mac-addr>**

Mode **Privileged EXEC**

7.7.19 cpu-port-security deny

This command enables denying the mac addresses to CPU.

Format **cpu-port-security deny**

Mode **Privileged EXEC**

7.7.19.1 no cpu-port-security deny

This command disables denying the mac addresses to CPU.

Format **no cpu-port-security deny**

Mode **Privileged EXEC**

7.7.20 cpu-port-security deny

This command adds Static MAC address to be denied to CPU.

Format **cpu-port-security deny <mac-addr>**

Mode **Privileged EXEC**

7.7.20.1 no cpu-port-security deny <mac-addr>

This command removes Static MAC address to be denied to CPU

Format **cpu-port-security deny <mac-addr>**

Mode **Privileged EXEC**

7.7.21 show cpu statistics

This command displays CPU statistics for the management switch unit.

Format **show cpu statistics**

Mode **Privileged EXEC**

Total Memory(kb) displays the total memory of the switch.

Used Memory(kb) displays the used memory of the switch.

Free Memory(kb) displays the free memory of the switch.

CPU Utilization displays the percentage of the CPU being utilized.

7.7.22 show cpu-port-security

This command display the Global CPU MAC Filter properties.

Format **show cpu-port-security**

Mode **Privileged EXEC**

Global Admin mode indicates the mode of CPU MAC filter is enabled or disabled.

Filering Mode indicates the filtering mode of CPU MAC filter is allowing or denying.

Max Entries indicates the maximum number of MAC to be filtered.

S. No indicates sequence number.

MAC Address indicates the list of MAC addresses to be filtered.

7.8 Pre-login Banner Command

This section provides a detailed explanation of the Pre-login Banner command.

7.8.1 *copy*

The **copy** command (See “copy” on page 65.) includes the “clibanner” option. This command uploads and downloads to/from the switch. Local URLs can be specified using tftp or xmodem.

Default none

Format copy <tftp://<ip address>/> <filename> nvram:clibanner

Mode Privileged EXEC

7.9 CLI Command Logging Command

This section provides a detailed explanation of the CLI Command Logging commands.

7.9.1 *logging cli-command*

This command enables the CLI command Logging feature. The Command Logging component enables the switch to log all Command Line Interface (CLI) commands issued on the system.

Default enabled

Format logging cli-command

Mode Global Config

7.9.1.1 *no logging cli-command*

Format no logging cli-command

Mode Global Config

7.10 Configuration Scripting Commands

Configuration Scripting allows the user to generate text-formatted script files representing the current configuration. These configuration script files can be uploaded to a PC and edited, downloaded to the system and applied to the system. Configuration scripts can be applied to one or more switches with no/ minor modifications.

Use the show running-config command (“show running-config” on page 29) to capture the running configuration into a script. Use the copy command (See “copy” on page 65.) to transfer the configuration script to/from the switch.

Scripts are intended to be used on systems with default configuration but users are not prevented from applying scripts on systems with non-default configurations.

Note:

- The file extension must be “.scr”.
- A maximum of ten scripts are allowed on the switch.
- The combined size of all script files on the switch shall not exceed 2048 KB.

7.10.1 *script apply*

This command applies the commands in the configuration script to the switch. We recommend that the system have default configuration but users are not prevented from applying scripts on systems with non-default configurations. The <scriptname> parameter is the name of the script to be applied.

Format script apply <scriptname>

Mode Global Config

7.10.2 *script delete*

This command deletes a specified script where the <scriptname> parameter is the name of the script to be deleted. The ‘all’ option deletes all the scripts present on the switch.

Format script delete {<scriptname> | all}

Mode Global Config

7.10.3 *script list*

This command lists all scripts present on the switch as well as the available space remaining.

Format script list

Mode Global Config

Configuration Script Name of the configuration script.

Size Size of the configuration script.

7.10.4 script show

This command displays the contents of a script file. The parameter <scriptname> is the name of the script file.

Format script show <scriptname>

Mode Global Config

The format of display is Line <no>: <Line contents>

7.10.5 script validate

This command validates a configuration script file by parsing each line in the script file where <scriptname> is the name of the script to be validated. The validate option is intended to be used as a tool for script development. Validation will identify potential problems. It may or may not identify all problems with a given script on any given box.

Format script validate <scriptname>

Mode Global Config

7.11 System Log (Syslog) Commands

This section provides a detailed explanation of the Syslog commands. The commands are divided into two functional groups:

- Show commands display spanning tree settings, statistics, and other information.
- Configuration Commands configure features and options of the device. For every configuration command there is a show command that displays the configuration setting.

7.11.1 *logging buffered*

This command enables logging to an in-memory log where up to 128 logs are kept. The <severitylevel> value is specified as either an integer from 0 to 7 or symbolically through one of the following keywords: emergency (0), alert (1), critical (2), error (3), warning (4), notice (5), informational (6), debug (7).

Default disabled; critical

Format logging buffered [severitylevel]

Mode Global Config

7.11.1.1 *no logging buffered*

This command disables logging to in-memory log.

Format no logging buffered

Mode Global Config

7.11.2 *logging buffered wrap*

This command enables wrapping of in-memory logging when full capacity reached. Otherwise when full capacity is reached, logging stops.

Default wrap

Format logging buffered wrap

Mode Privileged EXEC

7.11.2.1 *no logging wrap*

This command disables wrapping of in-memory logging and configures logging to stop when capacity is full.

Format no logging buffered wrap

Mode Privileged EXEC

7.11.3 logging console

This command enables logging to the console. The <severitylevel> value is specified as either an integer from 0 to 7 or symbolically through one of the following keywords: emergency (0), alert (1), critical (2), error (3), warning (4), notice (5), informational (6), debug (7).

Default disabled; critical

Format logging console [severitylevel]

Mode Global Config

7.11.3.1 no logging console

This command disables logging to the console.

Format no logging console

Mode Global Config

7.11.4 logging persistent

This command enables logging of system startup and system operation logs to storage. The <severitylevel> value is specified as either an integer from 0 to 7 or symbolically through one of the following keywords: EMERGENCY (0), ALERT (1), CRITICAL (2), ERROR (3), WARNING (4), NOTICE (5), INFORMATIONAL (6), DEBUG (7).

Default enabled; severitylevel - critical

Format logging persistent [<severitylevel>]

Mode Global Config

7.11.4.1 no logging persistent

This command disables logging. It does not clear the contents of the log.

Format no logging persistent

Mode Global Config

7.11.5 logging host

This command enables logging to a host where up to eight hosts can be configured. AddressType can be ipv4 or dns, port can be of a value from

Default Port - 514; Level - Critical;

Format logging host <ipaddress> <addresstype> [port <port>] [level
<severitylevel>]

Mode Global Config

7.11.6 logging syslog

This command enables syslog logging.

Default disabled; local0

Format logging syslog

Mode Global Config

7.11.6.1 no logging syslog

This command disables syslog logging.

Format no logging syslog

Mode Global Config

7.11.7 logging syslog port

This command enables syslog logging for assigned port.

Default disabled; local0

Format logging syslog

Mode Global Config

7.11.7.1 no logging syslog port

This command disables syslog logging for assigned port.

Format no logging syslog port

Mode Global Config

7.11.8 show logging

This command displays logging.

Format show logging

Mode Privileged EXEC

Client Local Port The port on the collector/relay to which syslog messages are sent.

Console Logging Administrative Mode The mode for console logging.

Console Logging Severity Filter The minimum severity to log to the console log. Messages with an equal or lower numerical severity are logged.

Buffered Logging Administrative Mode The mode for buffered logging.

Buffered Logging Severity Filter The minimum severity to log to the buffered log. Messages with an equal or lower numerical severity are logged.

Historical Logging Administrative Mode The mode for historical logging.

Historical Logging Severity Filter The minimum severity to log to the historical log. Messages with an equal or lower numerical severity are logged.

Syslog Logging Administrative Mode The mode for logging to configured syslog hosts. If set to disable logging stops to all syslog hosts.

Log Messages Received The number of messages received by the log process. This includes messages that are dropped or ignored

Log Messages Dropped The number of messages that could not be processed.

7.11.9 *show logging persistent*

This command displays logging.

Format show logging persistent

Mode Privileged EXEC

Persistent Logging Administrative Mode The mode for historical logging.

Persistent Logging Severity Filter The minimum severity to log to the historical log. Messages with an equal or lower numerical severity are logged.

Persistent Log Count: The number of messages received by the log process. This includes messages that are dropped or ignored

Log Messages: The log messages appear here.

7.11.10 *show logging buffered*

This command displays buffered logging (system startup and system operation logs).

Format show logging buffered

Mode Privileged EXEC

Admin Status The current state of the in-memory log.

Severity Level Filter The minimum severity to log to the in memory log. Messages with an equal or lower numerical severity are logged.

Component Filter The component(s) from which received messages are to be logged to the in memory log. Either a single component id or "all components" may be specified.

Wrapping Behavior The behavior of the In Memory log when faced with a log full situation.

Log Count The count of valid entries in the buffered log.

Log Messages: The log messages appear here.

7.11.11 show logging hosts

This command displays all configured logging hosts.

Format show logging hosts

Mode Privileged EXEC

Host Index (Used for deleting hosts)

Host IP Address IP Address of the configured server.

Address Type Address Type of Server.

Severity Level The minimum severity to log to the specified address.

Port Server Port Number. This is the port on the local host from which syslog messages are sent.

Host Status The state of logging to configured syslog hosts. If the status is disable, no logging occurs.

Log Messages: The log messages appear here.

7.11.12 show logging traplogs

This command displays traprecords.

Format show logging traplogs

Mode Privileged EXEC

Number of Trap Since last Reset shows the no. of traps after restarting the switch.

Trap Log Capacity shows the max. no of the trap log that the swith could record.

Number of Trap Since last viewed shows the no. of traps after you had monitored the trap by this command.

7.12 User Account Commands

These commands manage user accounts. The commands are divided into two functional groups:

- Show commands display switch settings, statistics, and other information.
- Configuration commands configure features and options of the switch. For every configuration command, there is a show command that displays the configuration setting.

7.12.1 *disconnect*

This command closes a telnet session.

Format `disconnect {<sessionID> | all}`

Mode Privileged EXEC

7.12.2 *show loginsession*

This command displays current telnet and serial port connections to the switch.

Format `show loginsession`

Mode Privileged EXEC

ID Login Session ID

User Name The name the user will use to login using the serial port or Telnet. A new user may be added to the switch by entering a name in a blank entry. The user name may be up to 8 characters, and is not case sensitive. Two users are included as the factory default, 'admin' and 'guest'.

Connection From IP address of the telnet client machine or EIA-232 for the serial port connection.

Idle Time Time this session has been idle.

Session Time Total time this session has been connected.

7.12.3 *show users*

This command displays the configured user names and their settings. This command is only available for users with Read/Write privileges. The SNMPv3 fields will only be displayed if SNMP is available on the system.

Format `show users`

Mode Privileged EXEC

User Name The name the user will use to login using the serial port, Telnet or Web. A new user may be added to the switch by entering a name in a blank entry. The user name may be up to eight characters, and is not case sensitive. Two users are included as the factory default, 'admin' and 'guest'

Access Mode Shows whether the operator is able to change parameters on the switch (Read/Write) or is only able to view them (Read Only). As a factory default, the 'admin' user has Read/Write access and the 'guest' has Read Only access. There can only be one Read/ Write user and up to five Read Only users.

SNMPv3 Access Mode This field displays the SNMPv3 Access Mode. If the value is set to **Read-Write**, the SNMPv3 user will be able to set and retrieve parameters on the system. If the value is set to **ReadOnly**, the SNMPv3 user will only be able to retrieve parameter information. The SNMPv3 access mode may be different than the CLI and Web access mode.

SNMPv3 Authentication This field displays the authentication protocol to be used for the specified login user.

SNMPv3 Encryption This field displays the encryption protocol to be used for the specified login user.

7.12.4 users name

This command adds a new user (account) if space permits. The account <username> can be up to eight characters in length. The name may be comprised of alphanumeric characters as well as the dash ('-') and underscore ('_'). The <username> is not case-sensitive.

Six user names can be defined.

Format users name <username>

Mode Global Config

7.12.4.1 no users name

This command removes an operator.

Format no users name <username>

Mode Global Config

Note: The 'admin' user account cannot be deleted.

7.12.5 users passwd

This command is used to change a password. The password should not be more than eight alphanumeric characters in length. If a user is authorized for authentication or encryption is enabled, the password must be at least eight alphanumeric characters in length. The username and password are not case-sensitive. When a password is changed, a prompt will ask for the former password. If none, press enter.

Default no password

Format users passwd <username>

Mode Global Config

7.12.5.1 no users passwd

This command sets the password of an existing operator to blank. When a password is changed, a prompt will ask for the operator's former password. If none, press enter.

Format no users passwd <username>

Mode Global Config

7.12.6 users snmpv3 accessmode

This command specifies the snmpv3 access privileges for the specified login user. The valid accessmode values are **readonly** or **readwrite**. The <username> is the login user name for which the specified access mode applies. The default is **readwrite** for 'admin' user; **readonly** for all other users

Default admin -- readwrite; other -- readonly

Format users snmpv3 accessmode <username> <readonly | readwrite>

Mode Global Config

7.12.6.1 no users snmpv3 accessmode

This command sets the snmpv3 access privileges for the specified login user as **readwrite** for the 'admin' user; **readonly** for all other users. The <username> is the login user name for which the specified access mode will apply.

Format no users snmpv3 accessmode <username>

Mode Global Config

7.12.7 users snmpv3 authentication

This command specifies the authentication protocol to be used for the specified login user. The valid authentication protocols are **none**, **md5** or **sha**. If md5 or sha are specified, the user login password is also used as the snmpv3 authentication password and therefore must be at least eight characters in length. The <username> is the login user name associated with the authentication protocol.

Default no authentication

Format users snmpv3 authentication <username> <none | md5 | sha>

Mode Global Config

7.12.7.1 no users snmpv3 authentication

This command sets the authentication protocol to be used for the specified login user to **none**. The <username> is the login user name for which the specified authentication protocol will be used.

Format users snmpv3 authentication <username>

Mode Global Config

7.12.8 users snmpv3 encryption

This command specifies the encryption protocol to be used for the specified login user. The valid encryption protocols are des or **none**.

If des is specified, the required key may be specified on the command line. The encryption **key** must be 8 to 64 characters long. If the **des** protocol is specified but a key is not provided, the user will be prompted for the key. When using the des protocol, the user login password is also used as the snmpv3 encryption password and therefore must be at least eight characters in length.

If **none** is specified, a key must not be provided. The <username> is the login user name associated with the specified encryption.

Default no encryption

Format users snmpv3 encryption <username> <none | des[key]>

Mode Global Config

5.12.8.1 no users snmpv3 encryption

This command sets the encryption protocol to **none**. The <username> is the login user name for which the specified encryption protocol will be used.

Format no users snmpv3 encryption <username>

Mode Global Config

7.13 Simple Network Time Protocol (SNTP) Commands

This section provides a detailed explanation of the SNTP commands. The commands are divided into two functional groups:

- Show commands display spanning tree settings, statistics, and other information.
- Configuration Commands configure features and options of the switch. For every configuration command there is a show command that displays the configuration setting.

7.13.1 *sntp broadcast client poll-interval*

This command will set the poll interval for SNTP broadcast clients in seconds as a power of two where <poll-interval> can be a value from 6 to 16.

Default 6

Format sntp broadcast client poll-interval <poll-interval>

Mode Global Config

7.13.1.1 *no sntp broadcast client poll-interval*

This command will reset the poll interval for SNTP broadcast client back to its default value.

Format no sntp broadcast client poll-interval

Mode Global Config

7.13.2 *sntp client mode*

This command will enable Simple Network Time Protocol (SNTP) client mode and optionally setting the mode to either broadcast, multicast, or unicast.

Default Disabled

Format sntp client mode [broadcast | multicast | unicast]

Mode Global Config

7.13.2.1 *sntp client mode*

This command will disable Simple Network Time Protocol (SNTP) client mode.

Format no sntp client mode

Mode Global Config

7.13.3 *sntp client port*

This command will set the SNTP client port id to a value from 1-65535.

Default 123

Format sntp client port <portid>

Mode Global Config

7.13.3.1 *no sntp client port*

This command will reset the SNTP client port back to its default value.

Format no sntp client port

Mode Global Config

7.13.4 *sntp unicast client poll-interval*

This command will set the poll interval for SNTP unicast clients in seconds as a power of two where <poll-interval> can be a value from 6 to 16.

Default 6

Format sntp unicast client poll-interval <poll-interval>

Mode Global Config

7.13.4.1 *no sntp unicast client poll-interval*

This command will reset the poll interval for SNTP unicast clients to its default value.

Format no sntp unicast client poll-interval

Mode Global Config

7.13.5 *sntp unicast client poll-timeout*

This command will set the poll timeout for SNTP unicast clients in seconds to a value from 1-30.

Default 5

Format sntp unicast client poll-timeout <poll-timeout>

Mode Global Config

7.13.5.1 *no sntp unicast client poll-timeout*

This command will reset the poll timeout for SNTP unicast clients to its default value.

Format no sntp unicast client poll-timeout

Mode Global Config

7.13.6 sntp unicast client poll-retry

This command will set the poll retry for SNTP unicast clients to a value from 0 to 10.

Default 1

Format sntp unicast client poll-retry <poll-retry>

Mode Global Config

7.13.6.1 no sntp unicast client poll-retry

This command will reset the poll retry for SNTP unicast clients to its default value.

Format no sntp unicast client poll-retry

Mode Global Config

7.13.7 sntp server

This command configures an SNTP server (with a maximum of three) where the server address can be an ip address or a domain name and the address type either ipv4 or dns. The optional priority can be a value of 1-3, the version a value of 1-4, and the port id a value of 1-65535.

Format sntp server <ipaddress/domain-name> <addresstype> [<priority>[<version> [<portid>]]]

Mode Global Config

7.13.7.1 no sntp server

This command deletes an server from the configured SNTP servers.

Format no sntp server remove <ipaddress/domain-name>

Mode Global Config

7.13.8 show sntp

This command is used to display SNTP settings and status.

Format show sntp

Mode Privileged Exec

Last Update Time Time of last clock update.

Last Attempt Time Time of last transmit query (in unicast mode).

Last Attempt Status Status of the last SNTP request (in unicast mode) or unsolicited message (in broadcast mode).

Broadcast Count Current number of unsolicited broadcast messages that have been received and processed by the SNTP client since last reboot.

Multicast Count Current number of unsolicited multicast messages that have been received and processed by the SNTP client since last reboot

7.13.9 show sntp client

This command is used to display SNTP client settings.

Format show sntp client

Mode Privileged Exec

Client Supported Modes Supported SNTP Modes (Broadcast, Unicast, or Multicast).

SNTP Version The highest SNTP version the client supports

Port SNTP Client Port

Client Mode: Configured SNTP Client Mode

Poll Interval Poll interval value for SNTP clients in seconds as a power of two.

Poll Timeout Poll timeout value in seconds for SNTP clients.

Poll Retry Poll retry value for SNTP clients.

7.13.10 show sntp server

This command is used to display SNTP server settings and configured servers.

Format show sntp server

Mode Privileged Exec

Server IP Address IP Address of configured SNTP Server

Server Type Address Type of Server.

Server Stratum Claimed stratum of the server for the last received valid packet.

Server Reference ID Reference clock identifier of the server for the last received valid packet.
Server Mode SNTP Server mode.

Server Max Entries Total number of SNTP Servers allowed.

Server Current Entries Total number of SNTP configured.

For each configured server:

IP Address IP Address of configured SNTP Server.

Address Type Address Type of configured SNTP server.

Priority IP priority type of the configured server.

Version SNTP Version number of the server. The protocol version used to query the server in unicast mode.

Port Server Port Number

Last Attempt Time Last server attempt time for the specified server.

Last Attempt Status Last server attempt status for the server.

Total Unicast Requests Number of requests to the server.

Failed Unicast Requests Number of failed requests from server.

7.14 DHCP Server Commands

These commands configure the DHCP Server parameters and address pools. The commands are divided by functionality into these different groups:

- Configuration Commands are used to configure features and options of the switch. For every configuration command there is a show command that will display the configuration setting.
- Show commands are used to display switch settings, statistics and other information.
- Clear commands clear some or all of the settings to factory defaults.

7.14.1 *client-identifier*

This command specifies the unique identifier for a DHCP client. Unique-identifier is a valid notation in hexadecimal format. In some systems, such as Microsoft DHCP clients, the client identifier is required instead of hardware addresses. The unique-identifier is a concatenation of the media type and the MAC address. For example, the Microsoft client identifier for Ethernet address c819.2488.f177 is 01c8.1924.88f1.77 where 01 represents the Ethernet media type. Refer to the "Address Resolution Protocol Parameters" section of RFC 1700, Assigned Numbers for a list of media type codes.

Default None

Format `client-identifier <uniqueidentifier>`

Mode DHCP Pool Config

7.14.1.1 *no client-identifier*

This command deletes the client identifier.

Format `no client-identifier`

Mode DHCP Pool Config

7.14.2 *client-name*

This command specifies the name for a DHCP client. Name is a string consisting of standard ASCII characters.

Default None

Format `client-name <name>`

Mode DHCP Pool Config

7.14.2.1 *no client-name*

This command removes the client name.

Format `no client-name`

Mode DHCP Pool Config

7.14.3 *default-router*

This command specifies the default router list for a DHCP client. {*address1*, *address2*... *address8*} are valid IP addresses, each made up of four decimal bytes ranging from 0 to 255. IP address 0.0.0.0 is invalid.

Default None

Format `default-router <address1> [<address2>...<address8>]`

Mode DHCP Pool Config

7.14.3.1 *no default-router*

This command removes the default router list.

Format `no default-router`

Mode DHCP Pool Config

7.14.4 *dns-server*

This command specifies the IP servers available to a DHCP client. Address parameters are valid IP addresses; each made up of four decimal bytes ranging from 0 to 255. IP address 0.0.0.0 is invalid.

Default none

Format `dns-server <address1> [<address2>...<address8>]`

Mode DHCP Pool Config

7.14.4.1 *no dns-server*

This command removes the DNS Server list.

Format `no dns-server`

Mode DHCP Pool Config

7.14.5 *hardware-address*

This command specifies the hardware address of a DHCP client.

Hardware-address is the MAC address of the hardware platform of the client consisting of 6 bytes in dotted hexadecimal format.

Type indicates the protocol of the hardware platform. It is 1 for 10 MB Ethernet and 6 for IEEE 802.

Default ethernet

Format hardware-address <hardwareaddress> [type]

Mode DHCP Pool Config

7.14.5.1 no hardware-address

This command removes the hardware address of the DHCP client.

Format no hardware-address

Mode DHCP Pool Config

7.14.6 host

This command specifies the IP address and network mask for a manual binding to a DHCP client. Address and Mask are valid IP addresses; each made up of four decimal bytes ranging from 0 to 255. IP address 0.0.0.0 is invalid.

The prefix-length is an integer from 0 to 32

Default none

Format host <address> [mask | prefix-length]

Mode DHCP Pool Config

7.14.6.1 no host

This command removes the IP address of the DHCP client.

Format no host

Mode DHCP Pool Config

7.14.7 ip dhcp excluded-address

This command specifies the IP addresses that a DHCP server should not assign to DHCP clients. Low-address and high-address are valid IP addresses; each made up of four decimal bytes ranging from 0 to

255. IP address 0.0.0.0 is invalid.

Default none

Format ip dhcp excluded-address <lowaddress> [highaddress]

Mode Global Config

7.14.7.1 no ip dhcp excluded-address

This command removes the excluded IP addresses for a DHCP client. Low-address and high-address are valid IP addresses; each made up of four decimal bytes ranging from 0 to 255. IP address 0.0.0.0 is invalid.

Format no ip dhcp excluded-address <lowaddress> [highaddress]

Mode Global Config

7.14.8 ip dhcp ping packets

This command is used to specify the number, in a range from 2-10, of packets a DHCP server sends to a pool address as part of a ping operation. By default the number of packets sent to a pool address is 2(the smallest allowed number when sending packets). Setting the number of packets to 0 disables this command.

Note:The no form of this command sets the number of packets sent to a pool address to 0 and therefore prevents the server from pinging pool addresses.

Default 2

Format ip dhcp ping packets <0,2-10>

Mode Global Config

7.14.8.1 no ip dhcp ping packets

This command prevents the server from pinging pool addresses and sets the number of packets to 0.

Default 0

Format no ip dhcp ping packets

Mode Global Config

7.14.9 ip dhcp pool

This command configures a DHCP address pool name on a DHCP server and enters DHCP pool configuration mode.

Default none

Format ip dhcp pool <name>

Mode Global Config Mode

7.14.9.1 no ip dhcp pool

This command removes the DHCP address pool. The name should be previously configured pool name.

Format no ip dhcp pool <name>

Mode Global Config Mode

7.14.10 lease

This command configures the duration of the lease for an IP address that is assigned from a DHCP server to a DHCP client. The overall lease time should be between 1-86400 minutes. If *infinite* is specified, lease is set for 60 days. *Days* is an integer from 0 to 59. *Hours* is an integer from 0 to 1439. *Minutes* is an integer from 0 to 86399.

Default 1(day)

Format lease {[<days> [hours] [minutes]] | [infinite]}

Mode DHCP Pool Config

7.14.10.1 no lease

This command restores the default value of the lease time for DHCP Server.

Format no lease

Mode DHCP Pool Config

7.14.11 network

This command is used to configure the subnet number and mask for a DHCP address pool on the server. Network-number is a valid IP address, made up of four decimal bytes ranging from 0 to 255. IP address

0.0.0.0 is invalid. Mask is the IP subnet mask for the specified address pool. The prefix-length is an integer from 0 to 32.

Default none

Format network <networknumber> [mask | prefixlength]

Mode DHCP Pool Config

7.14.11.1 no network

This command removes the subnet number and mask.

Format no network

Mode DHCP Pool Config

7.14.12 service dhcp

This command enables the DHCP server and relay agent features on the router.

Default disabled

Format service dhcp

Mode Global Config

7.14.12.1 no service dhcp

This command disables the DHCP server and relay agent features.

Format no service dhcp

Mode Global Config

7.14.13 bootfile

The command specifies the name of the default boot image for a DHCP client. The <filename> specifies the boot image file.

Default none

Format bootfile <filename>

Mode DHCP Pool Config

7.14.13.1 no bootfile

This command deletes the boot image name.

Format no bootfile

Mode DHCP Pool Config

7.14.14 domain-name

This command specifies the domain name for a DHCP client. The <domain> specifies the domain name string of the client.

Default none

Format domain-name <domain>

Mode DHCP Pool Config

7.14.14.1 no domain-name

This command removes the domain name.

Format no domain-name

Mode DHCP Pool Config

7.14.15 ip dhcp bootp automatic

This command enables the allocation of the addresses to the bootp client. The addresses are from the automatic address pool.

Default disable

Format ip dhcp bootp automatic

Mode Global Config

7.14.15.1 no ip dhcp bootp automatic

This command disables the allocation of the addresses to the bootp client. The address are from the automatic address pool.

Format no ip dhcp bootp automatic

Mode Global Config

7.14.16 ip dhcp conflict logging

This command enables conflict logging on DHCP server.

Default enabled

Format ip dhcp conflict logging

Mode Global Config

7.14.16.1 no ip dhcp conflict logging

This command disables conflict logging on DHCP server.

Format no ip dhcp conflict logging

Mode Global Config

7.14.17 netbios-name-server

This command configures NetBIOS Windows Internet Naming Service (WINS) name servers that are available to DHCP clients. One IP address is required, although one can specify up to eight addresses in one command line. Servers are listed in order of preference (address1 is the most preferred server, address2 is the next most preferred server, and so on).

Default none

Format netbios-name-server <address> [<address2>...<address8>]

Mode DHCP Pool Config

7.14.17.1 *no netbios-name-server*

This command removes the NetBIOS name server list.

Format no netbios-name-server

Mode DHCP Pool Config

7.14.18 *netbios-node-type*

The command configures the NetBIOS node type for Microsoft Dynamic Host Configuration Protocol (DHCP) clients. Specifies the NetBIOS node type. Valid types are:

b-node—Broadcast

p-node—Peer-to-peer

m-node—Mixed

h-node—Hybrid (recommended)

Default none

Format netbios-node-type <type>

Mode DHCP Pool Config

7.14.18.1 *no netbios-node-type*

This command removes the NetBIOS node Type.

Format no netbios-node-type

Mode DHCP Pool Config

7.14.19 *next-server*

This command configures the next server in the boot process of a DHCP client.

Address is the IP address of the next server in the boot process, which is typically a Trivial File Transfer Protocol (TFTP) server.

Default If the *next-server* command is not used to configure a boot server list, the DHCP Server uses inbound interface helper addresses as boot servers.

Format next-server <address>

Mode DHCP Pool Config

7.14.19.1 *no next-server*

This command removes the boot server list.

Format no next-server

Mode DHCP Pool Config

7.14.20 option

The command configures DHCP Server options. *Code* specifies the DHCP option code. Ascii string specifies an NVT ASCII character string. ASCII character strings that contain white space must be delimited by quotation marks. Hex string specifies hexadecimal data. in hexadecimal character strings is two hexadecimal digits—each byte can be separated by a period, colon, or white space.

Example :a3:4f:22:0c / a3 4f 22 0c / a34f.220c.9fed The <address> specifies an IP address.

Default none

Format option <code> {ascii string | hex <string1> [<string2>...<string8>]
| ip <address1> [<address2>...<address8>]}

Mode DHCP Pool Config

7.14.20.1 no option

This command removes the options.

Format no option <code>

Mode DHCP Pool Config

7.14.21 show ip dhcp binding

This command displays address bindings for the specific IP address on the DHCP server. If no IP address is specified, the bindings corresponding to all the addresses are displayed.

Format show ip dhcp binding [address]

Modes Privileged EXEC User EXEC

IP address The IP address of the client.

Hardware Address The MAC Address or the client identifier.

Lease expiration The lease expiration time of the IP Address assigned to the client.

Type The manner in which IP Address was assigned to the client.

7.14.22 show ip dhcp global configuration

This command displays address bindings for the specific IP address on the DHCP server. If no IP address is specified, the bindings corresponding to all the addresses are displayed.

Format `show ip dhcp global configuration`

Modes Privileged EXEC User EXEC

Service DHCP The field to display the status of dhcp protocol.

Number of Ping Packets The maximum number of Ping Packets that will be sent to verify that an ip address id not already assigned.

Excluded Address The ranges of IP addresses that a DHCP server should not assign to DHCP clients.

7.14.23 show ip dhcp pool configuration

This command displays pool configuration. If **all** is specified, configuration for all the pools is displayed.

Format `show ip dhcp pool configuration {<name> | all}`

Modes Privileged EXEC User EXEC

Pool Name The name of the configured pool.

Pool Type The pool type.

Lease Time The lease expiration time of the IP Address assigned to the client.

DNS Servers The list of DNS servers available to the DHCP client

Default Routers The list of the default routers available to the DHCP client

Following additional field is displayed for Dynamic pool type:

Network The network number and the mask for the DHCP address pool. Following additional fields are displayed for Manual pool type:

Client Name The name of a DHCP client.

Client Identifier The unique identifier of a DHCP client.

Hardware Address The hardware address of a DHCP client.

Hardware Address Type The protocol of the hardware platform.

Host The IP address and the mask for a manual binding to a DHCP client.

7.14.24 show ip dhcp server statistics

This command displays DHCP server statistics.

Format `show ip dhcp server statistics`

Modes Privileged EXEC User EXEC

Address Pool The number of configured address pools in the DHCP server.

Automatic bindings The number of IP addresses that have been automatically mapped to the MAC addresses of hosts that are found in the DHCP database.

Manual bindings The number of IP addresses that have been manually mapped to the MAC addresses of hosts that are found in the DHCP database.

Expired bindings The number of expired leases.

Malformed messages The number of truncated or corrupted messages that were received by the DHCP server.

Message Received

DHCPREQUEST The number of DHCPREQUEST messages that were received by the server.

DHCPDECLINE The number of DHCPDECLINE messages that were received by the server.

DHCPRELEASE The number of DHCPRELEASE messages that were received by the server.

DHCPINFORM The number of DHCPINFORM messages that were received by the server.

Message Sent

DHCPOFFER The number of DHCPOFFER messages that were sent by the server.

DHCPACK The number of DHCPACK messages that were sent by the server.

DHC PNACK The number of DHC PNACK messages that were sent by the server.

7.14.25 show ip dhcp conflict

This command displays address conflicts logged by the DHCP Server. If no IP address is specified, all the conflicting addresses are displayed.

Format **show ip dhcp conflict [ip-address]**

Modes Privileged EXEC User EXEC

IP address The IP address of the host as recorded on the DHCP server.

Detection Method The manner in which the IP address of the hosts were found on the DHCP Server

Detection time The time when the conflict was found.

7.14.26 clear ip dhcp binding

This command deletes an automatic address binding from the DHCP server database. If "*" is specified, the bindings corresponding to all the addresses are deleted. <address> is a valid IP address made up of four decimal bytes ranging from 0 to 255. IP address 0.0.0.0 is invalid.

Default none

Format clear ip dhcp binding {address | *}

Mode Privileged EXEC

7.14.27 clear ip dhcp server statistics

This command clears DHCP server statistics counters.

Format clear ip dhcp server statistics

Mode Privileged EXEC

7.14.28 clear ip dhcp conflict

The command is used to clear an address conflict from the DHCP Server database. The server detects conflicts using a ping. DHCP server clears all conflicts If the asterisk (*) character is used as the address parameter.

Default none

Format clear ip dhcp conflict {<address> | *}

Mode Privileged EXEC

7.15 Double VLAN Commands

This chapter provides a detailed explanation of the Double VLAN (dvlan) commands. The commands are divided into two functional groups:

- Show commands display switch settings, statistics, and other information.
- Configuration commands configure features and options of the switch. For every configuration command, there is a show command that displays the configuration setting.

7.15.1 *dvlan-tunnel customer-id*

This command configures the customer identification for the Double VLAN tunnel on the specified interface. The customer ID may have the value 0 to 4095. The default value of the customer ID is 0.

Default 0

Format `dvlan-tunnel customer-id <0-4095>`

Mode Interface Config

7.15.1.1 *no dvlan-tunnel customer-id*

This command configures the customer identification for the Double VLAN tunnel on the specified interface to its default value.

Format `no dvlan-tunnel customer-id`

Mode Interface Config

7.15.2 *dvlan-tunnel etherType*

This command configures the ether-type for the specified interface. The ether-type may have the values of **802.1Q**, **vMAN**, or **custom**. If the ether-type has a value of **custom**, the optional value of the custom ether type must be set to a value from 0 to 65535.

Default vman

Format `dvlan-tunnel etherType <802.1Q / vman / custom> [0-65535]`

Mode Interface Config

7.15.2.1 *no dvlan-tunnel etherType*

This command configures the ether-type for the specified interface to its default value.

Format `no dvlan-tunnel etherType`

Mode Interface Config

7.15.3 mode dot1q-tunnel

This command is used to enable Double VLAN Tunneling on the specified interface. By default, Double VLAN Tunneling is disabled.

Default disabled

Format mode dot1q-tunnel

Mode Interface Config

7.15.3.1 no mode dot1q-tunnel

This command is used to disable Double VLAN Tunneling on the specified interface. By default, Double VLAN Tunneling is disabled.

Format no mode dot1q-tunnel

Mode Interface Config

7.15.4 mode dvlan-tunnel

This command is used to enable Double VLAN Tunneling on the specified interface. By default, Double VLAN Tunneling is disabled.

Default disabled

Format mode dvlan-tunnel

Mode Interface Config

7.15.4.1 no mode dvlan-tunnel

This command is used to disable Double VLAN Tunneling on the specified interface. By default, Double VLAN Tunneling is disabled.

Format no mode dvlan-tunnel

Mode Interface Config

7.15.5 show dot1q-tunnel

This command displays all interfaces enabled for Double VLAN Tunneling.

Format show dot1q-tunnel

Mode Privileged EXEC and User EXEC

Unit/Slot/Port Valid unit, slot and port number separated by forward slashes.

7.15.6 *show dot1q-tunnel interface*

This command displays detailed information about Double VLAN Tunneling for the specified interface.

Format `show dot1q-tunnel interface <unit/slot/port>`

Mode Privileged EXEC and User EXEC

Unit/Slot/Port Valid unit, slot and port number separated by forward slashes.

Mode This field specifies the administrative mode through which Double VLAN Tunneling can be enabled or disabled. The default value for this field is disabled.

Customer Id This is a 12-bit customer ID which will be used as the last 12 bits of the Double VLAN Tunnel. The valid range for a customer ID is 0 to 4095.

EtherType This field represents a 2-byte hex EtherType to be used as the first 16 bits of the DVLAN tunnel. There are three different EtherType tags. The first is 802.1Q, which represents the commonly used value of 0x8100. The second is vMAN, which represents the commonly used value of 0x88A8. If EtherType is not one of these two values, then it is a custom tunnel value, representing any value in the range of 0 to 65535.

7.15.7 *show dvlan-tunnel*

This command displays all interfaces enabled for Double VLAN Tunneling.

Format `show dvlan-tunnel`

Mode Privileged EXEC and User EXEC

Unit/Slot/Port Valid unit, slot and port number separated by forward slashes.

7.15.8 *show dvlan-tunnel interface*

This command displays detailed information about Double VLAN Tunneling for the specified interface.

Format `show dvlan-tunnel interface <unit/slot/port>`

Mode Privileged EXEC and User EXEC

Unit/Slot/Port Valid unit, slot and port number separated by forward slashes.

Mode This field specifies the administrative mode through which Double VLAN Tunneling can be enabled or disabled. The default value for this field is disabled.

Customer Id This is a 12-bit customer ID which will be used as the last 12 bits of the DVLAN Tunnel. The valid range for a customer ID is 0 to 4095.

EtherType This field represents a 2-byte hex EtherType to be used as the first 16 bits of the DVLAN tunnel. There are three different EtherType tags. The first is 802.1Q, which represents the commonly used value of 0x8100. The second is vMAN, which represents the commonly used value of 0x88A8. If EtherType is not one of these two values, then it is a custom tunnel value, representing any value in the range of 0 to 65535.

7.16 Provisioning (IEEE 802.1p) Commands

This chapter provides a detailed explanation of the Provisioning commands. The commands are divided into two functional groups:

- Show commands display switch settings, statistics, and other information.
- Configuration commands configure features and options of the switch. For every configuration command, there is a show command that displays the configuration setting.

7.16.1 *classofservice dot1pmapping*

This command maps an 802.1p priority to an internal traffic class for a device when in 'Global Config' mode. The number of available traffic classes may vary with the platform. Userpriority and trafficclass can both be the range from 0-7. The command is only available on platforms that support priority to traffic class mapping on a 'per-port' basis, and the number of available traffic classes may vary with the platform.

Format classofservice dot1pmapping <userpriority> <trafficclass>

Mode Global Config Interface Config

7.16.2 *show classofservice dot1pmapping*

This command displays the current 802.1p priority mapping to internal traffic classes for a specific interface. The unit/slot/port parameter is required on platforms that support priority to traffic class mapping on a 'per-port' basis.

Platforms that support priority to traffic class mapping on a per-port basis:

Format show classofservice dot1pmapping <unit/slot/port>

Platforms that do not support priority to traffic class mapping on a per-port basis:

Format Show classofservice dot1pmapping

Mode Privileged EXEC and User EXEC

7.16.3 *vlan port priority all*

This command configures the port priority assigned for untagged packets for all ports presently plugged into the device. The range for the priority is 0-7. Any subsequent per port configuration will override this configuration setting.

Format vlan port priority all <priority>

Mode Global Config

7.16.4 *vlan priority*

This command configures the default 802.1p port priority assigned for untagged packets for a specific interface. The range for the priority is 0-7

Default 0

Format vlan priority <*priority*>

Mode Interface Config

7.17 GARP Commands

This chapter provides a detailed explanation of the GARP commands. The commands are divided into two functional groups:

- Show commands display switch settings, statistics, and other information.
- Configuration commands configure features and options of the switch. For every configuration command, there is a show command that displays the configuration setting.

7.17.1 *set garp timer join*

This command sets the GVRP join time per port and per GARP. Join time is the interval between the transmission of GARP Protocol Data Units (PDUs) registering (or re-registering) membership for a VLAN or multicast group.

This command has an effect only when GVRP is enabled. The time is from 10 to 100 (centiseconds). the value 20 centiseconds is 0.2 seconds.

Default 20

Format set garp timer join <10-100>

Mode Interface Config

7.17.1.1 *no set garp timer join*

This command sets the GVRP join time per port and per GARP to 20 centiseconds (0.2 seconds). This command has an effect only when GVRP is enabled.

Format no set garp timer join

Mode Interface Config

7.17.2 *set garp timer leave*

This command sets the GVRP leave time per port. Leave time is the time to wait after receiving an unregister request for a VLAN or a multicast group before deleting the VLAN entry. This can be considered a buffer time for another station to assert registration for the same attribute in order to maintain uninterrupted service.time is 20 to 600 (centiseconds). The value 60 centiseconds is 0.6 seconds.

Note: *This command has an effect only when GVRP is enabled.*

Default 60

Format set garp timer leave <20-600>

Mode Interface Config

7.17.2.1 no set garp timer leave

This command sets the GVRP leave time per port to 60 centiseconds (0.6 seconds).

Note: *This command has an effect only when GVRP is enabled.*

Format no set garp timer leave

Mode Interface Config

7.17.3 set garp timer leaveall

This command sets how frequently *Leave All PDUs* are generated per port. A *Leave All PDU* indicates that all registrations will be unregistered. Participants would need to rejoin in order to maintain registration. The value applies per port and per GARP participation. The time may range from 200 to 6000 (centiseconds). The value 1000 centiseconds is 10 seconds.

Note: *This command has an effect only when GVRP is enabled.*

Default 1000

Format set garp timer leaveall <200-6000>

Mode Interface Config

7.17.3.1 no set garp timer leaveall

This command sets how frequently *Leave All PDUs* are generated per port to 1000 centiseconds (10 seconds).

Note: *This command has an effect only when GVRP is enabled.*

Format no set garp timer leaveall

Mode Interface Config

7.17.4 show garp

This command displays Generic Attributes Registration Protocol (GARP) information.

Format show garp

Mode Privileged EXEC and User EXEC

GMRP Admin Mode This displays the administrative mode of GARP Multicast Registration Protocol (GMRP) for the system.

GVRP Admin Mode This displays the administrative mode of GARP VLAN Registration Protocol (GVRP) for the system

7.18 GARP VLAN Registration Protocol (GVRP) Commands

This chapter provides a detailed explanation of the GVRP commands. The commands are divided into two functional groups:

- Show commands display switch settings, statistics, and other information.
- Configuration commands configure features and options of the switch. For every configuration command, there is a show command that displays the configuration setting.

7.18.1 *set gvrp*

This command sets GARP VLAN Registration Protocol parameters for all ports.

Default disabled

Format set gvrp

Mode Interface Config

7.18.1.1 *no set gvrp*

This command disables GARP VLAN Registration Protocol for all ports. If GVRP is disabled, Join Time, Leave Time and Leave All Time have no effect.

Format no set gvrp

Mode Interface Config

7.18.2 *set gvrp adminmode*

This command enables GVRP.

Default disabled

Format set gvrp adminmode

Mode Privileged EXEC

7.18.2.1 *no set gvrp adminmode*

This command disables GVRP.

Format no set gvrp adminmode

Mode Privileged EXEC

7.18.3 *set gvrp interfacemode*

This command enables GVRP (GARP VLAN Registration Protocol) for a specific port.

Default disabled

Format set gvrp interfacemode

Mode Interface Config

7.18.3.1 no set gvrp interfacemode

This command disables GVRP (GARP VLAN Registration Protocol) for a specific port. If GVRP is disabled, Join Time, Leave Time and Leave All Time have no effect.

Format no set gvrp interfacemode

Mode Interface Config

7.18.4 show gvrp configuration

This command displays Generic Attributes Registration Protocol (GARP) information for one or all interfaces.

Format show gvrp configuration {<unit/slot/port> / all}

Mode Privileged EXEC and User EXEC

Interface Valid unit, slot and port number separated by forward slashes.

Join Timer Specifies the interval between the transmission of GARP PDUs registering (or re-registering) membership for an attribute. Current attributes are a VLAN or multicast group. There is an instance of this timer on a per-Port, per-GARP participant basis. Permissible values are 10 to 100 centiseconds (0.1 to 1.0 seconds). The factory default is 20 centiseconds (0.2 seconds). The finest granularity of specification is 1 centisecond (0.01 seconds).

Leave Timer Specifies the period of time to wait after receiving an unregister request for an attribute before deleting the attribute. Current attributes are a VLAN or multicast group. This may be considered a buffer time for another station to assert registration for the same attribute in order to maintain uninterrupted service. There is an instance of this timer on a per-Port, per-GARP participant basis. Permissible values are 20 to 600 centiseconds (0.2 to 6.0 seconds). The factory default is 60 centiseconds (0.6 seconds). The finest granularity of specification is 1 centisecond (0.01 seconds).

LeaveAll Timer This Leave All Time controls how frequently LeaveAll PDUs are generated. A LeaveAll PDU indicates that all registrations will shortly be deregistered. Participants will need to rejoin in order to maintain registration. There is an instance of this timer on a per-Port, per-GARP participant basis. The Leave All Period Timer is set to a random value in the range of LeaveAll-Time to 1.5*LeaveAllTime. Permissible values are 200 to 6000 centiseconds (2 to 60 seconds). The factory default is 1000 centiseconds (10 seconds). The finest granularity of specification is 1 centisecond (0.01 seconds).

Port GMRP Mode Indicates the GMRP administrative mode for the port. It may be enabled or disabled. If this parameter is disabled, Join Time, Leave Time and Leave All Time have no effect. The factory default is disabled.

7.19 GARP Multicast Registration Protocol (GMRP) Commands

This chapter provides a detailed explanation of the GMRP commands. The commands are divided into two functional groups:

- Show commands display switch settings, statistics, and other information.
- Configuration commands configure features and options of the switch. For every configuration command, there is a show command that displays the configuration setting.

7.19.1 *set gmrp adminmode*

This command enables GARP Multicast Registration Protocol (GMRP) on the system. The default value is disable.

Format `set gmrp adminmode`

Mode Privileged EXEC

7.19.1.1 *no set gmrp adminmode*

This command disables GARP Multicast Registration Protocol (GMRP) on the system.

Format `no set gmrp adminmode`

Mode Privileged EXEC

7.19.2 *set gmrp interfacemode*

This command enables GARP Multicast Registration Protocol on a selected interface. If an interface which has GARP enabled is enabled for routing or is enlisted as a member of a port-channel (LAG), GARP functionality will be disabled on that interface. GARP functionality will subsequently be re-enabled if routing is disabled and port-channel (LAG) membership is removed from an interface that has GARP enabled.

Default disabled

Format `set gmrp interfacemode`

Mode Interface Config

7.19.2.1 *no set gmrp interfacemode*

This command disables GARP Multicast Registration Protocol on a selected interface. If an interface which has GARP enabled is enabled for routing or is enlisted as a member of a port-channel (LAG), GARP functionality will be disabled on that interface. GARP functionality will subsequently be re-enabled if routing is disabled and port-channel (LAG) membership is removed from an interface that has GARP enabled.

Format `no set gmrp interfacemode`

Mode Interface Config

7.19.3 *show gmrp configuration*

This command displays Generic Attributes Registration Protocol (GARP) information for one or all interfaces.

Format `show gmrp configuration {<unit/slot/port> | all}`

Mode Privileged EXEC and User EXEC

Interface This displays the unit/slot/port of the interface that this row in the table describes.

Join Timer Specifies the interval between the transmission of GARP PDUs registering (or re-registering) membership for an attribute. Current attributes are a VLAN or multicast group. There is an instance of this timer on a per-Port, per-GARP participant basis. Permissible values are 10 to 100 centiseconds (0.1 to 1.0 seconds). The factory default is 20 centiseconds (0.2 seconds). The finest granularity of specification is 1 centisecond (0.01 seconds).

Leave Timer Specifies the period of time to wait after receiving an unregister request for an attribute before deleting the attribute. Current attributes are a VLAN or multicast group. This may be considered a buffer time for another station to assert registration for the same attribute in order to maintain uninterrupted service. There is an instance of this timer on a per-Port, per-GARP participant basis. Permissible values are 20 to 600 centiseconds (0.2 to 6.0 seconds). The factory default is 60 centiseconds (0.6 seconds). The finest granularity of specification is 1 centisecond (0.01 seconds).

LeaveAll Timer This Leave All Time controls how frequently LeaveAll PDUs are generated. A LeaveAll PDU indicates that all registrations will shortly be deregistered. Participants will need to rejoin in order to maintain registration. There is an instance of this timer on a per-Port, per-GARP participant basis. The Leave All Period Timer is set to a random value in the range of LeaveAll-Time to 1.5*LeaveAllTime. Permissible values are 200 to 6000 centiseconds (2 to 60 seconds). The factory default is 1000 centiseconds (10 seconds). The finest granularity of specification is 1 centisecond (0.01 seconds).

Port GMRP Mode Indicates the GMRP administrative mode for the port. It may be enabled or disabled. If this parameter is disabled, Join Time, Leave Time and Leave All Time have no effect. The factory default is disabled.

7.19.4 *show mac-address-table gmrp*

This command displays the GARP Multicast Registration Protocol (GMRP) entries in the Multicast Forwarding Database (MFDB) table.

Format `show mac-address-table gmrp`

Mode Privileged EXEC

Mac Address A unicast MAC address for which the switch has forwarding and or filtering information. The format is 6 or 8 two-digit hexadecimal numbers that are separated by colons, for example 01:23:45:67:89:AB. In an IVL system the MAC address will be displayed as 8 bytes.

Type This displays the type of the entry. Static entries are those that are configured by the end user. Dynamic entries are added to the table as a result of a learning process or protocol.

Description The text description of this multicast table entry.

Interfaces The list of interfaces that are designated for forwarding (Fwd:) and filtering (Flt:).

7.20 IGMP Snooping Commands

This section provides a detailed explanation of the IGMP Snooping commands. The commands are divided into two functional groups:

- Show commands display spanning tree settings, statistics, and other information.
- Configuration Commands configure features and options of the switch. For every configuration
- To set the IGMP Group membership interval for the system, interfaces or VLAN see the
- To set the IGMP maximum response for an interface or VLAN see the □
- To set the Multicast Router Present Expiration time on an interface or VLAN see the

7.20.1 *set igmp*

This command enables IGMP Snooping on the system (Global Config Mode) or an interface (Interface Config Mode).

This command also enables IGMP snooping on a particular VLAN, and in turn enabling IGMP snooping on all interfaces participating in this VLAN.

If an interface which has IGMP Snooping enabled is enabled for routing or is enlisted as a member of a port-channel (LAG), IGMP Snooping functionality will be disabled on that interface. IGMP Snooping functionality will subsequently be re-enabled if routing is disabled or port-channel (LAG) membership is removed from an interface that has IGMP Snooping enabled.

Note: *The IGMP application supports the following:*

- Validation of the IP header checksum (as well as the IGMP header checksum) and discarding of the
- frame upon checksum error.
- Maintenance of the forwarding table entries based on the MAC address versus the IP address.
- Flooding of unregistered multicast data packets to all ports in the VLAN.

Default disabled

Format `set igmp<vlanId>`

Modes Global Config

Interface Config

Vlan Mode

7.20.1.1 *no set igmp*

This command disables IGMP Snooping on the system.

Format `no set igmp<vlanId>`

Modes Global Config

Interface Config

Vlan Mode

7.20.2 *set igmp fast-leave*

This command enables or disables IGMP Snooping fast-leave admin mode on a selected interface or VLAN. Enabling fast-leave allows the switch to immediately remove the layer 2 LAN interface from its forwarding table entry upon receiving an IGMP leave message for that multicast group without first sending out MAC-based general queries to the interface.

Fast-leave admin mode should be enabled only on VLANs where only one host is connected to each layer 2 LAN port, to prevent the inadvertent dropping of the other hosts that were connected to the same layer 2 LAN port but were still interested in receiving multicast traffic directed to that group. Also, fast-leave processing is supported only with IGMP version 2 hosts.

Default `disable`

Format `set igmp fast-leave<vlanId>`

Modes `Interface Config`
 `Vlan Mode`

7.20.2.1 *no set igmp fast-leave*

This command disables IGMP Snooping fast-leave admin mode on a selected interface.

Format `no set igmp fast-leave<vlanId>`

Modes `Interface Config`
 `Vlan Mode`

7.20.3 *show igmpsnooping*

This command displays IGMP Snooping information. Configured information is displayed whether or not IGMP Snooping is enabled.

Format `show igmpsnooping[<unit/slot/port> | <vlanId>]`

Mode `Privileged EXEC`

This display parameters when the optional arguments '`<unit/slot/port>`' or '`<vlanId>`' are not used are as follows:

Admin Mode This indicates whether or not IGMP Snooping is active on the switch.

Interfaces Enabled for IGMP Snooping This is the list of interfaces on which IGMP Snooping is enabled.

Multicast Control Frame Count This displays the number of multicast control frames that are processed by the CPU.

Data Frames Forwarded by the CPU This displays the number of data frames that are forwarded by the CPU.

VLANS Enabled for IGMP Snooping This is the list of VLANS on which IGMP Snooping is enabled.

Additional display parameters when the argument is '`unit/slot/port`' are as follows:

Interface Admin Mode This indicates whether or not IGMP Snooping is active on the interface.

Query Interval Time This displays the IGMP Query Interval Time. This is the amount of time a switch will wait for a report for a particular group on a particular interface before it sends a query on that interface. This value may be configured

Max Response Time This displays the amount of time the switch will wait after sending a query on an interface, participating in the VLAN, because it did not receive a report for a particular group on that interface. This value may be configured.

Multicast Router Present Expiration Time If a query is not received on an interface, participating in the VLAN, within this amount of time, the interface is removed from the list of interfaces with multicast routers attached. This value may be configured.

Additional display parameters when the argument is '<vlanId>' are as follows:

VLAN Admin Mode This indicates whether or not IGMP Snooping is active on the VLAN.

Fast Leave Mode This indicates whether or not IGMP Snooping Fast-leave is active on the VLAN.

Group Membership Interval Time The Group Membership Interval time is the amount of time in seconds that a switch will wait for a report from a particular group on a particular interface, which is participating in the VLAN, before deleting the interface from the entry. This value may be configured

7.20.4 *show igmpsnooping mrouter interface*

This command displays information about statically configured ports.

Format `show igmpsnooping mrouter interface <unit/slot/port>`

Mode Privileged EXEC

Slot/Port The port on which multicast router information is being displayed.

Multicast Router Attached This indicates whether or not multicast router is statically enabled on the interface.

VLAN ID The list of VLANs of which the interface is a member.

7.20.5 *show mac-address-table igmpsnooping*

This command displays the IGMP Snooping entries in the Multicast Forwarding Database (MFDB) table.

Format `show mac-address-table igmpsnooping`

Mode Privileged EXEC

Mac Address A multicast MAC address for which the switch has forwarding and or filtering information. The format is two-digit hexadecimal numbers that are separated by colons, for example 01:23:45:67:89:AB. In an IVL system the MAC address will be displayed as a MAC address and VLAN ID combination of 8 bytes.

Type This displays the type of the entry. Static entries are those that are configured by the end user. Dynamic entries are added to the table as a result of a learning process or protocol.

Description The text description of this multicast table entry.

Interfaces The list of interfaces that are designated for forwarding (Fwd:.) and filtering (Flt:).

7.21 Link Aggregation (LAG)/Port-Channel (802.3AD) Commands

This section provides a detailed explanation of the LAG commands. The LAG feature initially load balances traffic based upon the source and destination MAC address. If an ARP entry is learned on the LAG then the LAG is converted to load balance based upon source/destination IP address.

The commands are divided into two functional groups:

- Show commands display switch settings, statistics, and other information.
- Configuration commands configure features and options of the switch. For every configuration command, there is a show command that displays the configuration setting.

Note: Use the `clear port-channel` command to clear port channels.

Note: After a LAG is created, the user should assign the LAG VLAN membership. If VLAN membership is not assigned, the LAG may become a member of the management VLAN. This may result in learning and switching issues.

7.21.1 *port-channel staticcapability*

This command enables the support of port-channels (static link aggregations - LAGs) on the device. By default, the static capability for all port-channels is disabled.

Default disabled

Format `port-channel staticcapability`

Mode Global Config

7.21.1.1 *no port-channel staticcapability*

This command disables the support of static port-channels (link aggregations - LAGs) on the device.

Format `no port-channel staticcapability`

Mode Global Config

7.21.2 *port lacpmode all*

This command enables Link Aggregation Control Protocol (LACP) on all ports.

Format `port lacpmode all`

Mode Global Config

7.21.2.1 *no port lacpmode all*

This command disables Link Aggregation Control Protocol (LACP) on all ports.

Format no port lacpmode all

Mode Global Config

7.21.3 port-channel

This command configures a new port-channel (LAG) and generates a logical unit/slot/port number for the port-channel. The <name> field is a character string which allows the dash '-' character as well as alphanumeric characters. Display this number using the "show port-channel".

Note: Before including a port in a port-channel, set the port physical mode. See 'speed' command.

Format port-channel <name>

Mode Global Config

7.21.3.1 no port-channel

This command deletes a port-channel (LAG).

Format no port-channel {<logical unit/slot/port> / all}

Mode Global Config

7.21.4 port-channel adminmode all

This command enables a port-channel (LAG). The interface is a logical unit/slot/port for a configured port-channel. The option all sets every configured port-channel with the same administrative mode setting.

Format port-channel adminmode all

Mode Global Config

7.21.4.1 no port-channel adminmode

This command disables a port-channel (LAG). The interface is a logical unit/slot/port for a configured port-channel. The option all sets every configured port-channel with the same administrative mode setting.

Format no port-channel adminmode all

Mode Global Config

7.21.5 port-channel linktrap

This command enables link trap notifications for the port-channel (LAG). The interface is a logical unit/ slot/port for a configured port-channel. The option all sets every configured port-channel with

the same administrative mode setting.

Default enabled

Format port-channel linktrap {<logical unit/slot/port> / all}

Mode Global Config

7.21.5.1 no port-channel linktrap

This command disables link trap notifications for the port-channel (LAG). The interface is a logical unit, slot and port slot and port for a configured port-channel. The option **all** sets every configured port-channel with the same administrative mode setting.

Format no port-channel linktrap {<logical unit/slot/port> / all}

Mode GlobalConfig

7.21.6 port-channel name

This command defines a name for the port-channel (LAG). The interface is a logical unit/slot/port for a configured port-channel, and name is an alphanumeric string up to 15 characters. This command is used to modify the name that was associated with the port-channel when it was created.

Format port-channel name {<logical unit/slot/port> / all | <name>}

Mode Global Config

7.21.7 show port-channel brief

This command displays the static capability of all port-channels (LAGs) on the device as well as a summary of individual port-channels.

Format show port-channel brief

Mode Privileged EXEC and User EXEC

Static Capability This field displays whether or not the device has static capability enabled.

For each port-channel the following information is displayed:

Name This field displays the name of the port-channel.

Link State This field indicates whether the link is up or down.

Mbr Ports This field lists the ports that are members of this port-channel, in <unit/slot/port> notation.

Active Ports This field lists the ports that are actively participating in this port-channel.

7.21.8 *show port-channel*

This command displays an overview of all port-channels (LAGs) on the switch.

Format `show port-channel {<logical unit/slot/port> | all}`

Modes Privileged EXEC User EXEC

Logical unit/slot/port Valid unit, slot and port number separated by forward slashes.

Lag Name The name of this port-channel (LAG). You may enter any string of up to 15 alphanumeric characters.

Link State Indicates whether the Link is up or down.

Admin Mode May be enabled or disabled. The factory default is enabled.

Link Trap Mode This object determines whether or not to send a trap when link status changes. The factory default is enabled.

STP Mode The Spanning Tree Protocol Administrative Mode associated with the port or port-channel (LAG). The possible values are:

Disable - Spanning tree is disabled for this port.

Enable - Spanning tree is enabled for this port.

Mbr Ports A listing of the ports that are members of this port-channel (LAG), in unit/slot/port notation. There can be a maximum of eight ports assigned to a given port-channel (LAG).

Port Speed Speed of the port-channel port.

Type This field displays the status designating whether a particular port-channel (LAG) is statically or dynamically maintained.

Static - The port-channel is statically maintained.

Dynamic - The port-channel is dynamically maintained.

Active Ports This field lists the ports that are actively participating in the port-channel (LAG).

7.21.9 *show port-channel summary*

This command displays the static capability of all LAGs on the device as well as a summary of individual LAGs.

Format `show port-channel`

Mode Privileged EXEC

Static Capability whether the device has static capability enabled.

Port-channel/LAG Summary:

Lag Name The name of the lag.

Link State Indicates whether the Link is up or down.

Mbr Ports A listing of the ports that are members of this lag, in slot.port notation.

Active Ports A listing of ports that are actively participating in the LAG.

7.22 Spanning Tree (STP) Commands

This chapter provides a detailed explanation of the Spanning Tree commands. The commands are divided into two functional groups:

- Show commands display switch settings, statistics, and other information.
- Configuration commands configure features and options of the switch. For every configuration command, there is a show command that displays the configuration setting.

7.22.1 *spanning-tree*

This command sets the STP mode for a specific port-channel (LAG). This is the value specified for STP Mode on the Port Configuration Menu. 802.1D mode is the default.

The interface is a logical unit/slot/port for a configured port-channel. The **all** option sets all configured port-channels (LAGs) with the same option.

The mode is one of the following:

802.1d IEEE 802.1D-compliant STP mode is used

fast Fast STP mode is used

off STP is turned off

Format `spanning-tree {<logical unit/slot/port> | all | <off | 802.1d | fast>}`

Mode Global Config

7.22.2 *spanning-tree*

This command sets the spanning-tree operational mode to enabled.

Default disabled

Format `spanning-tree`

Mode Global Config

7.22.2.1 *no spanning-tree*

This command sets the spanning-tree operational mode to disabled. While disabled, the spanning-tree configuration is retained and can be changed, but is not activated.

Format `no spanning-tree`

Mode Global Config

7.22.3 *spanning-tree bpdumigrationcheck*

This command enables BPDU migration check on a given interface. The **all** option enables BPDU migration check on all interfaces.

Format `spanning-tree bpdumigrationcheck {<unit/slot/port> | all}`

Mode Global Config

7.22.3.1 *no spanning-tree bpdumigrationcheck*

This command disables BPDU migration check on a given interface. The **all** option disables BPDU migration check on all interfaces.

Format `no spanning-tree bpdumigrationcheck {<unit/slot/port> | all}`

Mode Global Config

7.22.4 *spanning-tree configuration name*

This command sets the Configuration Identifier Name for use in identifying the configuration that this switch is currently using. The <name> is a string of at most 32 characters.

Default The base MAC address displayed using hexadecimal notation as specified in IEEE 802 standard.

Format `spanning-tree configuration name <name>`

Mode Global Config

7.22.4.1 *no spanning-tree configuration name*

This command resets the Configuration Identifier Name to its default.

Format `no spanning-tree configuration name`

Mode Global Config

7.22.5 *spanning-tree configuration revision*

This command sets the Configuration Identifier Revision Level for use in identifying the configuration that this switch is currently using. The Configuration Identifier Revision Level is a number in the range of 0 to 65535.

Default 0

Format `spanning-tree configuration revision <0-65535>`

Mode Global Config

7.22.5.1 *no spanning-tree configuration revision*

This command sets the Configuration Identifier Revision Level for use in identifying the configuration that this switch is currently using to the default value, i.e. 0.

Format `no spanning-tree configuration revision`

Mode `Global Config`

7.22.6 *spanning-tree edgeport*

This command specifies that this port is an Edge Port within the common and internal spanning tree. This will allow this port to transition to Forwarding State without delay.

Format `spanning-tree edgeport`

Mode `Interface Config`

7.22.6.1 *no spanning-tree edgeport*

This command specifies that this port is not an Edge Port within the common and internal spanning tree.

Format `no spanning-tree edgeport`

Mode `Interface Config`

7.22.7 *spanning-tree forceversion*

This command sets the Force Protocol Version parameter to a new value. The Force Protocol Version can be one of the following:

- 802.1d - ST BPDUs are transmitted rather than MST BPDUs (IEEE 802.1d functionality supported)
- 802.1w - RST BPDUs are transmitted rather than MST BPDUs (IEEE 802.1w functionality supported)
- 802.1s - MST BPDUs are transmitted (IEEE 802.1s functionality supported)

Default `802.1s`

Format `spanning-tree forceversion <802.1d | 802.1w | 802.1s>`

Mode `Global Config`

7.22.7.1 *no spanning-tree forceversion*

This command sets the Force Protocol Version parameter to the default value, i.e. 802.1s.

Format `no spanning-tree forceversion`

Mode Global Config

7.22.8 spanning-tree forward-time

This command sets the Bridge Forward Delay parameter to a new value for the common and internal spanning tree. The forward-time value is in seconds within a range of 4 to 30, with the value being greater than or equal to "(Bridge Max Age / 2) + 1".

Default 15

Format spanning-tree forward-time <4-30>

Mode Global Config

7.22.8.1 no spanning-tree forward-time

This command sets the Bridge Forward Delay parameter for the common and internal spanning tree to the default value, i.e. 15.

Format no spanning-tree forward-time

Mode Global Config

7.22.9 spanning-tree hello-time

This command sets the Admin Hello Time parameter to a new value for the common and internal spanning tree. The hellotime <value> is in whole seconds within a range of 1 to 10 with the value being less than or equal to "(Bridge Max Age / 2) - 1".

Default 2

Format spanning-tree hello-time <1-10>

Mode Interface Config

7.22.9.1 no spanning-tree hello-time

This command sets the admin Hello Time parameter for the common and internal spanning tree to the default value.

Format no spanning-tree hello-time

Mode Interface Config

7.22.10 spanning-tree max-age

This command sets the Bridge Max Age parameter to a new value for the common and internal spanning tree. The max-age value is in seconds within a range of 6 to 40, with the value being less than or equal to "2 times (Bridge Forward Delay - 1)".

Default 20

Format spanning-tree max-age <6-40>

Mode Global Config

7.22.10.1 no spanning-tree max-age

This command sets the Bridge Max Age parameter for the common and internal spanning tree to the default value, i.e. 20.

Format no spanning-tree max-age

Mode Global Config

7.22.11 spanning-tree max-hops

This command sets the MSTP Max Hops parameter to a new value for the common and internal spanning tree. The max-hops value is a range from 1 to 127.

Default 20

Format spanning-tree max-hops <1-127>

Mode Global Config

7.22.11.1 no spanning-tree max-hops

This command sets the Bridge Max Hops parameter for the common and internal spanning tree to the default value.

Format no spanning-tree max-hops

Mode Global Config

7.22.12 spanning-tree mst instance

This command adds a multiple spanning tree instance to the switch. The instance <mstid> is a number within a range of 1 to 4094, that corresponds to the new instance ID to be added. The maximum number of multiple instances supported by the device is 4.

Format spanning-tree mst instance <mstid>

Mode Global Config

7.22.12.1 no spanning-tree mst instance

This command removes a multiple spanning tree instance from the switch and reallocates all VLANs allocated to the deleted instance to the common and internal spanning tree. The instance <mstid> is a number that corresponds to the desired existing multiple spanning tree instance to be removed.

Format no spanning-tree mst instance <mstid>

Mode Global Config

7.22.13 spanning-tree mst priority

This command sets the bridge priority for a specific multiple spanning tree instance. The instance <mstid> is a number that corresponds to the desired existing multiple spanning tree instance. The priority value is a number within a range of 0 to 61440 in increments of 4096.

If 0 (defined as the default CIST ID) is passed as the <mstid>, then this command sets the Bridge Priority parameter to a new value for the common and internal spanning tree. The bridge priority value again is a number within a range of 0 to 61440. The twelve least significant bits will be masked according to the 802.1s specification. This will cause the priority to be rounded down to the next lower valid priority.

Default 32768

Format spanning-tree mst priority <mstid> <0-61440>

Mode Global Config

7.22.13.1 no spanning-tree mst priority

This command sets the bridge priority for a specific multiple spanning tree instance to the default value,

i.e. 32768. The instance <mstid> is a number that corresponds to the desired existing multiple spanning tree instance.

If 0 (defined as the default CIST ID) is passed as the <mstid>, then this command sets the Bridge Priority parameter for the common and internal spanning tree to the default value, i.e. 32768.

Format spanning-tree mst priority <mstid>

Mode Global Config

7.22.14 spanning-tree mst vlan

This command adds an association between a multiple spanning tree instance and a VLAN. The VLAN will no longer be associated with the common and internal spanning tree. The instance <mstid> is a number that corresponds to the desired existing multiple spanning tree instance. The <vlanid> corresponds to an existing VLAN ID.

Format spanning-tree mst vlan <mstid> <vlanid>

Mode Global Config

7.22.14.1 no spanning-tree mst vlan

This command removes an association between a multiple spanning tree instance and a VLAN.

The VLAN will again be associated with the common and internal spanning tree. The instance <mstid> is a number that corresponds to the desired existing multiple spanning tree instance. The <vlanid> corresponds to an existing VLAN ID.

Format no spanning-tree mst vlan <mstid> <vlanid>

Mode Global Config

7.22.15 spanning-tree port mode

This command sets the Administrative Switch Port State for this port to enabled.

Default disabled

Format spanning-tree port mode

Mode Interface Config

7.22.15.1 no spanning-tree port mode

This command sets the Administrative Switch Port State for this port to disabled.

Format no spanning-tree port mode

Mode Interface Config

7.22.16 spanning-tree port mode all

This command sets the Administrative Switch Port State for all ports to enabled.

Default disabled

Format spanning-tree port mode all

Mode Global Config

7.22.16.1 no spanning-tree port mode all

This command sets the Administrative Switch Port State for all ports to disabled.

Format no spanning-tree port mode all

Mode Global Config

7.22.17 show spanning-tree

This command displays spanning tree settings for the common and internal spanning tree, when the optional parameter “brief” is not included in the command. The following details are displayed.

Format show spanning-tree <brief>

Mode Privileged EXEC
User EXEC

Bridge Priority Specifies the bridge priority for the Common and Internal Spanning tree (CST). The value lies between 0 and 61440. It is displayed in multiples of 4096.

Bridge Identifier The bridge identifier for the CST. It is made up using the bridge priority and the base MAC address of the bridge.

Time Since Topology Change Time in seconds.

Topology Change Count Number of times changed.

Topology Change Boolean value of the Topology Change parameter for the switch indicating if a topology change is in progress on any port assigned to the common and internal spanning tree.

Designated Root The bridge identifier of the root bridge. It is made up from the bridge priority and the base MAC address of the bridge.

Root Path Cost Value of the Root Path Cost parameter for the common and internal spanning tree.

Root Port Identifier Identifier of the port to access the Designated Root for the CST.

Root Port Max Age Derived value.

Root Port Bridge Forward Delay Derived value.

Hello Time Configured value of the parameter for the CST.

Bridge Hold Time Minimum time between transmission of Configuration Bridge Protocol Data Units (BPDUs)

Bridge Max Hops Bridge max-hops count for the device.

CST Regional Root Bridge Identifier of the CST Regional Root. It is made up using the bridge priority and the base MAC address of the bridge.

Regional Root Path Cost Path Cost to the CST Regional Root.

Associated FIDs List of forwarding database identifiers currently associated with this instance.

Associated VLANs List of VLAN IDs currently associated with this instance.

When the "brief" optional parameter is included, this command displays spanning tree settings for the bridge. In this case, the following details are displayed.

Bridge Priority Configured value.

Bridge Identifier The bridge identifier for the selected MST instance. It is made up using the bridge priority and the base MAC address of the bridge.

Bridge Max Age Configured value.

Bridge Max Hops Bridge max-hops count for the device.

Bridge Hello Time Configured value.

Bridge Forward Delay Configured value.

Bridge Hold Time Minimum time between transmission of Configuration Bridge Protocol Data Units (BPDUs)

7.22.18 show spanning-tree summary

This command displays spanning tree settings and parameters for the switch. The following details are displayed on execution of the command.

Format show spanning-tree summary

Modes Privileged EXEC

User EXEC

Spanning Tree Adminmode Enabled or disabled.

Spanning Tree Version Version of 802.1 currently supported (IEEE 802.1s, IEEE 802.1w, or IEEE 802.1d) based upon the Force Protocol Version parameter.

Configuration Name Identifier used to identify the configuration currently being used.

Configuration Revision Level Identifier used to identify the configuration currently being used.

Configuration Digest Key Identifier used to identify the configuration currently being used.

MST Instances List of all multiple spanning tree instances configured on the switch

7.22.19 show spanning-tree interface

This command displays the settings and parameters for a specific switch port within the common and internal spanning tree. The <unit/slot/port> is the desired switch port. The following details are displayed on execution of the command.

Format show spanning-tree interface <unit/slot/port>

Mode Privileged EXEC

User EXEC

Hello Time Admin hello time for this port.

Port mode Enabled or disabled.

Port Up Time Since Counters Last Cleared Time since port was reset, displayed in days, hours, minutes, and seconds.

STP BPDUs Transmitted Spanning Tree Protocol Bridge Protocol Data Units sent

STP BPDUs Received Spanning Tree Protocol Bridge Protocol Data Units received.

RST BPDUs Transmitted Rapid Spanning Tree Protocol Bridge Protocol Data

Units sent

RST BPDUs Received Rapid Spanning Tree Protocol Bridge Protocol Data
Units received.

MSTP BPDUs Transmitted Multiple Spanning Tree Protocol Bridge Protocol
Data Units sent

MSTP BPDUs Received Multiple Spanning Tree Protocol Bridge Protocol Data
Units received.

7.22.20 *show spanning-tree mst port detailed*

This command displays the detailed settings and parameters for a specific switch port within a particular multiple spanning tree instance. The instance <mstid> is a number that corresponds to the desired existing multiple spanning tree instance. The <unit/slot/port> is the desired switch port.

Format show spanning-tree mst port detailed <mstid> <unit/slot/port>

Mode Privileged EXEC
User EXEC

MST Instance ID The ID of the existing MST instance.

Port Identifier The port identifier for the specified port within the selected MST instance. It is made up from the port priority and the interface number of the port.

Port Priority The priority for a particular port within the selected MST instance. The port priority is displayed in multiples of 16.

Port Forwarding State Current spanning tree state of this port.

Port Role Each MST Bridge Port that is enabled is assigned a Port Role for each spanning tree. The port role is one of the following values: Root Port, Designated Port, Alternate Port, Backup Port, Master Port or Disabled Port

Auto-Calculate Port Path Cost This indicates whether auto calculation for port path cost is enabled.

Port Path Cost Configured value of the Internal Port Path Cost parameter.

Auto-Calculate External Port Path Cost This indicates whether auto calculation for external port path cost is enabled.

External Port Path Cost Configured value of the external Port Path Cost parameter.

Designated Root The Identifier of the designated root for this port.

Designated Port Cost Path Cost offered to the LAN by the Designated Port

Designated Bridge Bridge Identifier of the bridge with the Designated Port.

Designated Port Identifier Port on the Designated Bridge that offers the lowest cost to the LAN.

If 0 (defined as the default CIST ID) is passed as the <mstid>, then this command displays the settings and parameters for a specific switch port within the common and internal spanning tree. The <unit/slot/port> is the desired switch port. In this case, the following are displayed.

Port Identifier The port identifier for this port within the CST.

Port Priority The priority of the port within the CST.

Port Forwarding State The forwarding state of the port within the CST.

Port Role The role of the specified interface within the CST.

Port Path Cost The configured path cost for the specified interface.

Designated Root Identifier of the designated root for this port within the CST.

Designated Port Cost Path Cost offered to the LAN by the Designated Port.

Designated Bridge The bridge containing the designated port

Designated Port Identifier Port on the Designated Bridge that offers the lowest cost to the LAN

Topology Change Acknowledgement Value of flag in next Configuration Bridge Protocol Data Unit (BPDU) transmission indicating if a topology change is in progress for this port.

Hello Time The hello time in use for this port.

Edge Port The configured value indicating if this port is an edge port.

Edge Port Status The derived value of the edge port status. True if operating as an edge port; false otherwise.

Point To Point MAC Status Derived value indicating if this port is part of a point to point link.

CST Regional Root The regional root identifier in use for this port.

CST Port Cost The configured path cost for this port.

7.22.21 show spanning-tree mst port summary

This command displays the settings of one or all ports within the specified multiple spanning tree instance. The parameter <mstid> indicates a particular MST instance. The parameter {<unit/slot/port> | all} indicates the desired switch port or all ports.

If 0 (defined as the default CIST ID) is passed as the <mstid>, then the status summary is displayed for one or all ports within the common and internal spanning tree.

Format show spanning-tree mst port summary <mstid> {<unit/slot/port> | all}

Modes Privileged EXEC

User EXEC

MST Instance ID The MST instance associated with this port.

Unit/Slot/Port Valid unit, slot and port number separated by forward slashes.

Type Currently not used.

STP State The forwarding state of the port in the specified spanning tree instance

Port Role The role of the specified port within the spanning tree.

Link Status The operational status of the link. Possible values are "Up" or "Down".

Link Trap The link trap configuration for the specified interface.

7.22.22 *show spanning-tree mst summary*

This command displays summary information about all multiple spanning tree instances in the switch. On execution, the following details are displayed.

Format `show spanning-tree mst summary`

Modes Privileged EXEC

User EXEC

MST Instance ID List List of multiple spanning trees IDs currently configured.

For each MSTID:

Associated FIDs List of forwarding database identifiers associated with this instance.

Associated VLANs List of VLAN IDs associated with this instance.

7.22.23 *show spanning-tree vlan*

This command displays the association between a VLAN and a multiple spanning tree instance. The <vlanid> corresponds to an existing VLAN ID.

Format `show spanning-tree vlan <vlanid>`

Modes Privileged EXEC

User EXEC

VLAN Identifier The VLANs associated with the selected MST instance.

Associated Instance Identifier for the associated multiple spanning tree instance or "CST" if associated with the common and internal spanning tree.

7.23 Bootp/DHCP Relay Commands

This chapter provides a detailed explanation of the BootP/DHCP Relay commands. The commands are divided by functionality into the following different groups:

- Show commands are used to display switch settings, statistics and other information.
- Configuration Commands are used to configure features and options of the switch. For every configuration command there is a show command that will display the configuration setting.
- Copy commands are used to transfer configuration and informational files to and from the switch.

7.23.1 *bootpdhcprelay cidoptmode*

This command enables the circuit ID option mode for BootP/DHCP Relay on the system.

Default disabled

Format `bootpdhcprelay cidoptmode`

Mode Global Config

7.23.1.1 *no bootpdhcprelay cidoptmode*

This command disables the circuit ID option mode for BootP/DHCP Relay on the system.

Format `no bootpdhcprelay cidoptmode`

Mode Global Config

7.23.2 *bootpdhcprelay enable*

This command enables the forwarding of relay requests for BootP/DHCP Relay on the system.

Default disabled

Format `bootpdhcprelay enable`

Mode Global Config

7.23.2.1 *no bootpdhcprelay enable*

This command disables the forwarding of relay requests for BootP/DHCP Relay on the system.

Format `no bootpdhcprelay enable`

Mode Global Config

7.23.3 *bootpdhcprelay maxhopcount*

This command configures the maximum allowable relay agent hops for BootP/DHCP Relay on the system. The <hops> parameter has a range of 1 to 16.

Default 4

Format `bootpdhcprelay maxhopcount <1-16>`

Mode Global Config

7.23.3.1 *no bootpdhcrelay maxhopcount*

This command configures the default maximum allowable relay agent hops for BootP/DHCP Relay on the system.

Format `no bootpdhcrelay maxhopcount`

Mode `Global Config`

7.23.4 *bootpdhcrelay minwaittime*

This command configures the minimum wait time in seconds for BootP/DHCP Relay on the system. When the BOOTP relay agent receives a BOOTREQUEST message, it MAY use the seconds-sinceclient-began-booting field of the request as a factor in deciding whether to relay the request or not. The parameter has a range of 0 to 100 seconds.

Default `0`

Format `bootpdhcrelay minwaittime <0-100>`

Mode `Global Config`

7.23.4.1 *no bootpdhcrelay minwaittime*

This command configures the default minimum wait time in seconds for BootP/DHCP Relay on the system.

Format `no bootpdhcrelay minwaittime`

Mode `Global Config`

7.23.5 *bootpdhcrelay serverip*

This command configures the server IP Address for BootP/DHCP Relay on the system. The <ipaddr> parameter is an IP address in a 4-digit dotted decimal format.

Default `0.0.0.0`

Format `bootpdhcrelay serverip <ipaddr>`

Mode `Global Config`

7.23.5.1 *no bootpdhcrelay serverip*

This command configures the default server IP Address for BootP/DHCP Relay on the system.

Format `no bootpdhcrelay serverip`

Mode `Global Config`

7.23.6 *show bootpdhcprelay*

This command displays the BootP/DHCP Relay information.

Format **show bootpdhcprelay**

Modes **Privileged EXEC User EXEC**

Maximum Hop Count Is the maximum allowable relay agent hops.

Minimum Wait Time (Seconds) Is the minimum wait time.

Admin Mode Represents whether relaying of requests is enabled or disabled.

Server IP Address Is the IP Address for the BootP/DHCP Relay server.

Circuit Id Option Mode Is the DHCP circuit Id option which may be enabled or disabled.

Requests Received Is the number of requests received.

Requests Relayed Is the number of requests relayed.

Packets Discarded Is the number of packets discarded.

7.24 Loopback Detection Commands

Loopback detection can be enabled to find a loopback on the port. If the loopback detection is enable and loopback is found on a interface system will disable the interface administratively. System will check periodically if the loopback still exists. Spanning-tree protocol must be enabled on the switch for loopback detection fearture.

7.24.1 loopback-detection enable all

This command enables the loopback detection on all ports.

Default disabled

Format loopback-detection enable all

Mode Global Config

7.24.1.1 no loopback-detection enable all

This command disables the loopback detection on all ports.

Format no loopback-detection enable all

Mode Global Config

7.24.2 loopback-detection enable

This command enables the loopback detection on a port.

Default disabled

Format loopback-detection enable

Mode Interface Config

7.23.1.1 no loopback-detection enable

This command disables the loopback detection on a port.

Format no loopback-detection enable

Mode Global Config

7.24.3 loopback-detection interval <5-60>

This command sets the loopback detection interval from 5 to 60(sec).

Default 30

Format loopback-detection interval <5-60>

Mode Global Config

7.23.1.1 no bootpdhcrelay cidoptmode

This command resets the loopback detection interval to default value, 30(sec).

Format no loopback-detection interval

Mode Global Config

7.24.4 show loopback-detection

This command displays the configuration and status of the loopback detection.

Format show loopback-detection {<unit/slot/port> | all}

Modes Privileged EXEC

8.0 Security Commands

This section provides a detailed explanation of the Security commands. The commands are divided into the following groups:

- Configuration commands are used to configure features and options of the switch. For every configuration command there is a show command that will display the configuration setting.
- Show commands are used to display switch settings, statistics and other information.

8.1 Port Security Commands

This section provides a detailed explanation of the Port Security commands. The commands are divided into the following groups:

- Configuration commands are used to configure features and options of the switch. For every configuration command there is a show command that will display the configuration setting.
- Show commands are used to display switch settings, statistics and other information.

8.1.1 *port-security*

This command enables port locking at the system level (Global Config) or port level (Interface Config)

Default	Disabled
Format	port-security
Modes	Global Config Interface Config

8.1.1.1 *no port-security*

This command disables port locking at the system level (Global Config) or port level (Interface Config).

Format	no port-security
Modes	Global Config Interface Config

8.1.2 *port-security deny*

This command enables port locking at interface level in deny mode.

Default	Disabled.
Format	port-security deny
Modes	Interface Config

8.1.2.1 *no port-security deny*

This command disables port locking at the interface level in deny mode.

Format no port-security deny
Modes Interface Config

8.1.3 port-security allow

This command enables port locking at interface level in allow mode.

Default Disabled
Format port-security allow
Modes Interface Config

8.1.3.1 no port-security allow

This command disables port locking at the interface level in allow mode.

Format no port-security allow
Modes Interface Config

8.1.4 port-security cpu-multicast-rate-limit

This command limits the CPU multicast rate on all the ports.

Format port-security cpu-multicast-rate-limit
Mode Interface config

8.1.5 port-security max-dynamic

This command sets the maximum of dynamically locked MAC addresses allowed on a specific port.

Default 600
Format port-security max-dynamic <maxvalue>
Mode Interface Config

8.1.5.1 no port-security max-dynamic

This command resets the maximum of dynamically locked MAC addresses allowed on a specific port to its default value.

Format no port-security max-dynamic
Mode Interface Config

8.1.6 port-security max-static

This command sets the maximum number of statically locked MAC addresses allowed on a specific port.

Default 20

Format port-security max-static <maxvalue>
Mode Interface Config

8.1.6.1 no port-security max-static

This command resets the maximum of statically locked MAC addresses allowed on a specific port to its default value.

Format no port-security max-static
Mode Interface Config

8.1.7 port-security max-static allow

This command sets the maximum number of statically locked MAC addresses allowed on a specific port.

Default 64.
Format port-security max-static allow <maxvalue>
Modes Interface Config

8.1.7 no port-security max-static allow

This command resets the maximum of statically locked MAC addresses allowed on a specific port to its default value.

Format no port-security max-static allow
Modes Interface Config

8.1.8 port-security max-static deny

This command sets the maximum number of statically locked MAC addresses denied on a specific port.

Default 64.
Format port-security max-static deny <maxvalue>
Modes Interface Config

8.1.8 no port-security max-static deny

This command resets the maximum of statically locked MAC addresses denied on a specific port to its default value.

Format no port-security allow
Modes Interface Config

8.1.9 port-security mac-address

This command adds a MAC address to the list of statically locked MAC addresses in allow or deny modes.

Format port-security mac-address <vid> <mac-address> {allow | deny}

Modes Interface Config

8.1.9.1 no port-security mac-address

This command removes a MAC address to the list of statically locked MAC addresses in allow or deny modes.

Format no port-security mac-address <vid> <mac-address> {allow | deny}

Modes Interface Config

8.1.10 port-security mac-address move

This command converts a dynamically locked MAC address to a statically locked address in allow mode.

Format port-security mac-address move <vid> <mac-address>

Modes Interface Config

8.1.11 snmp-server enable traps violation

This command enables the sending of new violation traps designating when a packet with a disallowed MAC address is received on a locked port.

Default Disabled

Format snmp-server enable traps violation

Mode Interface Config

8.1.11.1 no snmp-server enable traps violation

This command disables the sending of new violation traps.

Format no snmp-server enable traps violation

Mode Interface Config

8.1.12 show port-security

This command displays the port-security settings for the entire system.

Format show port-security

Mode Privileged EXEC

Admin Mode Port Locking mode for the entire system

8.1.13 show port-security <interface | all>

This command displays the port-security settings for a particular interface or all interfaces.

Format show port-security <interface | all>

Mode Privileged EXEC

Intf Indicates the interface.

Admin Mode Port Locking mode for the Interface.

Dynamic Limit Maximum dynamically allocated MAC Addresses.

Static Limit Maximum statically allocated MAC Addresses.

Violation Trap Mode Whether violation traps are enabled.

Allow Mode Port Locking mode for the entire system.

8.1.14 show port-security allow

This command displays the port-security allow settings for a particular interface or all interfaces.

Format show port-security allow <interface | all>

Modes Privileged EXEC

Intf Indicates the interface.

Interface Admin Mode Port Locking mode for the Interface

Dynamic Limit Maximum dynamically allocated MAC Addresses

Static Limit Maximum statically allocated MAC Addresses

Allow mode Allow mode is Enabled/Disabled

8.1.15 show port-security deny

This command displays the port-security information for all interfaces for DENY case.

Format show port-security deny <interface | all>

Mode Privileged EXEC

Intf Indicates the interface.

Interface Admin Mode Port Locking mode for the Interface.

Dynamic Limit Maximum dynamically allocated MAC Addresses.

Static Limit Maximum statically allocated MAC Addresses.

Violation Trap Mode Whether violation traps are enabled.

Allow Mode Deny mode is Enabled/Disabled.

8.1.16 show port-security dynamic

This command displays the dynamically locked MAC addresses for port.

Format show port-security dynamic <interface>

Mode Privileged EXEC
MAC Address MAC Address of dynamically locked MAC.

Intf Indicates the interface.

Admin Mode Port Locking mode for the Interface.

Dynamic Limit Maximum dynamically allocated MAC Addresses.

Static Limit Maximum statically allocated MAC Addresses.

Violation Trap Mode Whether violation traps are enabled.

Allow Mode Deny mode is Enabled/Disabled.

8.1.17 show port-security static

This command displays the statically locked MAC addresses for port.

Format show port-security static <interface>

Mode Privileged EXEC

MAC Address MAC Address of statically locked MAC.

Intf Indicates the interface.

Admin Mode Port Locking mode for the Interface.

Dynamic Limit Maximum dynamically allocated MAC Addresses.

Static Limit Maximum statically allocated MAC Addresses.

Violation Trap Mode Whether violation traps are enabled.

Allow Mode Deny mode is Enabled/Disabled.

8.1.18 show port-security static allow

This command displays the statically locked allow MAC addresses for port.

Format show port-security static <interface>

Mode Privileged EXEC

8.1.19 show port-security static deny

This command displays the statically locked deny MAC addresses for port.

Format show port-security static <interface>

Mode Privileged EXEC

8.1.20 show port-security violation

This command displays the source MAC address of the last packet that was discarded on a locked port.

Format show port-security violation <interface>

Mode Privileged EXEC

MAC Address MAC Address of discarded packet on locked port.

8.1.21 show port-security cpu-multicast-rate-limit

This command displays the CPU multicast rate on all the ports.

Format show port-security cpu-multicast-rate-limit

Mode Privileged EXEC

Intf Indicates the interface.

Admin Mode Port Locking mode for the Interface.

Dynamic Limit Maximum dynamically allocated MAC Addresses.

Static Limit Maximum statically allocated MAC Addresses.

Violation Trap Mode Whether violation traps are enabled.

Allow Mode Deny mode is Enabled/Disabled

8.2 Port Based Network Access Control (IEEE 802.1X) Commands

This section provides a detailed explanation of the 802.1x commands. The commands are divided into the following groups:

- Configuration commands are used to configure features and options of the switch. For every configuration command there is a show command that will display the configuration setting.
- Show commands are used to display switch settings, statistics and other information.

8.2.1 authentication login

This command creates an authentication login list. The <listname> is any character string and is not case sensitive. Up to 10 authentication login lists can be configured on the switch. When a list is created, the authentication method “local” is set as the first method.

When the optional parameters “Option1”, “Option2” and/or “Option3” are used, an ordered list of methods are set in the authentication login list. If the authentication login list does not exist, a new authentication login list is first created and then the authentication methods are set in the authentication login list. The maximum number of authentication login methods is three. The possible method values are **local**, **radius** and **reject**.

The value of **local** indicates that the user’s locally stored ID and password are used for authentication. The value of **radius** indicates that the user’s ID and password will be authenticated using the RADIUS server. The value of **reject** indicates the user is never authenticated.

To authenticate a user, the authentication methods in the user’s login will be attempted in order until an authentication attempt succeeds or fails.

Note: *The default login list included with the default configuration can not be changed.*

Format authentication login <listname> [method1 [method2 [method3]]]

Mode Global Config

8.2.1.1 no authentication login

This command deletes the specified authentication login list. The attempt to delete will fail if any of the following conditions are true:

- The login list name is invalid or does not match an existing authentication login list
- The specified authentication login list is assigned to any user or to the non configured user for any component
- The login list is the default login list included with the default configuration and was not created using ‘authentication login’. The default login list cannot be deleted.

Format no authentication login <listname>

Mode Global Config

8.2.2 clear dot1x statistics

This command resets the 802.1x statistics for the specified port or for all ports.

Format clear dot1x statistics { <unit/slot/port> | all }
Mode Privileged EXEC

8.2.3 clear radius statistics

This command is used to clear all RADIUS statistics.

Format clear radius statistics
Mode Privileged EXEC

8.2.4 dot1x defaultlogin

This command assigns the authentication login list to use for non-configured users for 802.1x port security. This setting is over-ridden by the authentication login list assigned to a specific user if the user is configured locally. If this value is not configured, users will be authenticated using local authentication only.

Format dot1x defaultlogin <listname>
Mode Global Config

8.2.5 dot1x initialize

This command begins the initialization sequence on the specified port. This command is only valid if the control mode for the specified port is 'auto'. If the control mode is not 'auto' an error will be returned.

Format dot1x initialize <unit/slot/port>
Mode Privileged EXEC

8.2.6 dot1x login

This command assigns the specified authentication login list to the specified user for 802.1x port security. The <user> parameter must be a configured user and the <listname> parameter must be a configured authentication login list.

Format dot1x login <user> <listname>
Mode Global Config

8.2.7 dot1x max-req

This command sets the maximum number of times the authenticator state machine on this port will transmit an EAPOL EAP Request/Identity frame before timing out the supplicant. The <count> value must be in the range 1 - 10.

Default 2
Format dot1x max-req <count>
Mode Interface Config

8.2.7.1 no dot1x max-req

This command sets the maximum number of times the authenticator state machine on this port will transmit an EAPOL EAP Request/Identity frame before timing out the supplicant.

Format no dot1x max-req
Mode Interface Config

8.2.8 dot1x port-control

This command sets the authentication mode to be used on the specified port. . The control mode may be one of the following.

force-unauthorize:

The authenticator PAE unconditionally sets the controlled port to unauthorized.

force-authorized: The authenticator PAE unconditionally sets the controlled port to authorized.

auto: The authenticator PAE sets the controlled port mode to reflect the outcome of the authentication exchanges between the supplicant, authenticator and the authentication server.

Default auto
Format dot1x port-control {force-unauthorized | force-authorized | auto}
Mode Interface Config

8.2.8.1 no dot1x port-control

This command sets the authentication mode to be used on the specified port to 'auto'.

Format no dot1x port-control
Mode Interface Config

8.2.9 dot1x port-control All

This command sets the authentication mode to be used on all ports. The control mode may be one of the following.

force-unauthorized: The authenticator PAE unconditionally sets the controlled port to unauthorized.

force-authorized: The authenticator PAE unconditionally sets the controlled port to authorized.

auto: The authenticator PAE sets the controlled port mode to reflect the outcome of the authentication exchanges between the supplicant, authenticator and the authentication server.

Default auto
Format dot1x port-control all {force-unauthorized | force-authorized | auto}
Mode Global Config

8.2.9.1 no dot1x port-control All

This command sets the authentication mode to be used on all ports to 'auto'.

Format no dot1x port-control all
Mode Global Config

8.2.10 dot1x re-authenticate

This command begins the re-authentication sequence on the specified port. This command is only valid if the control mode for the specified port is 'auto'. If the control mode is not 'auto' an error will be returned.

Format dot1x re-authenticate <unit/slot/port>

Mode Privileged EXEC

8.2.11 dot1x re-authentication

This command enables re-authentication of the supplicant for the specified port.

Default disabled

Format dot1x re-authentication

Mode Interface Config

8.2.11.1 no dot1x re-authentication

This command disables re-authentication of the supplicant for the specified port.

Format no dot1x re-authentication

Mode Interface Config

8.2.12 dot1x system-auth-control

This command is used to enable the dot1x authentication support on the switch. By default, the authentication support is disabled. While disabled, the dot1x configuration is retained and can be changed, but is not activated.

Default disabled

Format dot1x system-auth-control

Mode Global Config

8.2.12.1 no dot1x system-auth-control

This command is used to disable the dot1x authentication support on the switch.

Format no dot1x system-auth-control

Mode Global Config

8.2.13 dot1x timeout

This command sets the value, in seconds, of the timer used by the authenticator state machine on this port. Depending on the token used and the value (in seconds) passed, various timeout configurable parameters are set. The following tokens are supported.

reauth-period: Sets the value, in seconds, of the timer used by the authenticator state machine on this port to determine when re-authentication of the supplicant takes place. The reauth-period must be a value in the range 1 - 65535.

quiet-period: Sets the value, in seconds, of the timer used by the authenticator state machine on this port to define periods of time in which it will not attempt to acquire a supplicant. The quiet-period must be a value in the range 0 - 65535.

tx-period: Sets the value, in seconds, of the timer used by the authenticator state machine on this port to determine when to send an EAPOL EAP Request/Identity frame to the supplicant. The quiet-period must be a value in the range 1 - 65535.

supp-timeout: Sets the value, in seconds, of the timer used by the authenticator state machine on this port to timeout the supplicant. The supp-timeout must be a value in the range 1 - 65535.

server-timeout: Sets the value, in seconds, of the timer used by the authenticator state machine on this port to timeout the authentication server. The supp-timeout must be a value in the range 1 - 65535.

Default reauth-period: 3600 seconds
 rquiet-period: 60 seconds
 tx-period: 30 seconds
 supp-timeout: 30 seconds
 server-timeout: 30 seconds

Format t1x timeout {{reauth-period <seconds>} | {quiet-period <seconds>} | {tx-period <seconds>} | {supp-timeout <seconds>} | {server-timeout <seconds>}}

Mode Interface Config

8.2.13.1 no dot1x timeout

This command sets the value, in seconds, of the timer used by the authenticator state machine on this port to the default values. Depending on the token used, the corresponding default values are set.

Format dot1x timeout {reauth-period | quiet-period | tx-period | supp-timeout | server-timeout}

Mode Interface Config

8.2.14 dot1x user

This command adds the specified user to the list of users with access to the specified port or all ports. The <user> parameter must be a configured user.

Format dot1x user <user> {<unit/slot/port> | all}

Mode Global Config

8.2.14.1 no dot1x user

This command removes the user from the list of users with access to the specified port or all ports.

Format no dot1x user <user> {<unit/slot/port> | all}

Mode Global Config

8.2.15 dot1x port-method macbased

This command sets the authentication mode based on MAC address.

Format dot1x port-method macbased

Mode interface Config

8.2.15.1 *no dot1x port-method macbased*

This command removes the authentication mode based on MAC address.

Format no dot1x port-method macbased

Mode interface Config

8.2.16 *dot1x port-method portbased*

This command sets the authentication mode based on interface number.

Format dot1x port-method portbased

Mode interface Config

8.2.16.1 *no dot1x port-method portbased*

This command removes the authentication mode based on interface number.

Format no dot1x port-method portbased

Mode interface Config

8.2.17 *show radius accounting*

This command is used to display the configured RADIUS accounting mode, accounting server and the statistics for the configured accounting server.

Format show radius accounting [statistics <ipaddr>]

Mode Privileged EXEC

If the optional token 'statistics <ipaddr>' is not included, then only the accounting mode and the RADIUS accounting server details are displayed.

Mode Enabled or disabled

IP Address The configured IP address of the RADIUS accounting server

Port The port in use by the RADIUS accounting server

Secret Configured Yes or No

If the optional token 'statistics <ipaddr>' is included, the statistics for the configured RADIUS accounting server are displayed. The IP address parameter must match that of a previously configured RADIUS accounting server. The following information regarding the statistics of the RADIUS accounting server is displayed.

Accounting Server IP Address IP Address of the configured RADIUS accounting server

Round Trip Time The time interval, in hundredths of a second, between the most recent

Accounting-Response and the Accounting-Request that matched it from the RADIUS accounting server.

Requests The number of RADIUS Accounting-Request packets sent to this accounting server. This number does not include retransmissions.

Retransmission The number of RADIUS Accounting-Request packets retransmitted to this RADIUS accounting server.

Responses The number of RADIUS packets received on the accounting port from this server.

Malformed Responses The number of malformed RADIUS Accounting-Response packets received from this server. Malformed packets include packets with an invalid length. Bad authenticators and unknown types are not included as malformed accounting responses.

Bad Authenticators The number of RADIUS Accounting-Response packets containing invalid authenticators received from this accounting server.

Pending Requests The number of RADIUS Accounting-Request packets sent to this server that have not yet timed out or received a response.

Timeouts The number of accounting timeouts to this server.

Unknown Types The number of RADIUS packets of unknown types, which were received from this server on the accounting port.

Packets Dropped The number of RADIUS packets received from this server on the accounting port and dropped for some other reason.

8.2.18 *show authentication*

This command displays the ordered authentication methods for all authentication login lists.

Format show authentication

Mode Privileged EXEC Authentication

Login List This displays the authentication login listname.

Method 1 This displays the first method in the specified authentication login list, if any.

Method 2 This displays the second method in the specified authentication login list, if any.

Method 3 This displays the third method in the specified authentication login list, if any.

8.2.19 *show authentication users*

This command displays information about the users assigned to the specified authentication login list. If the login is assigned to non-configured users, the user "default" will appear in the user column.

Format show authentication users <listname>

Mode Privileged EXEC

User This field displays the user assigned to the specified authentication login list.

Component This field displays the component (User or 802.1x) for which the authentication login list is assigned.

8.2.20 show dot1x

This command is used to show a summary of the global dot1x configuration, summary information of the dot1x configuration for a specified port or all ports, the detailed dot1x configuration for a specified port and the dot1x statistics for a specified port - depending on the tokens used.

Format show dot1x [{summary {<unit/slot/port> | all} | {detail <unit/slot/port>} | {statistics <unit/slot/port>}]

Mode Privileged EXEC

If none of the optional parameters are used, the global dot1x configuration summary is displayed.

Administrative mode Indicates whether authentication control on the switch is enabled or disabled.

If the optional parameter 'summary {<unit/slot/port> | all}' is used, the dot1x configuration for the specified port or all ports are displayed.

Port The interface whose configuration is displayed.

Control Mode The configured control mode for this port. Possible values are force-unauthorized | force-authorized | auto

Operating Control Mode The control mode under which this port is operating. Possible values are authorized | unauthorized

Reauthentication Enabled Indicates whether re-authentication is enabled on this port

Key Transmission Enabled Indicates if the key is transmitted to the supplicant for the specified port

If the optional parameter 'detail <unit/slot/port>' is used, the detailed dot1x configuration for the specified port are displayed.

Port The interface whose configuration is displayed

Protocol Version The protocol version associated with this port. The only possible value is 1, corresponding to the first version of the dot1x specification.

PAE Capabilities The port access entity (PAE) functionality of this port. Possible values are Authenticator or Supplicant.

Authenticator PAE State Current state of the authenticator PAE state machine. Possible values are Initialize, Disconnected, Connecting, Authenticating, Authenticated, Aborting, Held, ForceAuthorized, and ForceUnauthorized.

Backend Authentication State Current state of the backend authentication state machine. Possible values are Request, Response, Success, Fail, Timeout, Idle, and Initialize.

Quiet Period The timer used by the authenticator state machine on this port to define periods of time in which it will not attempt to acquire a supplicant. The value is expressed in seconds and will be in the range 0 and 65535.

Transmit Period The timer used by the authenticator state machine on the specified port to determine when to send an EAPOL EAP Request/Identity frame to the supplicant. The value is expressed in seconds and will be in the range of 1 and 65535.

Supplicant Timeout The timer used by the authenticator state machine on this port to timeout the supplicant. The value is expressed in seconds and will be in the range of 1 and 65535.

Server Timeout The timer used by the authenticator on this port to timeout the authentication server. The value is expressed in seconds and will be in the range of 1 and 65535.

Maximum Requests The maximum number of times the authenticator state machine on this port will

retransmit an EAPOL EAP Request/Identity before timing out the supplicant. The value will be in the range of 1 and 10.

Reauthentication Period The timer used by the authenticator state machine on this port to determine when reauthentication of the supplicant takes place. The value is expressed in seconds and will be in the range of 1 and 65535.

Reauthentication Enabled Indicates if reauthentication is enabled on this port. Possible values are "True" or "False".

Key Transmission Enabled Indicates if the key is transmitted to the supplicant for the specified port. Possible values are True or False.

Control Direction Indicates the control direction for the specified port or ports. Possible values are both or in.

If the optional parameter 'statistics <unit/slot/port>' is used, the dot1x statistics for the specified port are displayed.

Port The interface whose statistics are displayed.

EAPOL Frames Received The number of valid EAPOL frames of any type that have been received by this authenticator.

EAPOL Frames Transmitted The number of EAPOL frames of any type that have been transmitted by this authenticator.

EAPOL Start Frames Received The number of EAPOL start frames that have been received by this authenticator.

EAPOL Logoff Frames Received The number of EAPOL logoff frames that have been received by this authenticator.

Last EAPOL Frame Version The protocol version number carried in the most recently received EAPOL frame.

Last EAPOL Frame Source The source MAC address carried in the most recently received EAPOL frame.

EAP Response/Id Frames Received The number of EAP response/identity frames that have been received by this authenticator.

EAP Response Frames Received The number of valid EAP response frames (other than resp/id frames) that have been received by this authenticator.

EAP Request/Id Frames Transmitted The number of EAP request/identity frames that have been transmitted by this authenticator.

EAP Request Frames Transmitted The number of EAP request frames (other than request/identity frames) that have been transmitted by this authenticator.

Invalid EAPOL Frames Received The number of EAPOL frames that have been received by this authenticator in which the frame type is not recognized.

EAP Length Error Frames Received The number of EAPOL frames that have been received by this authenticator in which the frame type is not recognized.

8.2.21 show dot1x users

This command displays 802.1x port security user information for locally configured users.

Format show dot1x users <unit/slot/port>
Mode Privileged EXEC
User Users configured locally to have access to the specified port.

8.2.22 show users authentication

This command displays all user and all authentication login information. It also displays the authentication login list assigned to the default user.

Format show users authentication Mode Privileged EXEC
User This field lists every user that has an authentication login list assigned.

System Login This field displays the authentication login list assigned to the user for system login.

802.1x Port Security This field displays the authentication login list assigned to the user for 802.1x port security.

8.2.23 users defaultlogin

This command assigns the authentication login list to use for non-configured users when attempting to log in to the system. This setting is overridden by the authentication login list assigned to a specific user if the user is configured locally. If this value is not configured, users will be authenticated using local authentication only.

Format users defaultlogin <listname>
Mode Global Config

8.2.24 users login

This command assigns the specified authentication login list to the specified user for system login. The <user> must be a configured <user> and the <listname> must be a configured login list.

If the user is assigned a login list that requires remote authentication, all access to the interface from all CLI, web, and telnet sessions will be blocked until the authentication is complete.

Note that the login list associated with the 'admin' user can not be changed to prevent accidental lockout from the switch.

Format users login <user> <listname>
Mode Global Config

8.3 Remote Authentication Dial In User Service (RADIUS) Commands

This section provides a detailed explanation of the RADIUS commands. The commands are divided into the following groups:

- Configuration commands are used to configure features and options of the switch. For every configuration command there is a show command that will display the configuration setting.
- Show commands are used to display switch settings, statistics and other information.

8.3.1 *radius accounting mode*

This command is used to enable the RADIUS accounting function.

Default disabled

Format radius accounting modeMode Global Config

8.3.1.1 *no radius accounting mode*

This command is used to set the RADIUS accounting function to the default value - i.e. the RADIUS accounting function is disabled.

Format no radius accounting mode

Mode Global Config

8.3.2 *radius server host*

This command is used to configure the RADIUS authentication and accounting server.

If the 'auth' token is used, the command configures the IP address to use to connect to a RADIUS authentication server. Up to 3 servers can be configured per RADIUS client. If the maximum number of configured servers is reached, the command will fail until one of the servers is removed by executing the no form of the command. If the optional <port> parameter is used, the command will configure the UDP port number to use to connect to the configured RADIUS server. In order to configure the UDP port number, the IP address must match that of a previously configured RADIUS authentication server. The port number must lie between 1 - 65535, with 1812 being the default value.

If the 'acct' token is used, the command configures the IP address to use for the RADIUS accounting server. Only a single accounting server can be configured. If an accounting server is currently configured, it must be removed from the configuration using the no form of the command before this command succeeds. If the optional <port> parameter is used, the command will configure the UDP port to use to connect to the RADIUS accounting server. The IP address specified must match that of a previously configured accounting server. If a port is already configured for the accounting server then the new port will replace the previously configured value. The port must be a value in the range 1 - 65535, with 1813 being the default value.

Format radius server host {auth | acct} <ipaddr> [<port>]

Mode Global Config

8.3.2.1 *no radius server host*

This command is used to remove the configured RADIUS authentication server or the RADIUS accounting server. If the 'auth' token is used, the previously configured RADIUS authentication server is removed from the configuration. Similarly, if the 'acct' token is used, the previously configured RADIUS accounting server is removed from the configuration. The <ipaddr> parameter must match the IP address of the previously configured RADIUS authentication / accounting server.

Format no radius server host {auth | acct} <ipaddress>

Mode Global Config

8.3.3 radius server key

This command is used to configure the shared secret between the RADIUS client and the RADIUS accounting / authentication server. Depending on whether the 'auth' or 'acct' token is used, the shared secret is configured for the RADIUS authentication or RADIUS accounting server. The IP address provided must match a previously configured server. When this command is executed, the secret is prompted.

Note: The secret must be an alphanumeric value not exceeding 16 characters.

Format radius server key {auth | acct} <ipaddr>

Mode Global Config

8.3.4 radius server msgauth

This command enables the message authenticator attribute for a specified server.

Default radius server msgauth <ipaddr>

Mode Global Config

8.3.5 radius server primary

This command is used to configure the primary RADIUS authentication server for this RADIUS client. The primary server is the one that is used by default for handling RADIUS requests. The remaining configured servers are only used if the primary server cannot be reached. A maximum of three servers can be configured on each client. Only one of these servers can be configured as the primary. If a primary server is already configured prior to this command being executed, the server specified by the IP address specified used in this command will become the new primary server. The IP address must match that of a previously configured RADIUS authentication server.

Format radius server primary <ipaddr>

Mode Global Config

8.3.6 radius server retransmit

This command sets the maximum number of times a request packet is re-transmitted when no response is received from the RADIUS server. The retries value is an integer in the range of 1 to 15.

Default 4

Format radius server retransmit <retries>

Mode Global Config

8.3.6.1 no radius server retransmit

This command sets the maximum number of times a request packet is re-transmitted, to the default value.

Format no radius server retransmit

Mode Global Config

8.3.7 radius server timeout

This command sets the timeout value (in seconds) after which a request must be retransmitted to the RADIUS server if no response is received. The timeout value is an integer in the range of 1 to 30.

Default 5

Format radius server timeout <seconds>

Mode Global Config

8.3.7.1 no radius server timeout

This command sets the timeout value to the default value.

Format no radius server timeout

Mode Global Config

8.3.8 tacacs-server host

This command specifies a TACACS+ host. the WFQ minimum bandwidth for an interface.

Format tacacs-server host <ip-address> [key <key-string>] [port <port-number>] [priority <priority>] [timeout <timeout>] [single-connection]

Mode Global Config

ip-address IP address of the host.

key-string (Optional) Character string specifying authentication and encryption key. Specifying this key overrides the key set by the global command tacacs-server key for this server only.

port-number (Optional) Specifies a TACACS+ server port number. This option overrides the default, which is port 49. Valid port numbers range from 1 through 65535.

priority (Optional) Server priority. The default value is 0.

timeout (Optional) Specifies a timeout value. This value overrides the global timeout value set with the tacacs-server timeout command for this server only. It is an integer value, in seconds, of the timeout interval. The value is from 1 through 30.

Single-connection (optional) Maintains a single open connection between the router and the TACACS+ server.

8.3.8.1 no tacacs-server host

This command delete the specified address of the TACACS+ host.

Format no tacacs-server host <host-ip-address>

Mode Global Config

8.3.9 tacacs-server key

This command sets the authentication encryption key used for all TACACS+ communications between the access server and the TACACS+ daemon.

Format tacacs-server key <key-string>
Mode Global Config
key-string The authentication and encryption key

8.3.9.1 no tacacs-server key

This command deletes the authentication encryption key used for all TACACS+ communications.

Format no tacacs-server key
Mode Global Config

8.3.10 tacacs-server timeout

This command sets the interval for which the server waits for a server host to reply.

Format tacacs-server timeout <seconds>
Mode Global Config

seconds Timeout interval in seconds. The value is from 1 through 30. The default is 5.

8.3.10.1 no tacacs-server timeout

This command restores the default value.

Format no tacacs-server timeout
Mode Global Config

8.3.11 show radius

This command is used to display the various RADIUS configuration items for the switch as well as the configured RADIUS servers. If the optional token 'servers' is not included, the following RADIUS configuration items will be displayed.

Format show radius [*servers*]

Mode Privileged EXEC

Primary Server IP Address Indicates the configured server currently in use for authentication

Number of configured servers The configured IP address of the authentication server

Max number of retransmits The configured value of the maximum number of times a request packet is retransmitted

Timeout Duration The configured timeout value, in seconds, for request re-transmissions

Accounting Mode Yes or No

If the optional token 'servers' is included, the following information regarding the configured RADIUS servers is displayed.

IP Address IP Address of the configured RADIUS server
Port The port in use by this server
Type Primary or secondary

Secret Configured Yes / No

Message Authenticator Enables or disables the message authenticator attribute for the selected server

8.3.12 show radius statistics

This command is used to display the statistics for RADIUS or configured server. To show the configured RADIUS server statistic, the IP Address specified must match that of a previously configured RADIUS server. On execution, the following fields are displayed.

Format show radius statistics [*ipaddr*]

Mode Privileged EXEC

If ip address is not specified then only Invalid Server Address field is displayed. Otherwise other listed fields are displayed.

Invalid Server Addresses The number of RADIUS Access-Response packets received from unknown addresses.

Server IP Address IP Address of the Server.

Round Trip Time The time interval, in hundredths of a second, between the most recent Access-Reply | Access-Challenge and the Access-Request that matched it from the RADIUS authentication server.

Access Requests The number of RADIUS Access-Request packets sent to this server. This number does not include retransmissions.

Access Retransmission The number of RADIUS Access-Request packets retransmitted to this RADIUS authentication server.

Access Accepts The number of RADIUS Access-Accept packets, including both valid and invalid packets, which were received from this server.

Access Rejects The number of RADIUS Access-Reject packets, including both valid and invalid packets, which were received from this server.

Access Challenges The number of RADIUS Access-Challenge packets, including both valid and invalid packets, which were received from this server.

Malformed Access Responses The number of malformed RADIUS Access-Response packets received from this server. Malformed packets include packets with an invalid length. Bad authenticators or signature attributes or unknown types are not included as malformed access responses.

Bad Authenticators The number of RADIUS Access-Response packets containing invalid authenticators or signature attributes received from this server.

Pending Requests The number of RADIUS Access-Request packets destined for this server that have not yet timed out or received a response.

Timeouts The number of authentication timeouts to this server.

Unknown Types The number of RADIUS packets of unknown types, which were received from this server on the authentication port.

Packets Dropped The number of RADIUS packets received from this server on the authentication port and dropped for some other reason.

8.3.13 *show tacacs-server*

This command displays the configuration and status for a specified TACACS+ server or all TACACS+ servers.

Format show tacacs-server [<ip-address>]

Mode Privileged Exec

ip-address This field displays IP address of the TACACS+ server.

Status This field displays the status of TACACS+ server.

Port This field displays the port number of TACACS+ server.

Single connection This field displays the maintenance of a single open connection between the router and the TACACS+ server.

Timeout This field displays the value of timeout setting.

Priority This field displays the value of priority setting.

8.4 Secure Shell (SSH) Commands

This section provides a detailed explanation of the SSH commands. The commands are divided into the following groups:

- Configuration commands are used to configure features and options of the switch. For every configuration command there is a show command that will display the configuration setting.
- Show commands are used to display switch settings, statistics and other information

Note: A maximum of 5 SSH sessions is allowed.

8.4.1 *ip ssh*

This command is used to enable SSH.

Default	disabled
Format	ip ssh
Mode	Privileged EXEC

8.4.1.1 *no ip ssh*

This command is used to disable SSH.

Format	no ip ssh
Mode	Privileged EXEC

8.4.2 *ip ssh protocol*

This command is used to set or remove protocol levels (or versions) for SSH. Either SSH1 (1), SSH2 (2), or both SSH 1 and SSH 2 (1 and 2) can be set.

Default	1 and 2
Format	ip ssh protocol [1] [2]
Mode	Privileged EXEC

8.4.3 *sshcon maxsessions*

This command specifies the maximum number of SSH connection sessions that can be established. A value of 0 indicates that no ssh connection can be established. The range is 0 to 5.

Default	5
Format	telnetcon maxsessions <0-5>
Mode	Privileged EXEC

8.4.3.1 *no sshcon maxsessions*

This command sets the maximum number of allowed SSH connection sessions to the default value.

Format	no telnetcon maxsessions
Mode	Privileged EXEC

8.4.4 *sshcon timeout*

This command sets the SSH connection session timeout value, in minutes. A session is active as long as

the session has been idle for the value set. The time is a decimal value from 1 to 160. Changing the timeout value for active sessions does not become effective until the session is reaccessed.

Also, any keystroke activates the new timeout duration.

Default	5
Format	telnetcon timeout <1-160>
Mode	Privileged EXEC

8.4.4.1 *no sshcon timeout*

This command sets the SSH connection session timeout value, in minutes, to the default.

Changing the timeout value for active sessions does not become effective until the session is reaccessed. Also, any keystroke activates the new timeout duration.

Format	no telnetcon timeout
Mode	Privileged EXEC

8.4.5 *show ip ssh*

This command displays the ssh settings.

Format	show ip ssh
Mode	Privileged EXEC
Administrative Mode	This field indicates whether the administrative mode of SSH is enabled or disabled.
Protocol Level	The protocol level may have the values of version 1, version 2 or both versions 1 and version 2.
Connections	This field specifies the current SSH connections.

8.5 Hypertext Transfer Protocol (HTTP) Commands

This section provides a detailed explanation of the HTTP commands. The commands are divided into the following groups:

- Configuration commands are used to configure features and options of the switch. For every configuration command there is a show command that will display the configuration setting.
- Show commands are used to display switch settings, statistics and other information.

8.5.1 *ip http secure-port*

This command is used to set the sslt port where port can be 1-65535 and the default is port 443.

Default	443
Format	ip http secure-port <portid>
Mode	Privileged EXEC

8.5.1.1 *no ip http secure-port*

This command is used to reset the sslt port to the default value.

Format	no ip http secure-port
Mode	Privileged EXEC

8.5.2 *ip http secure-protocol*

This command is used to set protocol levels (versions). The protocol level can be set to TLS1, SSL3 or to both TLS1 and SSL3.

Default	SSL3 and TLS1
Format	ip http secure-protocol [SSL3] [TLS1]
Mode	Privileged EXEC

8.5.3 *ip http secure-server*

This command is used to enable the secure socket layer for secure HTTP.

Default	disabled
Format	ip http secure-server
Mode	Privileged EXEC

8.5.3.1 *no ip http secure-server*

This command is used to disable the secure socket layer for secure HTTP.

Format	ip http secure-server
Mode	Privileged EXEC

8.5.4 *ip http server*

This command enables access to the switch through the Web interface. When access is enabled, the user can login to the switch from the Web interface. When access is disabled, the user cannot login to the switch's Web server.

Disabling the Web interface takes effect immediately. All interfaces are effected.

Default	enabled
Format	ip http server
Mode	Privileged EXEC

8.5.4.1 *no ip http server*

This command disables access to the switch through the Web interface. When access is disabled, the user cannot login to the switch's Web server.

Format	no ip http server
Mode	Privileged EXEC

8.5.5 *show ip http*

This command displays the http settings for the switch.

Format	show ip http
Mode	Privileged EXEC

Secure-Server Administrative Mode This field indicates whether the administrative mode of secure HTTP is enabled or disabled.

Secure Protocol Level The protocol level may have the values of SSL3, TSL1, or both SSL3 and TSL1.

Secure Port This field specifies the port configured for SSLT.

HTTP Mode This field indicates whether the HTTP mode is enabled or disabled.

9.0 Quality of Service (QoS) Commands

This chapter provides a detailed explanation of the Quality of Service (QoS) commands. The following QoS commands are available in the switch's QoS module.

The commands are divided into these different groups:

- Show commands are used to display device settings, statistics and other information.
- Configuration Commands are used to configure features and options of the switch. For every configuration command there is a show command that will display the configuration setting.

9.1 MAC Access Control List (ACL) Commands

MAC Access Control Lists (ACLs) ensure that only authorized users have access to specific resources while blocking off any unwarranted attempts to reach network resources.

Note:

- MAC ACL configuration for IP packet fragments is not supported.
- The maximum number of ACLs of any type that can be created is 100.
- Only Ethernet II frame types are supported.
- The maximum number of rules per MAC ACL translates into the number of hardware classifier entries used when an ACL is attached to an interface. Increasing these values in the switch increases the RAM and NVSTORE usage.
- ACLs are configured separately for Layer 2 and Layer 3/Layer 4. Some types of hardware do not allow both types of ACLs to be applied to the same interface.
- Wildcard masking for ACLs operates differently from a subnet mask. A wildcard mask is in essence the inverse of a subnet mask. With a subnet mask, the mask has ones (1's) in the bit positions that are used for the network address, and has zeros (0's) for the bit positions that are not used. In contrast, a wildcard mask has (0's) in a bit position that must be checked. A '1' in a bit position of the ACL mask indicates the corresponding bit can be ignored.

9.1.1 *mac access-list extended*

This command creates a MAC Access Control List (ACL) identified by <name>, consisting of classification fields defined for the Layer 2 header of an Ethernet frame. The <name> parameter is a case-sensitive alphanumeric string from 1 to 31 characters uniquely identifying the MAC access list.

If a MAC ACL by this name already exists, this command enters Mac-Access-List config mode to allow updating the existing MAC ACL.

Note: The CLI mode is changed to Mac-Access-List Config when this command is successfully executed.

Format mac access-list extended <name>

Mode Global Config

9.1.1.1 *no mac access-list extended*

This command deletes a MAC ACL identified by <name> from the system.

Format no mac access-list extended <name>

Mode Global Config

9.1.2 mac access-list extended rename

This command changes the name of a MAC Access Control List (ACL). The <name> parameter is the name of an existing MAC ACL. The <newname> parameter is a case-sensitive alphanumeric string from 1 to 31 characters uniquely identifying the MAC access list.

This command fails if a MAC ACL by the name <newname> already exists.

Format mac access-list extended rename <name> <newname>

Mode Global Config

9.1.3 {deny/permit}

This command creates a new rule for the current MAC access list. Each rule is appended to the list of configured rules for the list.

Note: The 'no' form of this command is not supported, since the rules within a MAC ACL cannot be deleted individually. Rather, the entire MAC ACL must be deleted and re-specified.

Note: An implicit 'deny all' MAC rule always terminates the access list.

A rule may either deny or permit traffic according to the specified classification fields. At a minimum, the source and destination MAC value and mask pairs must be specified, each of which may be substituted using the keyword any to indicate a match on any value in that field. The bpdud keyword may be specified for the destination MAC value/mask pair indicating a well-known BPDU MAC value of 01-80-c2-xx-xx-xx (hex), where 'xx' indicates a don't care. The remaining command parameters are all optional, but the most frequently used parameters appear in the same relative order as shown in the command format.

The Ethertype may be specified as either a keyword or a four-digit hexadecimal value from 0x06000xFFFF. The currently supported <ethertypekey> values are: appletalk, arp, ibmsna, ipv4, ipv6, ipx, mplsmcast, mplsucast, netbios, novell, pppoe, rarp. Each of these translates into its equivalent Ethertype value(s).

Table 13. Ethertype Keyword and 4-digit Hexadecimal Value

Ethertype Keyword	Corresponding Value
appletalk	0x809B
arp	0x0806
ibmsna	0x80D5
ipv4	0x0800
ipv6	0x86DD
ipx	0x8037
mplsmcast	0x8848

mplsucast	0x8847
netbios	0x8191
novell	0x8137, 0x8138
pppoe	0x8863, 0x8864
rarp	0x8035

The vlan and cos parameters refer to the VLAN identifier and 802.1p user priority fields, respectively, of the VLAN tag. For packets containing a double VLAN tag, this is the first (or outer) tag. In contrast, the secondary-vlan and secondary-cos parameters refer to equivalent fields contained in the inner tag of a double VLAN-tagged packet (These fields are not present in a packet with a single tag.).

The assign-queue parameter allows specification of a particular hardware queue for handling traffic that matches this rule. The allowed <queue-id> value is 0-(n-1), where n is the number of user configurable queues available for the hardware platform. The redirect parameter allows the traffic matching this rule to be forwarded to the specified <unit/slot/port>. The assign-queue and redirect parameters are only valid for a 'permit' rule.

Format {deny|permit} {{<srcmac> <srcmacmask> | any} {{<dstmac> <dstmac-mask> | any | bpdu} [<ethertypekey> | <0x0600-0xFFFF>] [vlan{{eq <0-4095> | {range <0-4095> <0-4095>}}}] [cos <0-7>] [sec-ondary-vlan {{eq <0-4095> | {range <0-4095> <0-4095>}}}] [sec-ondary-cos <0-7>] [assign-queue <queue-id>] [redirect <unit/slot/port>]

Note: The special command form {deny|permit} any any is used to match all Ethernet layer 2 packets, and is the equivalent of the IP access list "match every" rule.

Mode Mac-Access-List Config

9.1.4 mac access-group

This command attaches a specific MAC Access Control List (ACL) identified by <name> to an interface in a given direction. The <name> parameter must be the name of an existing MAC ACL.

An optional sequence number may be specified to indicate the order of this mac access list relative to other mac access lists already assigned to this interface and direction. A lower number indicates higher precedence order. If a sequence number is already in use for this interface and direction, the specified mac access list replaces the currently attached mac access list using that sequence number. If the sequence number is not specified for this command, a sequence number that is one greater than the highest sequence number currently in use for this interface and direction is used.

This command specified in 'Interface Config' mode only affects a single interface, whereas the 'Global Config' mode setting is applied to all interfaces. The 'Interface Config' mode command is only available on platforms that support independent per-port class of service queue configuration.

Format mac access-group <name> [in|out] [sequence <1-4294967295>]

Modes Global ConfigInterface Config

9.1.4.1 no mac access-group

This command removes a MAC ACL identified by <name> from the interface in a given direction.

Format no mac access-list <name> [in|out]

Modes Global Config Interface Config

9.1.5 show mac access-lists

This command displays a MAC access list and all of the rules that are defined for the MAC ACL. The [name] parameter is used to identify a specific MAC ACL to display.

Format show mac access-lists [name]

Mode Privileged EXEC

Rule Number The ordered rule number identifier defined within the MAC ACL.

Action Displays the action associated with each rule. The possible values are Permit or Deny.

Source MAC Address Displays the source MAC address for this rule.

Source MAC Mask Displays the source MAC mask for this rule.

Destination MAC Address Displays the destination MAC address for this rule.

Destination MAC Mask Displays the destination MAC mask for this rule.

Ethertype Displays the Ethertype keyword or custom value for this rule.

VLAN ID Displays the VLAN identifier value or range for this rule.

COS Displays the COS (802.1p) value for this rule.

Secondary VLAN ID Displays the Secondary VLAN identifier value or range for this rule. This field is contained in the inner tag of a double VLAN-tagged packet.

Secondary COS Displays the Secondary COS (802.1p) value for this rule. This field is contained in the inner tag of a double VLAN-tagged packet.

Assign Queue Displays the queue identifier to which packets matching this rule are assigned.

Redirect Interface Displays the unit/slot/port to which packets matching this rule are forwarded.

9.1.6 show mac acl-counters

This command display MAC Access List Counters information

Format show mac acl-counters <unit/slot/port> <in | out>

Modes Privileged EXEC User EXEC

9.2 IP Access Control List (ACL) Commands

IP Access Control Lists (ACLs) ensure that only authorized users have access to specific resources while blocking off any unwarranted attempts to reach network resources.

Note:

- IP ACL configuration for IP packet fragments is not supported.
- The maximum number of ACLs of any type that can be created is 100.
- The maximum number of rules per IP ACL translates into the number of hardware classifier entries used when an IP ACL is attached to an interface. Increasing these values in the switch increases the RAM and NVSTORE usage.
- ACLs are configured separately for Layer 2 and Layer 3. Some types of hardware do not allow both types of ACLs to be applied to the same interface.
- Wildcard masking for ACLs operates differently from a subnet mask. A wildcard mask is in essence the inverse of a subnet mask. With a subnet mask, the mask has ones (1's) in the bit positions that are used for the network address, and has zeros (0's) for the bit positions that are not used. In contrast, a wildcard mask has (0's) in a bit position that must be checked. A '1' in a bit position of the ACL mask indicates the corresponding bit can be ignored.

9.2.1 *access-list*

This command creates an IP Access Control List (ACL) that is identified by the parameter *<accesslistnumber>*.

The IP ACL number (*<accesslistnumber>*) is an integer from 1 to 199. The *<accesslistnumber>* range 1 to 99 is for an IP standard ACL and the *<accesslistnumber>* range 100 to 199 is for an IP extended ACL.

The IP ACL rule is specified with either a *permit* or *deny* action.

The protocol to filter for an IP ACL rule is specified by giving the protocol to be used like *icmp, igmp, ip, tcp, udp*.

The command specifies a source ipaddress and source mask for match condition of the IP ACL rule specified by the *srcip* and *srcmask* parameters.

The source layer 4 port match condition for the IP ACL rule are specified by the *port value* parameter. The *<startport>* and *<endport>* parameters identify the first and last ports that are part of the port range. They have values from 0 to 65535. The ending port must have a value equal or greater than the starting port. The starting port, ending port, and all ports in between will be part of the destination port range.

The *<portvalue>* parameter uses a single keyword notation and currently has the values of *domain, echo, ftp, ftpdata, http, smtp, snmp, telnet, tftp, and www*. Each of these values translates into its equivalent port number, which is used as both the start and end of a port range.

The command specifies a destination ipaddress and destination mask for match condition of the IP ACL rule specified by the *dstip* and *dstmask* parameters.

The command specifies the TOS for an IP ACL rule depending on a match of precedence or DSCP values using the parameters *dscp, precedence, tos, tosmask*.

The command specifies the assign-queue which is the queue identifier to which packets matching this rule are assigned.

The command specifies the redirect interface which is the unit/slot/port to which packets matching

this rule are forwarded.

Default none

(IP Standard ACL)

Format access-list <1-99> {deny | permit} <srcip> <srcmask> Mode Global Config

(IP Extended ACL)

Format access-list <100-199> {deny | permit} {every | {{icmp | igmp | ip | tcp | udp | <number>} <srcip> <srcmask>[{eq {<portkey> | <portvalue>} | range <startport> <endport>}] <dstip> <dstmask> [{eq {<portkey> | <portvalue>} | range <startport> <endport>}][precedence <precedence> | tos <tos> <tosmask> | dscp <dscp>][assign-queue <queue-id>] [redirect <unit/slot/port>]}}

Mode Global Config

9.2.1.1 no access-list

This command deletes an IP ACL that is identified by the parameter <accesslistnumber> from the system.

Format no access-list <accesslistnumber>

Mode Global Config

9.2.2 ip access-group

This command attaches a specified IP access-control list to an interface.

An optional sequence number may be specified to indicate the order of this IP access list relative to other IP access lists already assigned to this interface and direction. A lower number indicates higher precedence order. If a sequence number is already in use for this interface and direction, the specified access list replaces the currently attached IP access list using that sequence number. If the sequence number is not specified for this command, a sequence number that is one greater than the highest sequence number currently in use for this interface and direction is used.

Default none

Format ip access-group <accesslistnumber> <in | out> [sequence <1-4294967295>]

Mode Interface Config

9.2.2.1 no ip access-group

This command removes a specified IP access-control list from an interface.

Default none

Format no ip access-group <accesslistnumber> <in | out>

Mode Interface Config

9.2.3 show ip access-lists

This command displays an IP Access Control List (ACL) and all of the rules that are defined for the IP ACL. The *<accesslistnumber>* is the number used to identify the IP ACL.

Format show ip access-lists *<accesslistnumber>*

Modes Privileged EXEC User EXEC

Rule Number This displays the number identifier for each rule that is defined for the IP ACL.

Action This displays the action associated with each rule. The possible values are Permit or Deny.

Protocol This displays the protocol to filter for this rule.

Source IP Address This displays the source IP address for this rule.

Source IP Mask This field displays the source IP Mask for this rule.

Source Ports This field displays the source port range for this rule.

Destination IP Address This displays the destination IP address for this rule.

Destination IP Mask This field displays the destination IP Mask for this rule.

Destination Ports This field displays the destination port range for this rule.

Service Type Field Match This field indicates whether an IP DSCP, IP Precedence, or IP TOS match condition is specified for this rule.

Service Type Field Value This field indicates the value specified for the Service Type Field Match (IP DSCP, IP Precedence, or IP TOS).

9.2.4 show access-list interface

This command displays show access-list information.

Format show access-list interface *<unit/slot/port>* *<in | out>*

Modes Privileged EXEC User EXEC

9.2.5 show ip acl-counters (only for Layer 2 Series)

This command display IP Access List Counters information

Format show ip acl-counters *<1-199>* *<interface>*

Modes Privileged EXEC User EXEC

9.3 Differentiated Services (DiffServ) Commands

This chapter contains the CLI commands used for the QOS Differentiated Services (DiffServ) package.

The user configures DiffServ in several stages by specifying:

1. Class

- creating and deleting classes
- defining match criteria for a class.

Note: The only way to remove an individual match criterion from an existing class definition is to delete the class and re-create it.

2. Policy

- creating and deleting policies
- associating classes with a policy
- defining policy statements for a policy/class combination

3. Service

- adding and removing a policy to/from an inbound interface

Packets are filtered and processed based on defined criteria. The filtering criteria is defined by a class. The processing is defined by a policy's attributes. Policy attributes may be defined on a per-class instance basis, and it is these attributes that are applied when a match occurs.

Packet processing begins by testing the match criteria for a packet. A policy is applied to a packet when a class match within that policy is found.

Note that the type of class - all, any, or acl - has a bearing on the validity of match criteria specified when defining the class. A class type of 'any' processes its match rules in an ordered sequence; additional rules specified for such a class simply extend this list. A class type of 'acl' obtains its rule list by interpreting each ACL rule definition at the time the Diffserv class is created. Differences arise when specifying match criteria for a class type 'all', since only one value for each non-excluded match field is allowed within a class definition. If a field is already specified for a class, all subsequent attempts to specify the same field fail, including the cases where a field can be specified multiple ways through alternative formats. The exception to this is when the 'exclude' option is specified, in which case this restriction does not apply to the excluded fields.

The following class restrictions are imposed by the switch's DiffServ design:

1. □ nested class support limited to:
 - 'any' within 'any'
 - 'all' within 'all'
 - no nested 'not' conditions
 - no nested 'acl' class types
 - each class contains at most one referenced class □
2. hierarchical service policies not supported in a class definition □
3. access list matched by reference only, and must be sole criterion in a class
 - ACL rules copied as class match criteria at time of class creation, with class type 'any'
 - implicit ACL 'deny all' rule also copied
 - no nesting of class type 'acl'

Regarding nested classes, referred to here as class references, a given class definition can contain

at most one reference to another class, which can be combined with other match criteria. The referenced class is truly a reference and not a copy, since additions to a referenced class affect all classes that reference it. Changes to any class definition. currently referenced by any other class must result in valid class definitions for all derived classes otherwise the change is rejected. A class reference may be removed from a class definition.

The user can display summary and detailed information for classes, policies and services. All configuration information is accessible via the CLI, Web, and SNMP user interfaces.

9.3.1 *diffserv*

This command sets the DiffServ operational mode to active. While disabled, the DiffServ configuration is retained and can be changed, but it is not activated. When enabled, Diffserv services are activated.

Format diffserv
Mode Global Config

9.3.1.1 *no diffserv*

This command sets the DiffServ operational mode to inactive. While disabled, the DiffServ configuration is retained and can be changed, but it is not activated. When enabled, Diffserv services are activated.

Format no diffserv
Mode Global Config

9.4 Class Commands

The 'class' command set is used in DiffServ to define:

Traffic Classification Specify Behavior Aggregate (BA), based on DSCP, and Multi-Field (MF) classes of traffic (name, match criteria)

This set of commands consists of class creation/deletion and matching, with the class match commands specifying Layer 3, Layer 2, and general match criteria. The class match criteria are also known as class rules, with a class definition consisting of one or more rules to identify the traffic belonging to the class.

Note: Once a class match criterion is created for a class, it cannot be changed or deleted. To change or delete a class match criterion, the entire class must be deleted and re-created.

The CLI command root is **class-map**.

9.4.1 class-map

This command defines a DiffServ class of type match-all, match-any or match-access-group. The **<classname>** parameter is a case sensitive alphanumeric string from 1 to 31 characters uniquely identifying the class.

Note: The class name 'default' is reserved and must not be used here.

When used without any match condition, this command enters the class-map mode. The **<classname>** is the name of an existing DiffServ class.

Note: The class name 'default' is reserved and is not allowed here.

The class type of **match-all** indicates all of the individual match conditions must be true for a packet to be considered a member of the class.

The class type of **match-any** indicates only one of the match criteria must be true for a packet to belong to the class; multiple matching criteria are evaluated in a sequential order, with the highest precedence awarded to the first criterion defined for the class.

The class type of **match-access-group** indicates the individual class match criteria are evaluated based on an access list (ACL). The **<aclid>** parameter is an integer specifying an existing ACL number (refer to the appropriate ACL documentation for the valid ACL number range). The **<mac-acl-name>** parameter is a case-sensitive alphanumeric string from 1 to 31 characters uniquely identifying the MAC access list. (Use the **mac access-list extended** command to create a MAC access list.)

A **match-access-group** class type copies its set of match criteria from the current rule definition of the specified ACL number. All elements of a single ACL Rule are treated by DiffServ as a grouped set, similar to class type all. For any class, at least one class match condition must be specified for the class to be considered valid.

Note: The class match conditions are obtained from the referenced access list **at the time of class creation**. Thus, any subsequent changes to the referenced ACL definition do not affect the DiffServ class. To pick up the latest ACL definition, the DiffServ class must be deleted and re-created.

This command may be used without specifying a class type to enter the Class-Map Config mode for an existing DiffServ class.

Note: The CLI mode is changed to Class-Map Config when this command is successfully executed.

Format class-map match-access-group <class-map-name> <aclid>class-map match-all
<class-map-name>class-map match-any <class-map-name>class-map
match-mac-access-group <class-map-name> <mac-acl name>
Mode Global Config

9.4.1.1 no class-map

This command eliminates an existing DiffServ class. The **<classname>** is the name of an existing DiffServ class (note: the class name 'default' is reserved and is not allowed here). This command may be issued at any time; if the class is currently referenced by one or more policies or by any other class, this deletion attempt shall fail.

Format no class-map <classname>
Mode Global Config

9.4.2 class-map rename

This command changes the name of a DiffServ class. The **<classname>** is the name of an existing DiffServ class. The **<newclassname>** parameter is a case-sensitive alphanumeric string from 1 to 31 characters uniquely identifying the class (Note: the class name 'default' is reserved and must not be used here).

Default none
Format class-map rename <classname> <newclassname>
Mode Global Config

9.4.3 match ethertype

This command adds to the specified class definition a match condition based on the value of the ethertype. The **<ethertype>** value is specified as one of the following keywords: **appletalk, arp, ibmsna, ipv4, ipv6, ipx, mplsicast, mplsucast, netbios, novell, pppoe, rarp** or as a custom ethertype value in the range of 0x0600-0xFFFF.

Format match [not] ethertype {<keyword> | custom <0x0600-0xFFFF>}
Mode Class-Map Config

9.4.4 match any

This command adds to the specified class definition a match condition whereby all packets are considered to belong to the class. The optional **[not]** parameter has the effect of negating this match condition for the class (i.e., none of the packets are considered to belong to the class).

Default none
Format match [not] any
Mode Class-Map Config

9.4.5 match class-map

This command adds to the specified class definition the set of match conditions defined for another class. The `<refclassname>` is the name of an existing DiffServ class whose match conditions are being referenced by the specified class definition.

Note: there is no `[not]` option for this match command.

Default	none
Format	match class-map <code><refclassname></code>
Mode	Class-Map Config

Restrictions The class types of both `<classname>` and `<refclassname>` must be identical (i.e., any vs. any, or all vs. all). A class type of acl is not supported by this command. Cannot specify `<refclassname>` the same as `<classname>` (i.e., self-referencing of class name not allowed).

At most one other class may be referenced by a class.

Any attempt to delete the `<refclassname>` class while still referenced by any `<classname>` shall fail. The combined match criteria of `<classname>` and `<refclassname>` must be an allowed combination based on the class type. Any subsequent changes to the `<ref-classname>` class match criteria must maintain this validity, or the change attempt shall fail.

The total number of class rules formed by the complete reference class chain (includes both predecessor and successor classes) must not exceed a platform-specific maximum.

In some cases, each removal of a reclass rule reduces the maximum number of available rules in the class definition by one.

9.4.5.1 no match class-map

This command removes from the specified class definition the set of match conditions defined for another class. The `<refclassname>` is the name of an existing DiffServ class whose match conditions are being referenced by the specified class definition. Note: there is no `[not]` option for this match command.

Format	no match class-map <code><refclassname></code>
Mode	Class-Map Config

9.4.6 match cos

This command adds to the specified class definition a match condition for the Class of Service value (the only tag in a single tagged packet or the first or outer 802.1Q tag of a double VLAN tagged packet). The value may be from 0 to 7. The optional `[not]` parameter has the effect of negating this match condition for the class (i.e., match all class of service values except for what is specified here).

Default	none
Format	match <code>[not]</code> cos <code><0-7></code>
Mode	Class-Map Config

9.4.7 match destination-address mac

This command adds to the specified class definition a match condition based on the destination MAC address of a packet. The `<macaddr>` parameter is any layer 2 MAC address formatted as six, two-digit hexadecimal numbers separated by colons (e.g., 00:11:22:dd:ee:ff). The `<macmask>` parameter is a layer 2 MAC address bit mask, which need not be contiguous, and is formatted as six, two-digit hexadecimal numbers separated by colons (e.g., ff:07:23:ff:fe:dc). The optional `[not]` parameter has the effect of negating this match condition for the class (i.e., match all destination MAC addresses except for what is specified here).

Default	none
Format	match [not] destination-address mac <macaddr> <macmask>
Mode	Class-Map Config

9.4.8 match dstip

This command adds to the specified class definition a match condition based on the destination IP address of a packet. The `<ipaddr>` parameter specifies an IP address. The `<ipmask>` parameter specifies an IP address bit mask; note that although similar to a standard subnet mask, this bit mask need not be contiguous. The optional `[not]` parameter has the effect of negating this match condition for the class (i.e., match all destination IP addresses except for what is specified here).

Default	none
Format	match [not] dstip <ipaddr> <ipmask>
Mode	Class-Map Config

9.4.9 match dstl4port

This command adds to the specified class definition a match condition based on the destination layer 4 port of a packet using a single keyword or numeric notation or a numeric range notation. To specify the match condition as a single keyword, the value for `<portkey>` is one of the supported port name keywords. The currently supported `<portkey>` values are: **domain**, **echo**, **ftp**, **ftpdata**, **http**, **smtp**, **snmp**, **telnet**, **tftp**, **www**. Each of these translates into its equivalent port number, which is used as both the start and end of a port range.

To specify the match condition using a numeric notation, one layer 4 port number is required. The port number is an integer from 0 to 65535.

To specify the match condition using a numeric range notation, two layer 4 port numbers are required and together they specify a contiguous port range. Each port number is an integer from 0 to 65535, but with the added requirement that the second number be equal to or greater than the first.

The optional `[not]` parameter has the effect of negating this match condition for the class (i.e., match all destination layer 4 port numbers except for the one specified here).

Default	none
Format	match [not] dstl4port {portkey <0-65535>} [0-65535]

Mode Class-Map Config

9.4.10 match ip dscp

This command adds to the specified class definition a match condition based on the value of the IP DiffServ Code Point (DSCP) field in a packet, which is defined as the high-order six bits of the Service Type octet in the IP header (the low-order two bits are not checked). The optional **[not]** parameter has the effect of negating this match condition for the class (i.e., match all IP DSCP values except for what is specified here). The **<dscpval>** value is specified as either an integer from 0 to 63, or symbolically through one of the following keywords: **af11, af12, af13, af21, af22, af23, af31, af32, af33, af41, af42, af43, be, cs0, cs1, cs2, cs3, cs4, cs5, cs6, cs7, ef**.

Note: The ip dscp, ip precedence, and ip tos match conditions are alternative ways to specify a match criterion for the same Service Type field in the IP header, but with a slightly different user notation.

Note: To specify a match on all DSCP values, use the match [not] ip tos <tosbits> <tosmask> command with **<tosbits>** set to 0 and **<tosmask>** set to 03 (hex).

Default none
Format match [not] ip dscp <dscpval>
Mode Class-Map Config

9.4.11 match ip precedence

This command adds to the specified class definition a match condition based on the value of the IP Precedence field in a packet, which is defined as the high-order three bits of the Service Type octet in the IP header (the low-order five bits are not checked). The precedence value is an integer from 0 to 7. The optional **[not]** parameter has the effect of negating this match condition for the class (i.e., match all IP Precedence values except for what is specified here).

Note: The ip dscp, ip precedence, and ip tos match conditions are alternative ways to specify a match criterion for the same Service Type field in the IP header, but with a slightly different user notation.

Note: To specify a match on all Precedence values, use the match [not] ip tos <tosbits> <tosmask> command with **<tosbits>** set to 0 and **<tosmask>** set to 1F (hex).

Default none
Format match [not] ip precedence <0-7>
Mode Class-Map Config

9.4.12 match ip tos

This command adds to the specified class definition a match condition based on the value of the IP TOS field in a packet, which is defined as all eight bits of the Service Type octet in the IP header. The value of **<tosbits>** is a two-digit hexadecimal number from 00 to ff. The value of **<tosmask>** is a two-digit hexadecimal number from 00 to ff. The optional **[not]** parameter has the effect of negating this match condition for the class (i.e., match all IP Precedence values except for what is specified here). The **<tosmask>** denotes the bit positions in **<tosbits>** that are used for comparison against the IP TOS field in a packet. For example, to check for an IP TOS value having bits 7 and 5 set and

bit 1 clear, where bit 7 is most significant, use a **<tosbits>** value of a0 (hex) and a **<tosmask>** of a2 (hex).

Note: The ip dscp, ip precedence, and ip tos match conditions are alternative ways to specify a match criterion for the same Service Type field in the IP header, but with a slightly different user notation.

Note: In essence, this the “free form” version of the IP DSCP/Precedence/TOS match specification in that the user has complete control of specifying which bits of the IP Service Type field are checked.

Default	none
Format	match [not] ip tos <tosbits> <tosmask>
Mode	Class-Map Config

9.4.13 match protocol

This command adds to the specified class definition a match condition based on the value of the IP Protocol field in a packet using a single keyword notation or a numeric value notation.

To specify the match condition using a single keyword notation, the value for **<protocol-name>** is one of the supported protocol name keywords. The currently supported values are: **icmp**, **igmp**, **ip**, **tcp**, **udp**. Note that a value of **ip** is interpreted to match all protocol number values.

To specify the match condition using a numeric value notation, the protocol number is a standard value assigned by IANA and is interpreted as an integer from 0 to 255. Note: This command does not validate the protocol number value against the current list defined by IANA.

The optional **[not]** parameter has the effect of negating this match condition for the class (i.e., match all IP Protocol numbers except for the one specified here).

Default	none
Format	match [not] protocol {protocol-name <0-255>}
Mode	Class-Map Config

9.4.14 match source-address mac

This command adds to the specified class definition a match condition based on the source MAC address of a packet. The **<address>** parameter is any layer 2 MAC address formatted as six, two-digit hexadecimal numbers separated by colons (e.g., 00:11:22:dd:ee:ff). The **<macmask>** parameter is a layer 2 MAC address bit mask, which need not be contiguous, and is formatted as six, two-digit hexadecimal numbers separated by colons (e.g., ff:07:23:ff:fe:dc). The optional **[not]** parameter has the effect of negating this match condition for the class (i.e., match all source MAC addresses except for what is specified here).

Default	none
Format	match [not] source-address mac <address> <macmask>
Mode	Class-Map Config

9.4.15 match srcip

This command adds to the specified class definition a match condition based on the source IP address of a packet. The <ipaddr> parameter specifies an IP address. The <ipmask> parameter specifies an IP address bit mask; note that although it resembles a standard subnet mask, this bit mask need not be contiguous. The optional **[not]** parameter has the effect of negating this match condition for the class (i.e., match all source IP addresses except for what is specified here).

Default	none
Format	match [not] srcip <ipaddr> <ipmask>
Mode	Class-Map Config

9.4.16 match srcl4port

This command adds to the specified class definition a match condition based on the source layer 4 port of a packet using a single keyword or numeric notation or a numeric range notation.

To specify the match condition as a single keyword notation, the value for <portkey> is one of the supported port name keywords (listed below).

The currently supported <portkey> values are: **domain, echo, ftp, ftpdata, http, smtp, snmp, telnet, tftp, www**. Each of these translates into its equivalent port number, which is used as both the start and end of a port range.

To specify the match condition as a numeric value, one layer 4 port number is required. The portnumber is an integer from 0 to 65535.

To specify the match condition as a range, two layer 4 port numbers are required and together they specify a contiguous port range. Each port number is an integer from 0 to 65535, but with the added requirement that the second number be equal to or greater than the first. The optional **[not]** parameter has the effect of negating this match condition for the class (i.e., match all source layer 4 ports except for those within the range specified here).

The optional **[not]** parameter has the effect of negating this match condition for the class (i.e., match all source layer 4 port numbers except for the one specified here).

Default	None
Format	match [not] srcl4port {portkey <0-65535>} [0-65535]
Mode	Class-Map Config

9.4.17 match vlan

This command adds to the specified class definition a match condition based on the value of the layer 2 VLAN Identifier field (the only tag in a single tagged packet or the first or outer tag of a double VLAN tagged packet). The VLAN ID is an integer from 1 to 4095. The optional **[not]** parameter has the effect of negating this match condition for the class (i.e., match all VLAN Identifier values except for what is specified here).

Default	None
Format	match [not] vlan <1-4095>

Mode

Class-Map Config

9.5 Policy Commands

The 'policy' command set is used in DiffServ to define:

Traffic Conditioning Specify traffic conditioning actions (policing, marking, shaping) to apply to traffic classes

The policy commands are used to associate a traffic class, which was defined by the class command set, with one or more QoS policy attributes. This association is then assigned to an interface to form a service. The user specifies the policy name when the policy is created.

The DiffServ CLI does not necessarily require that users associate only one traffic class to one policy. In fact, multiple traffic classes can be associated with a single policy, each defining a particular treatment for packets that match the class definition. When a packet satisfies the conditions of more than one class, preference is based on the order in which the classes were added to the policy, with the foremost class taking highest precedence.

This set of commands consists of policy creation/deletion, class addition/removal, and individual policy attributes. Note that the only way to remove an individual policy attribute from a class instance within a policy is to remove the class instance and re-add it to the policy. The values associated with an existing policy attribute can be changed without removing the class instance.

Note: Only the most recently added

The CLI command root is **policy-map**.

9.5.1 *assign-queue*

This command modifies the queue id to which the associated traffic stream is assigned. The queueid is an integer from 0 to n-1, where n is the number of egress queues supported by the device.

Format	assign-queue <queueid>
Mode	Policy-Class-Map Config
Incompatibilities	Drop

9.5.2 *drop*

This command specifies that all packets for the associated traffic stream are to be dropped at ingress.

Format	drop
Mode	Policy-Class-Map Config
Incompatibilities	Assign Queue, Mark (all forms), Police (all forms)

9.5.3 *redirect*

This command specifies that all incoming packets for the associated traffic stream are redirected to a specific egress interface (physical port or port-channel).

Format	redirect <unit/slot/port>
---------------	---------------------------

Mode	Policy-Class-Map Config
Incompatibilities	Drop

9.5.4 conform-color

This command is used to enable color-aware traffic policing and define the conform-color and exceed-color class maps used. Used in conjunction with the police command where the fields for the conform level (for simple, single-rate, and two-rate policing) and optionally the exceed level (for single-rate and two-rate policing) are specified. The **<class-map-name>** parameter is the name of an existing Diffserv class map, where different ones must be used for the conform and exceed colors.

Note: This command may only be used after specifying a police command for the policy-class instance.

Format conform-color <class-map-name> [exceed-color <class-map-name>]

Mode Policy-Class-Map Config

9.5.5 class

This command creates an instance of a class definition within the specified policy for the purpose of defining treatment of the traffic class through subsequent policy attribute statements. The **<classname>** is the name of an existing DiffServ class.

Note: This command causes the specified policy to create a reference to the class definition.

Note: The CLI mode is changed to Policy-classmap Config when this command is successfully executed.

Format class <classname>

Mode Policy-Map Config

9.5.5.1 no class

This command deletes the instance of a particular class and its defined treatment from the specified policy. **<classname>** is the names of an existing DiffServ class.

Note: This command removes the reference to the class definition for the specified policy.

Format no class <classname>

Mode Policy-Map Config

9.5.6 mark cos

This command marks all packets for the associated traffic stream with the specified class of servicevalue in the priority field of the 802.1p header (the only tag in a single tagged packet or the first or outer 802.1Q tag of a double VLAN tagged packet). If the packet does not already contain this header, one is inserted. The CoS value is an integer from 0 to 7.

Default 1
Format mark-cos <0-7>
Mode Policy-class-Map Config
Policy Type In

9.5.7 mark ip-dscp

This command marks all packets for the associated traffic stream with the specified IP DSCP value. The <dscpval> value is specified as either an integer from 0 to 63, or symbolically through one of the following keywords: *af11, af12, af13, af21, af22, af23, af31, af32, af33, af41, af42, af43, be, cs0, cs1, cs2, cs3, cs4, cs5, cs6, cs7, ef*.

Format mark ip-dscp <dscpval>
Mode Policy-classmap Config
Policy Type In
Incompatibilities Mark IP Precedence, Police (all forms)

9.5.8 mark ip-precedence

This command marks all packets for the associated traffic stream with the specified IP Precedence value. The IP Precedence value is an integer from 0 to 7.

Format mark ip-precedence <0-7>
Mode Policy-classmap Config
Policy Type In
Incompatibilities Mark IP DSCP, Police (all forms)

9.5.9 police-simple

This command is used to establish the traffic policing style for the specified class. The simple form of the police command uses a single data rate and burst size, resulting in two outcomes: conform and violate. The conforming data rate is specified in kilobits-per-second (Kbps) and is an integer from 1 to 4294967295. The conforming burst size is specified in kilobytes (KB) and is an integer from 1 to 128.

For each outcome, the only possible actions are drop, set-cos-transmit, set-sec-cos-transmit, set-dscptransmit, set-prec-transmit, or transmit. In this simple form of the police command, the conform action defaults to transmit and the violate action defaults to drop. These actions can be set

with this command once the style has been configured.

For set-dscp-transmit, a **<dscpval>** value is required and is specified as either an integer from 0 to 63, or symbolically through one of the following keywords: af11, af12, af13, af21, af22, af23, af31, af32, af33, af41, af42, af43, be, cs0, cs1, cs2, cs3, cs4, cs5, cs6, cs7, ef.

For set-prec-transmit, an IP Precedence value is required and is specified as an integer from 0-7.

For set-cos-transmit or set-secondary-cos-transmit, an 802.1p priority value is required and is specified as an integer from 0-7.

Format police-simple {<1-4294967295> <1-128> conform-action {drop | set-prec-transmit <0-7> | set-dscp-transmit <0-63> | set-cos-transmit <0-7> | set-secondary-cos-transmit <0-7> | transmit} [violate-action {drop | set-prec-transmit <0-7> | set-dscp-transmit <0-63> | set-cos-transmit <0-7> | set-secondary-cos-transmit <0-7> | transmit}]}

Mode Policy-classmap Config

Restrictions Only one style of police command (simple, singlerate, tworate) is allowed for a given class instance in a particular policy. Policy Type In

Incompatibilities Drop, Mark (all forms)

9.5.10 policy-map

This command establishes a new DiffServ policy. The **<policyname>** parameter is a case-sensitive alphanumeric string from 1 to 31 characters uniquely identifying the policy. The type of policy is specific to the inbound traffic direction as indicated by the **in** parameter.

Note: The policy type dictates which of the individual policy attribute commands are valid within the policy definition.

Note: The CLI mode is changed to Policy-Map Config when this command is successfully executed.

Format policy-map <policyname> <in | out> in

Mode Global Config

9.5.10.1 no policy-map

This command eliminates an existing DiffServ policy. The **<policyname>** parameter is the name of an existing DiffServ policy. This command may be issued at any time. If the policy is currently referenced by one or more interface service attachments, this delete attempt fails.

Format no policy-map <policyname>

Mode Global Config

9.5.11 policy-map rename

This command changes the name of a DiffServ policy. The **<policyname>** is the name of an existing DiffServ class. The **<newpolicyname>** parameter is a case-sensitive alphanumeric string from 1 to 31 characters uniquely identifying the policy.

Format policy-map rename <policyname> <newpolicyname>

Mode Global Config

9.6 Service Commands

The 'service' command set is used in DiffServ to define:

Traffic Conditioning Assign a DiffServ traffic conditioning policy (as specified by the policy commands) to an interface in the incoming direction

The service commands attach a defined policy to a directional interface. Only one policy may be assigned at any one time to an interface in the inbound direction. The policy type (in) must match the interface direction to which it is attached.

This set of commands consists of service addition/removal.

The CLI command root is *service-policy*

9.6.1 *service-policy*

This command attaches a policy to an interface in the inbound direction. The command can be used in the **Interface Config** mode to attach a policy to a specific interface. Alternatively, the command can be used in the **Global Config** mode to attach this policy to all system interfaces. The direction value is "in". The *<polycyname>* parameter is the name of an existing DiffServ policy, whose type must match the interface direction. This command causes a service to create a reference to the policy.

Note: This command effectively enables DiffServ on an interface (in a particular direction). There is no separate interface administrative 'mode' command for DiffServ.

Note: This command shall fail if any attributes within the policy definition exceed the capabilities of the interface. Once a policy is successfully attached to an interface, any attempt to change the policy definition such that it would result in a violation of said interface capabilities shall cause the policy change attempt to fail.

Format service-policy in <polycyname>

Modes Global Config (for all system interfaces) Interface Config (for a specific interface)

Restrictions Only a single policy may be attached to a particular interface in a particular direction at any one time.

9.6.1.1 *no service-policy*

This command detaches a policy from an interface in a particular direction. The command can be used in the Interface Config mode to detach a policy from a specific interface. Alternatively, the command can be used in the Global Config mode to detach this policy from all system interfaces to which it is currently attached. The direction value is either in or out. The *<polycyname>* parameter is the name of an existing DiffServ policy. Note that this command causes a service to remove its reference to the policy.

Note: This command effectively disables DiffServ on an interface (in a particular direction). There is no separate interface administrative 'mode' command for DiffServ.

Format no service-policy in <polycyname>

Modes Global Config (for all system interfaces) Interface Config (for a specific interface)

9.7 Show Commands

The 'show' command set is used in DiffServ to display configuration and status information for:

- Classes □
- Policies □
- Services

This information can be displayed in either summary or detailed formats. The status information is only shown when the DiffServ administrative mode is enabled; it is suppressed otherwise.

There is also a 'show' command for general DiffServ information that is available at any time.

9.7.1 *show class-map*

This command displays all configuration information for the specified class. The **<classname>** is the name of an existing DiffServ class.

Format show class-map *<classname>*

Mode Privileged EXEC User EXEC

If the Class Name is specified the following fields are displayed:

Class Name The name of this class.

Class Type The class type (all, any, or acl) indicating how the match criteria are evaluated for this class. A class type of all means every match criterion defined for the class is evaluated simultaneously they must all be true to indicate a class match. For a type of any each match criterion is evaluated sequentially and only one need be true to indicate a class match. Class type acl rules are evaluated in a hybrid manner, with those derived from each ACL Rule grouped and evaluated simultaneously, while each such grouping is evaluated sequentially.

Match Criteria The Match Criteria fields are only be displayed if they have been configured. They are displayed in the order entered by the user. The fields are evaluated in accordance with the class type. The possible Match Criteria fields are: Class of Service, COS, Destination IP Address, Destination Layer 4 Port, Destination MAC Address, Ether-type, Every, IP DSCP, IP Precedence, IP TOS, Protocol Keyword, Reference Class, Secondary COS, Secondary VLAN, Source IP Address, Source Layer 4 Port, Source MAC Address, VLAN.

Values This field displays the values of the Match Criteria.

Excluded This field indicates whether or not this Match Criteria is excluded.

If the Class Name is not specified, this command displays a list of all defined DiffServ classes. The following fields are displayed:

Class Name The name of this class. (Note that the order in which classes are displayed is not necessarily the same order in which they were created.)

Class Type The class type (all, any, or acl) indicating how the match criteria are evaluated for this class. A class type of all means every match criterion defined for the class is evaluated simultaneously they must all be true to indicate a class match. For a type of any each match criterion is evaluated sequentially and only one

need be true to indicate a class match. Class type acl rules are evaluated in a hybrid manner, with those derived from each ACL Rule grouped and evaluated simultaneously, while each such grouping is evaluated sequentially.

ACL Number The ACL number used to define the class match conditions at the time the class was created. This field is only meaningful if the class type is acl. (Note that the contents of the ACL may have changed since this class was created.)

Ref Class Name The name of an existing DiffServ class whose match conditions are being referenced by the specified class definition.

9.7.2 show diffserv

This command displays the DiffServ General Status Group information, which includes the current administrative mode setting as well as the current and maximum number of rows in each of the main DiffServ private MIB tables. This command takes no options.

Format	show diffservMode Privileged EXEC
DiffServ Admin mode	The current value of the DiffServ administrative mode.
Class Table Size	The current number of entries (rows) in the Class Table.
Class Table Max	The maximum allowed entries (rows) for the Class Table.
Class Rule Table Size	The current number of entries (rows) in the Class Rule Table.
Class Rule Table Max	The maximum allowed entries (rows) for the Class Rule Table.
Policy Table Size	The current number of entries (rows) in the Policy Table.
Policy Table Max	The maximum allowed entries (rows) for the Policy Table.
Policy Instance Table Size	The current number of entries (rows) in the Policy Instance Table.
Policy Instance Table Max	The maximum allowed entries (rows) for the Policy Instance Table.
Policy Attribute Table Size	The current number of entries (rows) in the Policy Attribute Table.
Policy Attribute Table Max	The maximum allowed entries (rows) for the Policy Attribute Table.
Service Table Size	The current number of entries (rows) in the Service Table.
Service Table Max	The maximum allowed entries (rows) for the Service Table.

9.7.3 show policy-map

This command displays all configuration information for the specified policy. The <policyname> is the name of an existing DiffServ policy.

Format show policy-map [*policyname*]

Mode Privileged EXEC

If the Policy Name is specified the following fields are displayed:

Policy Name The name of this policy.

Type The policy type, namely whether it is an inbound or outbound policy definition.

The following information is repeated for each class associated with this policy (only those policy attributes actually configured are displayed):

Assign Queue Directs traffic stream to the specified QoS queue. This allows a traffic classifier to specify which one of the supported hardware queues are used for handling packets belonging to the class.

Class Name The name of this class.

Committed Burst Size (KB) This field displays the committed burst size, used in simple policing, single-rate policing, and two-rate policing.

Committed Rate (Kbps) This field displays the committed rate, used in simple policing, single-rate policing, and two-rate policing.

Conform Action The current setting for the action taken on a packet considered to conform to the policing parameters. This is not displayed if policing is not in use for the class under this policy.

Conform COS The action to be taken on conforming packets per the policing metrics.

Conform DSCP Value This field shows the DSCP mark value if the conform action is markdscp.

Conform IP Precedence Value This field shows the IP Precedence mark value if the conform action is markprec.

Conform Secondary COS The action to be taken on packets conforming with the secondary class of service value per the policing metrics.

Drop Drop a packet upon arrival. This is useful for emulating access control list operation using DiffServ, especially when DiffServ and ACL cannot co-exist on the same interface.

Exceed Action The current setting for the action taken on a packet considered to exceed to the policing parameters. This is not displayed if policing not in use for the class under this policy.

Exceed COS The action to be taken on excess packets per the policing metrics.

Exceed DSCP Value This field shows the DSCP mark value if this action is markdscp.

Exceed IP Precedence Value This field shows the IP Precedence mark value if this action is markprec.

Exceed Secondary COS The action to be taken on excess packets conforming with the secondary class of service value per the policing metrics.

Excess Burst Size (KB) This field displays the excess burst size, used in single-rate policing.

Mark CoS Denotes the class of service value that is set in the 802.1p header of outbound packets. This is not displayed if the mark cos was not specified.

Mark IP DSCP Denotes the mark/re-mark value used as the DSCP for traffic matching this class. This is not displayed if mark ip description is not specified using the police-two-rate command, or if policing is in use for the class under this policy.

Mark IP Precedence Denotes the mark/re-mark value used as the IP Precedence for traffic matching this class. This is not displayed if precedence is not specified using police-tworate command, or if either mark DSCP or policing is in use for the class under this policy.

Mark Secondary COS Denotes the secondary class of service value that is set in the 802.1p header of outbound packets. This is not displayed if the mark secondary-cos was not specified.

Non-Conform Action The current setting for the action taken on a packet considered to not conform to the policing parameters. This is not displayed if policing not in use for the class under this policy.

Non-Conform COS The action to be taken on violating packets per the policing metric.

Non-Conform DSCP Value This field displays the DSCP mark value if this action is

markdscp.

Non-Conform IP Precedence Value This field displays the IP Precedence mark value if this action is markprec.

Non-Conform Secondary COS The action to be taken on violating packets conforming with the secondary class of service per the policing metric.

Peak Burst Size (KB) This field displays the peak burst size, used in two-rate policing.

Peak Rate (Kbps) This field displays the peak rate, used in two-rate policing.

Policing Style This field denotes the style of policing, if any, used (simple, single rate, or two rate).

Redirect Forces a classified traffic stream to a specified egress port (physical or LAG). This can occur in addition to any marking or policing action. It may also be specified along with a QoS queue assignment.

If the Policy Name is not specified this command displays a list of all defined DiffServ policies. The following fields are displayed:

Policy Name The name of this policy. (Note that the order in which the policies are displayed is not necessarily the same order in which they were created.)

Policy Type The policy type, namely whether it is an inbound or outbound policy definition.

Class Members List of all class names associated with this policy.

9.7.4 show diffserv service

This command displays policy service information for the specified interface and direction. The <unit/ slot/port> parameter specifies a valid unit/slot/port number for the system. The direction parameter indicates the interface direction of interest.

Format show diffserv service <unit/slot/port> {in}

Mode Privileged EXEC

DiffServ Admin Mode The current setting of the DiffServ administrative mode. An attached policy is only in effect on an interface while DiffServ is in an enabled mode.

Interface Valid unit, slot and port number separated by forward slashes.

Direction The traffic direction of this interface service.

Operational Status The current operational status of this DiffServ service interface.

Policy Name The name of the policy attached to the interface in the indicated direction.

Policy Details Attached policy details, whose content is identical to that described for the show policy-map <policy-mapname> command (content not repeated here for brevity).

9.7.5 show diffserv service brief

This command displays all interfaces in the system to which a DiffServ policy has been attached. The direction parameter is optional; if specified, only services in the indicated direction are shown, otherwise service information is shown for both directions, where applicable.

Format show diffserv service brief {in}

Mode Privileged EXEC

DiffServ Mode The current setting of the DiffServ administrative mode. An attached policy is only active

on an interface while DiffServ is in an enabled mode.

The following information is repeated for interface and direction (only those interfaces configured with an attached policy are shown):

Interface	Valid unit, slot and port number separated by forward slashes.
Direction	The traffic direction of this interface service.
OperStatus	The current operational status of this DiffServ service interface.
Policy Name	The name of the policy attached to the interface in the indicated direction.

9.7.6 *show policy-map interface*

This command displays policy-oriented statistics information for the specified interface and direction. The <unit/slot/port> parameter specifies a valid interface for the system.

Note: This command is only allowed while the DiffServ administrative mode is enabled.

Format show policy-map interface <unit/slot/port> {in}

Mode Privileged EXEC

Interface Valid unit, slot and port number separated by forward slashes.

Direction The traffic direction of this interface service.

Operational Status The current operational status of this DiffServ service interface.

Policy Name The name of the policy attached to the interface in the indicated direction.

Interface Offered Octets/Packets A cumulative count of the octets/packets offered to this service interface in the specified direction before the defined DiffServ treatment is applied.

Interface Discarded Octets/Packets A cumulative count of the octets/packets discarded by this service interface in the specified direction for any reason due to DiffServ treatment.

Interface Sent Octets/Packets A cumulative count of the octets/packets forwarded by this service interface in the specified direction after the defined DiffServ treatment was applied. In this case, forwarding means the traffic stream was passed to the next functional element in the data path, such as the switching or routing function or an outbound link transmission element.

The following information is repeated for each class instance within this policy:

Class Name The name of this class instance.

In Offered Octets/Packets A count of the octets/packets offered to this class instance before the defined DiffServ treatment is applied. Only displayed for the 'in' direction.

In Discarded Octets/Packets A count of the octets/packets discarded for this class instance for any reason due to DiffServ treatment of the traffic class. Only displayed for the 'in' direction.

Note: None of the counters listed here are guaranteed to be supported on all platforms. Only supported counters are shown in the display output.

9.7.7 show service-policy

This command displays a summary of policy-oriented statistics information for all interfaces in the specified direction.

Format show service-policy in

Mode Privileged EXEC

The following information is repeated for each interface and direction (only those interfaces configured with an attached policy are shown):

Interface Valid unit, slot and port number separated by forward slashes.

Dir The traffic direction of this interface service.

Operational Status The current operational status of this DiffServ service interface.

Offered Packets A count of the total number of packets offered to all class instances in this service before their defined DiffServ treatment is applied. These are overall per-interface per-direction counts.

Discarded Packets A count of the total number of packets discarded for all class instances in this service for any reason due to DiffServ treatment. These are overall per-interface per-direction counts.

Sent Packets A count of the total number of packets forwarded for all class instances in this service after their defined DiffServ treatments were applied. In this case, forwarding means the traffic stream was passed to the next functional element in the data path, such as the switching or routing function or an outbound link transmission element. These are overall per-interface per-direction counts.

Policy Name The name of the policy attached to the interface.

Note: None of the counters listed here are guaranteed to be supported on all platforms. Only supported counters are shown in the display output.

9.8 Class of Service (CoS) Commands

This chapter provides a detailed explanation of the switch's QoS CoS commands. The following commands are available in the switch's QoS module.

The commands are divided into these different groups:

- Configuration Commands are used to configure features and options of the switch. For every configuration command there is a show command that will display the configuration setting.
- Show commands are used to display device settings, statistics and other information.

Note: The 'Interface Config' mode only affects a single interface, whereas the 'Global Con-fig' mode is applied to all interfaces.

9.8.1 *classofservice dot1p-mapping*

This command maps an 802.1p priority to an internal traffic class. The userpriority and trafficclass can both range from 0-7, although the actual number of available traffic classes depends on the platform. The 'no' form of this command is not supported.

Format classofservice dot1p-mapping <userpriority> <trafficclass>

Modes Global Config Interface Config

9.8.2 *classofservice ip-dscp-mapping*

This command maps an IP DSCP value to an internal traffic class. The ipdscp range is from 0-63 and the trafficclass range is from 0-7, although the actual number of available traffic classes depends on the platform. The 'no' form of this command is not supported.

Format classofservice ip-dscp-mapping <ipdscp> <trafficclass>

Modes Global Config Interface Config

9.8.3 *classofservice ip-precedence-mapping*

This command maps an IP precedence value to an internal traffic class. The ipprecedence and trafficclass can both range from 0-7, although the actual number of available traffic classes depends on the platform. The 'no' form of this command is not supported.

Format classofservice ip-precedence-mapping <ipprecedence> <traffic-class>

Modes Global Config Interface Config

9.8.4 *classofservice trust*

This command sets the class of service trust mode of an interface. The mode can be set to trust one of the Dot1p (802.1p), IP Precedence, or IP DSCP packet markings.

Format classofservice trust <dot1p/ip-precedence/ip-dscp>

Mode Global Config Interface Config

Note: the “ip-precedence” parameter is adapted for Layer 2 & Layer 3 Switch Series

9.8.4.1 *no classofservice trust*

This command sets the interface mode to untrusted.

Format no classofservice trust

Modes Global Config Interface Config

9.8.5 *cos-queue wfq min-bandwidth*

This command configures the WFQ minimum bandwidth for an interface. The min-bandwidth value should be in the multiples of 64 Kbps and minimum value is 64 Kbps. If other than multiples of 64 is specified then it is rounded to nearest multiple of 64.

Format cos-queue wfq min-bandwidth <bw-0>..<>

Mode Global Config, Interface Config

9.8.6 *cos-queue wrr wrr-weights*

This command specifies the weighted round-robin queuing scheduler mode for each interface queue. The valid range of values for the weights is 1 to 15.

Format cos-queue wrr wrr-weights <wt-0>..<>

Mode Global Config, Interface Config

9.8.6.1 *no cos-queue min-bandwidth*

This command restores the default of the weighted round-robin queuing scheduler mode for each queue's minimum bandwidth value.

Format no cos-queue wrr wrr-weights

Mode Global Config, Interface Config

9.8.7 *cos-queue strict*

This command activates the strict priority scheduler mode for each specified queue.

Format cos-queue strict <queue-id> [<queue-id> [<queue-id> [<queue-id> [<queue-id> [<queue-id> [<queue-id> [<queue-id>]]]]]]]]]]

Mode Global Config, Interface Config

9.8.7.1 *no cos-queue strict*

This command restores the default weighted scheduler mode for each specified queue.

Format no cos-queue strict <queue-id> [<queue-id> [<queue-id> [<queue-id> [<queue-id> [<queue-id> [<queue-id>]]]]]]]]

Mode Global Config, Interface Config

9.8.8 show classofservice dot1p-mapping

This command displays the current Dot1p (802.1p) priority mapping to internal traffic classes for a specific interface. The unit/slot/port parameter is optional and is only valid on platforms that support independent per-port class of service mappings. If specified, the 802.1p mapping table of the interface is displayed. If omitted, the most recent global configuration settings are displayed.

Format show classofservice dot1p-mapping [unit/slot/port]

Mode Privileged EXEC

The following information is repeated for each user priority.

User Priority The 802.1p user priority value.

Traffic Class The traffic class internal queue identifier to which the user priority value is mapped.

9.8.9 show classofservice ip-dscp-mapping

This command displays the current IP DSCP mapping to internal traffic classes for a specific interface.

The <unit/slot/port> is optional and is only valid on platforms that support independent per-port class of service mappings. If the <unit/slot/port> is specified, the IP DSCP mapping table of the interface is displayed. If the <unit/slot/port> is omitted, the most recent global configuration settings are displayed.

Note: The global configuration settings do not take precedence over the per-port configuration settings.

Format show classofservice ip-dscp-mapping[unit/slot/port]

Mode Privileged EXEC

The following information is repeated for each user priority.

IP DSCP The IP DSCP value.

Traffic Class The traffic class internal queue identifier to which the IP DSCP value is mapped.

9.8.10 show classofservice ip-precedence-mapping

This command displays the current IP Precedence mapping to internal traffic classes for a specific interface. The unit/slot/port parameter is optional and is only valid on platforms that support independent per-port class of service mappings. If specified, the IP Precedence mapping table of the interface is displayed. If omitted, the most recent global configuration settings are displayed.

Format show classofservice ip-precedence-mapping [unit/slot/port]

Mode Privileged EXEC

The following information is repeated for each user priority.

IP Precedence The IP Precedence value.

Traffic Class The traffic class internal queue identifier to which the IP Precedence value is mapped.

9.8.11 *show classofservice trust*

This command displays the current trust mode setting for a specific interface. The unit/slot/port parameter is optional and is only valid on platforms that support independent per-port class of service mappings. If specified, the port trust mode of the interface is displayed. If omitted, the most recent global configuration settings are displayed.

Format show classofservice trust [unit/slot/port]

Mode Privileged EXEC

Non-IP Traffic Class The traffic class used for non-IP traffic. This is only displayed when the COS trust mode is set to either 'trust ip-dscp' or 'trust ip-precedence'.

Untrusted Traffic Class The traffic class used for all untrusted traffic. This is only displayed when the COS trust mode is set to 'untrusted'.

9.8.12 *show interfaces cos-queue*

This command displays the class-of-service queue configuration for the specified interface. The unit/ slot/port parameter is optional and is only valid on platforms that support independent per-port class of service mappings. If specified, the class-of-service queue configuration of the interface is displayed. If omitted, the most recent global configuration settings are displayed.

Format show interfaces cos-queue [unit/slot/port]

Mode Privileged EXEC

Interface This displays the unit/slot/port of the interface. If displaying the global configuration, this output line is replaced with a Global Config indication.

Intf Shaping Rate The maximum transmission bandwidth limit for the interface as a whole. It is independent of any per-queue maximum bandwidth value(s) in effect for the interface. This is a configured value.

Queue Mgmt Type The queue depth management technique used for all queues on this interface, either tail drop or weighted random early discard (WRED). This is only displayed if the platform does not support per-queue configuration of the queue management type. This is a configured value.

WRED Decay Exponent The weighted random early discard (WRED) average queue length calculation decay exponent. This is a configured value.

The following information is repeated for each queue on the interface.

Queue Id An interface supports n queues numbered 0 to (n-1). The specific n value is platform dependent.

Minimum Bandwidth The minimum transmission bandwidth guarantee for the queue, expressed as a percentage. A value of 0 means bandwidth is not guaranteed and the queue

operates using best-effort. This is a configured value.

Maximum Bandwidth The maximum transmission bandwidth limit for the queue, expressed as a percentage. A value of 0 means no upper limit is enforced, so the queue may use any or all of the available bandwidth of the interface. This is a configured value.

Scheduler Type Indicates whether this queue is scheduled for transmission using a strict priority or a weighted scheme. This is a configured value.

Queue Mgmt Type The queue depth management technique used for this queue, either tail drop or weighted random early discard (WRED). This is a configured value.

9.9 Rate-Limiting Commands

9.9.1 *rate-limiting*

This command is used to set the bandwidth of a specified interface. The type of rate limiting is specific to either the inbound or outbound traffic direction as indicated by the **{ingress | egress}** parameter. The **<limit>** parameter defines the value of bandwidth in megabit-per-second (Mbps). The granularity of bandwidth for the 10/100 interface is 1 Mbps and for the gigabit interface is 8 Mbps.

Format `rate-limiting {ingress | egress} <limit>`
Mode Interface Config

9.9.1.1 *no rate-limiting*

This command removes the bandwidth limitation of specified interface.

Format `no rate-limiting {ingress | egress}`
Mode Interface Config

9.9.2 *show rate-limiting*

This command displays the bandwidth of limiting in both ingress and egress direction for one or all interface

Format `show rate-limiting {<slot/port> | all}`
Mode Privileged EXEC and User EXEC

10.0 Stacking Commands

This chapter provides a detailed explanation of the Stacking commands.

Note: The following commands are applied “only“ on the Layer 2 Stackable Switch.

10.1 Dedicated-port Stacking

This section provides detailed explanations of the dedicated-port stacking commands. The commands are divided into two functional groups:

- Show commands display stacking settings, statistics and other information.
- Configuration commands configure features and options of the switch. For every configuration command there is a show command that displays the configuration setting.

10.1.1 *show supported swichtype*

This commands displays information about all supported switch types.

Format `show supported swichtype`

Mode `User Exec Switch`

Index (SID) This field displays the index into the database of supported switch types. This index is used when pre-configuring a member to be added to the stack.

Model Identifier This field displays the model identifier for the supported switch type.

Management Preference This field indicates the management preference value of the switch type.

Code Version This field displays the code load target identifier of the switch type.

10.1.1.1 *show supported swichtype*

This commands displays information about a requested switch type.

Format `show supported swichtype [switchindex]`

Mode `User Exec`

Switch Type This field displays the 32-bit numeric switch type for the supported switch.

Model Identifier This field displays the model identifier for the supported switch type.

Switch Description This field displays the description for the supported switch type.

10.1.2 member

This command configures a switch. The **<unit>** is the switch identifier of the switch to be added/removed from the stack. The **<switchindex>** is the index into the database of the supported switch types, indicating the type of the switch being pre-configured. The switch index is a 32-bit integer. This command is executed on the Primary Management Unit.

Format member <unit> <switchindex>

Mode Stack Global Config

Note: Switch index can be obtained by executing the show supported switchtype command in User Exec mode.

10.1.2.1 no member

This command removes a switch from the stack. The **<unit>** is the switch identifier of the switch to be removed from the stack. This command is executed on the Primary Management Unit.

Format no member <unit>

Mode Stack Global Config

10.1.3 switch priority

This command configures the ability of a switch to become the Primary Management Unit. The **<unit>** is the switch identifier. The **<value>** is the preference parameter that allows the user to specify, priority of one backup switch over another. The range for priority is 1 to 15. The switch with the highest priority value will be chosen to become the Primary Management Unit if the active Primary Management Unit fails. The switch priority defaults to the hardware management preference value 1. Switches that do not have the hardware capability to become the Primary Management Unit are not eligible for management.

Default enable

Format switch <unit> priority <value>

Mode Global Config

10.1.4 switch renumber

This command changes the switch identifier for a switch in the stack. The **<oldunit>** is the current switch identifier on the switch whose identifier is to be changed. The **<newunit>** is the updated value of the switch identifier. Upon execution, the switch will be configured with the configuration information for the new switch, if any. The old switch configuration information will be retained, however the old switch will be operationally unplugged. This command is executed on the Primary Management Unit.

Format switch <oldunit> renumber <newunit>

Mode Global Config

10.1.5 movemanagement

This command moves the Primary Management Unit functionality from one switch to another. The **<fromunit>** is the switch identifier on the current Primary Management Unit. The **<tounit>** is the switch identifier on the new Primary Management Unit. Upon execution, the entire stack (including all interfaces in the stack) will be un-configured and reconfigured with the configuration on the new Primary Management Unit. After the reload is complete, all stack management capability must be performed on the new Primary Management Unit. To preserve the current configuration across a stack move, execute the **copyconfig** command before performing the stack move. A stack move will cause all routes and layer 2 addresses to be lost. This command is executed on the Primary Management Unit. The administrator is prompted to confirm the management move.

Format `movemanagement <fromunit> <tounit>`

Mode Stack Global Config

10.1.6 archive copy-sw

This command replicates the STK file from the Primary Management Unit to the other switch(es) in the stack. The code is loaded on the destination system **<unit>**, if specified, otherwise the code is loaded on all switches in the stack. Switch(es) must be reset for the new code to start running.

Format `archive copy-sw <destination-system <unit>>`

Mode Stack Global Config

10.1.7 archive download-sw

This command downloads the STK file to the switch. The **<url>** is the transfer mode. The switch must be reset for the new code to start running.

Format `archive download-sw <url>`

Mode Stack Global Config

10.1.8 slot

This command configures a slot in the system. The **<unit/slot/port>** is the slot identifier of the slot. The **<cardindex>** is the index into the database of the supported card types, indicating the type of the card being pre-configured in the specified slot. The card index is a 32-bit integer. If a card is currently present in the slot that is un-configured, the configured information will be deleted and the slot will be re-configured with default information for the card.

Format `slot <unit/slot/port> <cardindex>`

Mode Global Config

Note: Card index can be obtained by executing `show supported cardtype` command in User Exec mode.

10.1.8.1 no slot

This command removes configured information from an existing slot in the system.

Format `no slot <unit/slot/port> <cardindex>`

Mode Global Config

Note: Card index can be obtained by executing `show supported cardtype` command in the User-Exec mode.

10.1.9 set slot disable

This command configures the administrative mode of the slot(s). If **all** is specified the command is applied to all slots, otherwise the command is applied to the slot identified by unit/slot/port.

If a card or other module is present in the slot, this administrative mode will effectively be applied to the contents of the slot. If the slot is empty, this administrative mode will be applied to any module that is inserted into the slot. If a card is disabled, all the ports on the device are operationally disabled and shown as “unplugged” on management screens.

Format `set slot disable [<unit/slot/port> | all]`

Mode Global Config

10.1.9.1 no set slot disable

This command unconfigures the administrative mode of the slot(s). If **all** is specified the command removes the configuration from all slots, otherwise the configuration is removed from the slot identified by unit/slot/port.

If a card or other module is present in the slot, this administrative mode removes the configuration from the contents of the slot. If the slot is empty, this administrative mode removes the configuration from any module inserted into the slot. If a card is disabled, all the ports on the device are operationally disabled and shown as “unplugged” on management screens.

Format `no set slot disable [<unit/slot/port> | all]`

Mode Global Config

10.1.10 set slot power

This command configures the power mode of the slot(s) and allows power to be supplied to a card located in the slot. If **all** is specified the command is applied to all slots, otherwise the command is applied to the slot identified by unit/slot/port.

Use this command when installing or removing cards. If a card or other module is present in this slot, the power mode is applied to the contents of the slot. If the slot is empty, the power mode is applied to any card inserted into the slot.

Format `set slot power [<unit/slot/port> | all]`

Mode Global Config

10.1.10.1 no set slot power

This command un-configures the power mode of the slot(s) and prohibits power from being supplied to a card located in the slot. If **all** is specified the command prohibits power to all slots, otherwise the command prohibits power to the slot identified by unit/slot/port.

Use this command when installing or removing cards. If a card or other module is present in this

slot, power is prohibited to the contents of the slot. If the slot is empty, power is prohibited to any card inserted into the slot.

Format no set slot power [<unit/slot/port> | all]

Mode Global Config

10.1.11 show slot

This command displays information about all the slots in the system.

Format show slot

Mode User Exec

Slot This field displays the slot identifier in a unit/slot/port format.

Slot Status This field indicates whether the slot is empty, full, or has encountered an error.

Admin State This field displays the slot administrative mode as enabled or disabled.

Power State This field displays the slot power mode as enabled or disable

Configured Card Model Identifier This field displays the model identifier of the card pre-configured in the slot. Model Identifier is a 32-character field used to identify a card.

Pluggable This field indicates whether cards are pluggable or non-pluggable in the slot.

Power Down This field indicates whether the slot can be powered down.

10.1.11.1 show slot

This command displays information for the requested slot. If the slot holds a card or module, information about the contents of the slot is also displayed.

Format show slot <unit/slot/port>

Mode User Exec

Slot This field displays the slot identifier. In a stacking environment this field is displayed in a unit/slot/port format.

Slot Status This field indicates whether the slot is empty, full, or with error.

Admin State This field displays the slot administrative mode as enabled or disabled.

Power State This field displays the slot power mode as enabled or disabled.

Inserted Card Model Identifier This field displays the model identifier of the card inserted in the slot. Model Identifier is a 32-character field used to identify a card. This field is displayed only if the slot is full.

Inserted Card Description This field displays the card description. This field is displayed only if the slot is full.

Configured Card Model Identifier This field displays the model identifier of the card pre-configured in the slot. Model Identifier is a 32-character field used to identify a card. This field is displayed only if the slot is pre-configured.

Configured Card Description This field displays the card description. This field is displayed only if the slot is pre-configured.

Pluggable This field indicates whether cards are pluggable or non-pluggable in the slot.

Power Down This field indicates whether the slot can be powered down.

10.1.12 show supported cardtype

This command displays information about all card types supported in the system.

Format `show supported cardtype`

Mode **User Exec Card Index (CID)** This field displays the index into the database of the supported card types. This index is used when pre-configuring a slot.

Card Model Identifier This field displays the model identifier for the supported card type.

10.1.12.1 show supported cardtype [cardindex]

This command displays information about specific card types supported in the system.

Format `show supported cardtype <cardindex>`

Mode **User ExecCard Type**

This field displays the 32-bit numeric card type for the supported card.

Model Identifier This field displays the model identifier for the supported card type.

Card Description This field displays the description for the supported card type.

10.1.13 reload

This command resets the entire stack or the identified **[unit]**. The administrator is prompted to confirm that the reset should proceed.

Format `reload [unit]`

Mode **Global Config**

10.2 Front Panel Stacking

This section provides detailed explanations of the Front Panel Stacking commands. The commands are divided into two functional groups:

- Show commands display stacking settings, statistics and other information.
- Configuration commands configure features and options of the switch. For every configuration command there is a show command that displays the configuration setting.

10.2.1 *stack-port*

This command sets front panel stacking per port to either stack or ethernet mode

Default stack

Format `stack-port <unit/slot/port> [ethernet | stack]`

Mode Stack Global Config

10.2.2 *qos-mode*

This command enables QOS mode for front panel stacking.

Default enabled

Format `qos-mode`

Mode Stack Global Config

10.2.2.1 *no qos-mode*

This command disables QOS mode for front panel stacking.

Format `no qos-mode`

Mode Stack Global Config

11.0 Routing Commands

This chapter provides a detailed explanation of the Routing commands.

Note: The command in this chapter are applied only for Layer 3 Series.

11.1 Address Resolution Protocol (ARP) Commands

This chapter provides a detailed explanation of the ARP commands. The commands are divided by functionality into the following different groups:

- Show commands are used to display switch settings, statistics and other information.
- Configuration Commands are used to configure features and options of the switch. For every configuration command there is a show command that will display the configuration setting.
- Copy commands are used to transfer configuration and informational files to and from the switch.

11.1.1 *arp*

This command creates an ARP entry. The value for <ipaddress> is the IP address of a device on a subnet attached to an existing routing interface. <macaddr> is a unicast MAC address for that device.

The format is 6 two-digit hexadecimal numbers that are separated by colons, for example 00:06:29:32:81:40.

Format arp <ipaddress> <macaddr>

Mode Global Config

11.1.1.1 *no arp*

This command deletes an ARP entry. The value for <arpentry> is the IP address of the interface. The value for <ipaddress> is the IP address of a device on a subnet attached to an existing routing interface. <macaddr> is a unicast MAC address for that device.

Format no arp <ipaddress> <macaddr>

Mode Global Config

11.1.2 *ip proxy-arp*

This command enables proxy ARP on a router interface.

Without proxy ARP, a device only responds to an ARP request if the target IP address is an address configured on the interface where the ARP request arrived. With proxy ARP, the device may also respond if the target IP address is reachable. The device only responds if all next hops in

its route to the destination are through interfaces other than the interface that received the ARP request.

Default enabled
Format ip proxy-arp
Mode Interface Config

11.1.2.1 no ip proxy-arp

This command disables proxy ARP on a router interface.

Format no ip proxy-arp
Mode Interface Config

11.1.3 arp purge

This command causes the specified IP address to be removed from the ARP cache. Only entries of type dynamic or gateway are affected by this command.

Format arp purge <ipaddr>
Mode Privileged EXEC

11.1.4 arp dynamicrenew

This command enables ARP component to automatically renew ARP entries of type dynamic when they age out.

Format arp dynamicrenew
Mode Privileged Exec

11.1.4.1 no arp dynamicrenew

This command disables ARP component from automatically renewing ARP entries of type dynamic when they age out.

Format no arp dynamicrenew
Mode Privileged Exec

11.1.5 arp resptime

This command configures the ARP request response timeout. The value for <seconds> is a valid positive integer, which represents the IP ARP entry response timeout time in seconds. The range for <seconds> is between 1-10 seconds.

Default 1
Format arp resptime <1-10>
Mode Global Config

11.1.5.1 *no arp resptime*

This command configures the default ARP request response timeout.

Format no arp resptime

Mode Global Config

11.1.6 *arp retries*

This command configures the ARP count of maximum request for retries. The value for <retries> is an integer, which represents the maximum number of request for retries. The range for <retries> is an integer between 0-10 retries.

Default 4

Format arp retries <0-10>

Mode Global Config

11.1.6.1 *no arp retries*

This command configures the default ARP count of maximum request for retries.

Format no arp retries

Mode Global Config

11.1.7 *arp timeout*

This command configures the ARP entry ageout time. The value for <seconds> is a valid positive integer, which represents the IP ARP entry ageout time in seconds. The range for <seconds> is between 15-21600 seconds.

Default 1200

Format arp timeout <15-21600>

Mode Global Config

11.1.7.1 *no arp timeout*

This command configures the default ARP entry ageout time.

Format no arp timeout

Mode Global Config

11.1.8 *clear arp-cache*

This command causes all ARP entries of type dynamic to be removed from the ARP cache. If the *gateway* parameter is specified, the dynamic entries of type gateway are purged as well.

Format clear arp-cache [gateway]

Mode Privileged Exec

11.1.9 show arp

This command displays the Address Resolution Protocol (ARP) cache. The displayed results are not the total ARP entries. To view the total ARP entries, the operator should view the **show arp** results in conjunction with the **show arp switch** results.

Format show arp

Mode Privileged EXEC

Age Time (seconds) Is the time it takes for an ARP entry to age out. This value was configured into the unit. Age time is measured in seconds.

Response Time (seconds) Is the time it takes for an ARP request timeout. This value was configured into the unit. Response time is measured in seconds.

Retries Is the maximum number of times an ARP request is retried. This value was configured into the unit.

Cache Size Is the maximum number of entries in the ARP table. This value was configured into the unit.

Dynamic Renew Mode Displays whether the ARP component automatically attempts to renew dynamic ARP entries when they age out.

Total Entry Count Current / Peak Field listing the total entries in the ARP table and the peak entry count in the ARP table.

Static Entry Count Current / Max Field listing the static entry count in the ARP table and maximum static entry count in the ARP table.

The following are displayed for each ARP entry.

IP Address Is the IP address of a device on a subnet attached to an existing routing interface.

MAC Address Is the hardware MAC address of that device.

Interface Is the routing unit/slot/port associated with the device ARP entry.

Type Is the type that was configured into the unit. The possible values are Local, Gateway, Dynamic and Static.

Age This field displays the current age of the ARP entry since last refresh (in hh:mm:ss format)

11.1.10 show arp brief

This command displays the brief Address Resolution Protocol (ARP) table information.

Format show arp brief

Mode Privileged EXEC

Age Time (seconds) Is the time it takes for an ARP entry to age out. This value was configured into the unit. Age time is measured in seconds.

Response Time (seconds) Is the time it takes for an ARP request timeout. This value was configured into the unit. Response time is measured in seconds.

Retries Is the maximum number of times an ARP request is retried. This value was configured into the unit.

Cache Size Is the maximum number of entries in the ARP table. This value was configured into the unit.

Dynamic Renew Mode Displays whether the ARP component automatically attempts to renew dynamic ARP entries when they age out.

Total Entry Count Current / Peak Field listing the total entries in the ARP table and the peak entry count in the ARP table.

Static Entry Count Current / Max Field listing the static entry count in the ARP table and maximum static entry count in the ARP table.

11.2 IP Routing

This chapter provides a detailed explanation of the IP Routing commands. The commands are divided by functionality into the following different groups:

- Show commands are used to display switch settings, statistics and other information.
- Configuration Commands are used to configure features and options of the switch. For every configuration command there is a show command that will display the configuration setting.
- Copy commands are used to transfer configuration and informational files to and from the switch.

11.2.1 routing

This command enables routing for an interface. The current value for this function is displayed under "show ip interface" labeled as "Routing Mode".

Default	disabled
Format	routing
Mode	Interface Config

11.2.1.1 no routing

This command disables routing for an interface. The current value for this function is displayed under "show ip interface" labeled as "Routing Mode".

Format	no routing
Mode	Interface Config

11.2.2 ip routing

This command enables the IP Router Admin Mode for the master switch.

Format	ip routing
Mode	Global Config

11.2.2.1 no ip routing

This command disables the IP Router Admin Mode for the master switch.

Format	no ip routing
Mode	Global Config

11.2.3 ip address

This command configures an IP address on an interface. The IP address may be a secondary IP address.

The value for <ipaddr> is the IP Address of the interface.

The value for <subnetmask> is a 4-digit dotted-decimal number which represents the Subnet Mask of the interface. This changes the label "IP address" in "show ip interface."

Format ip address <ipaddr> <subnetmask> [secondary]

Mode Interface Config

11.2.3.1 no ip address

This command deletes an IP address from an interface. The value for <ipaddr> is the IP Address of the interface. The value for <subnetmask> is a 4-digit dotted-decimal number which represents the Subnet Mask of the interface.

Format no ip address <ipaddr> <subnetmask> [secondary]

Mode Interface Config

11.2.4 ip route

This command configures a static route. The <ip_addr> is a valid ip address. The <subnet_mask> is a valid subnet mask. The <nextHopRtr> is a valid IP address of the next hop router. The <preference> is an integer value from 1 to 255.

Default preference - 1

Format ip route <ip_addr> <subnet_mask> <nextHopRtr> [<preference>]

Mode Global Config

11.2.4.1 no ip route

This command deletes all next hops to a destination static route. If the optional <nextHopRtr> parameter is designated, the next hop is deleted and if the optional preference value is designated, the preference value of the static route is reset to its default,

Format no ip route <ip_addr> <subnet_mask> [{<nextHopRtr> | <preference>}]

Mode Global Config

11.2.5 ip route default

This command configures the default route. The value for <nextHopRtr> is a valid IP address of the next hop router. The <preference> is an integer value from 1 to 255

Default preference - 1

Format ip route default <nextHopRtr> [<preference>]

Mode Global Config

11.2.5.1 no ip route default

This command deletes all configured default routes. If the optional <nextHopRtr> parameter is designated, the specific next hop is deleted from the configured default route and if the optional preference value is designated, the preference of the configured default route is reset to its default.

Format no ip route default [{<nextHopRtr> | <preference>}]

Mode Global Config

11.2.6 *ip route distance*

This command sets the default distance for static routes. Lower route preference values are preferred when determining the best route. The "ip route" and "ip route default" commands allow you to optionally set the distance of an individual static route. The default distance is used when no distance is specified in these commands. Changing the default distance does not update the distance of existing static routes, even if they were assigned the original default distance. The new default distance will only be applied to static routes created after invoking the "ip route distance" command.

Default	1
Format	ip route distance <1-255>
Mode	Global Config

11.2.6.1 *no ip route distance*

This command sets the default static route preference value in the router. Lower route preference values are preferred when determining the best route.

Format	no ip route distance
Mode	Global Config

11.2.7 *ip forwarding*

This command enables forwarding of IP frames.

Default	enabled
Format	ip forwarding
Mode	Global Config

11.2.7.1 *no ip forwarding*

This command disables forwarding of IP frames.

Format	no ip forwarding
Mode	Global Config

11.2.8 *ip netdirbcast*

This command enables the forwarding of network-directed broadcasts. When enabled, network directed broadcasts are forwarded. When disabled they are dropped.

Default	disabled
Format	ip netdirbcast
Mode	Interface Config

11.2.8.1 *no ip netdirbcast*

This command disables the forwarding of network-directed broadcasts. When disabled, network directed broadcasts are dropped.

Format no ip netdirbcast

Mode Interface Config

11.2.9 ip mtu

This command sets the IP Maximum Transmission Unit (MTU) on a routing interface. The IP MTU is the size of the largest IP packet that can be transmitted on the interface without fragmentation. The switch currently does not fragment IP packets.

- Packets forwarded in hardware ignore the IP MTU. □Packets forwarded in software are dropped if they exceed the IP MTU of the outgoing interface.
- Packets originated on the router, such as OSPF packets, may be fragmented by the IP stack. The IP stack uses its default IP MTU and ignores the value set using the ip mtu command.

OSPF advertises the IP MTU in the Database Description packets it sends to its neighbors during database exchange. If two OSPF neighbors advertise different IP MTUs, they will not form adjacency (unless OSPF has been instructed to ignore differences in IP MTU with the ip ospf mtuignore command.)

Note: The IP MTU size refers to the maximum size of the IP packet (IP Header + IP payload). It does not include any extra bytes that may be required for Layer-2 headers. To receive and process packets, the Ethernet MTU (See “mtu” on page 32.) must take into account the size of the Ethernet header.

- The minimum IP MTU is 68 bytes.□
- The maximum IP MTU is 1500 bytes.

Default 1500 bytes

Format ip mtu <mtu>

Mode Interface Config

11.2.9.1 no ip mtu

This command resets the ip mtu to the default value.

Format no ip mtu <mtu>

Mode Interface Config

11.2.10 show ip brief

This command displays all the summary information of the IP. This command takes no options.

Format show ip brief

Modes Privileged EXEC User EXEC

Default Time to Live The computed TTL (Time to Live) of forwarding a packet from the local router to the final destination.

Router ID Is a 32 bit integer in dotted decimal format identifying the router, about which information is displayed. This is a configured value.

Routing Mode Shows whether the routing mode is enabled or disabled.

IP Forwarding Mode Shows whether forwarding of IP frames is enabled or disabled. This is a configured value.

11.2.11 *show ip interface*

This command displays all pertinent information about the IP interface.

Format show ip interface <unit/slot/port>

Modes Privileged EXEC User EXEC

IP Address Is an IP address representing the subnet configuration of the router interface. This value was configured into the unit.

Subnet Mask Is a mask of the network and host portion of the IP address for the router interface. This value was configured into the unit.

Routing Mode Is the administrative mode of router interface participation. The possible values are enable or disable. This value was configured into the unit.

Administrative Mode Is the administrative mode of the specified interface. The possible values of this field are enable or disable. This value was configured into the unit.

Forward Net Directed Broadcasts Displays whether forwarding of network-directed broadcasts is enabled or disabled. This value was configured into the unit.

Active State Displays whether the interface is active or inactive. An interface is considered active if its link is up and it is in forwarding state.

Link Speed Data Rate Is an integer representing the physical link data rate of the specified interface. This is measured in Megabits per second (Mbps).

MAC Address Is the burned in physical address of the specified interface. The format is 6 two-digit hexadecimal numbers that are separated by colons.

Encapsulation Type Is the encapsulation type for the specified interface. The types are: Ethernet or SNAP.

11.2.12 *show ip interface brief*

This command displays summary information about IP configuration settings for all ports in the router. This command takes no options.

Format show ip interface brief

Modes Privileged EXEC User EXEC

Interface Valid unit, slot and port number separated by forward slashes.

IP Address The IP address of the routing interface in 32-bit dotted decimal format.

IP Mask The IP mask of the routing interface in 32-bit dotted decimal format.

Netdir Bcast Indicates if IP forwards net-directed broadcasts on this interface. Possible values are Enable or Disable.

MultiCast Fwd Indicates the multicast forwarding administrative mode on the interface. Possible values are Enable or Disable.

11.2.13 *show ip route*

This command displays the entire route table. This command takes no options.

Format show ip route

Mode Privileged EXEC

Network Address Is an IP address identifying the network on the specified interface.

Subnet Mask Is a mask of the network and host portion of the IP address for the router interface.

Protocol Tells which protocol added the specified route. The possibilities are: local, static, OSPF or RIP.

Total Number of Routes The total number of routes.

For each Next Hop

Next Hop Intf The outgoing router interface to use when forwarding traffic to the next destination.

Next Hop IP Address The outgoing router IP address to use when forwarding traffic to the next router (if any) in the path toward the destination.

11.2.14 *show ip route bestroutes*

This command causes the entire route table to be displayed. This command takes no options.

Format show ip route bestroutes

Mode Privileged EXEC

Network Address Is an IP route prefix for the destination.

Subnet Mask Is a mask of the network and host portion of the IP address for the specified interface.

Protocol Tells which protocol added the specified route. The possibilities are: local, static, OSPF or RIP.

Total Number of Routes The total number of routes in the route table.

For each Next Hop

Next Hop Intf The outgoing router interface to use when forwarding traffic to the next destination.

Next Hop IP Address The outgoing router IP address to use when forwarding traffic to the next router (if any) in the path toward the destination. The next router will always be one of the adjacent neighbors or the IP address of the local interface for a directly attached network.

11.2.15 *show ip route entry*

This command displays the entire route table.

Format show ip route entry

Mode Privileged EXEC

Network Address Is a valid network address identifying the network on the specified interface.

Subnet Mask Is a mask of the network and host portion of the IP address for the attached network.

Protocol Tells which protocol added the specified route. The possibilities are: local, static, OSPF or RIP.

For each Next Hop

Next Hop Interface The outgoing router interface to use when forwarding traffic to the next destination.

Next Hop IP Address The outgoing router IP address to use when forwarding traffic to the next router (if any) in the path toward the destination.

Preference The metric value that is used for this route entry.

Metric

11.2.16 show ip route preferences

This command displays detailed information about the route preferences. Route preferences are used in determining the best route. Lower router preference values are preferred over higher router preference values.

Format	show ip route preferences
Modes	Privileged EXECUser EXEC
Local	This field displays the local route preference value.
Static	This field displays the static route preference value.
OSPF Intra	This field displays the OSPF Intra route preference value.
OSPF Inter	This field displays the OSPF Inter route preference value.
OSPF Type-1	This field displays the OSPF Type-1 route preference value.
OSPF Type-2	This field displays the OSPF Type-2 route preference value.
RIP	This field displays the RIP route preference value.
BGP4	This field displays the BGP-4 route preference value.

11.2.17 show ip stats

This command displays IP statistical information. Refer to RFC 1213 for more information about the fields that are displayed. This command takes no options.

Format	show ip stats
Modes	Privileged EXECUser EXEC

11.2.18 encapsulation

This command configures the link layer encapsulation type for the packet. Acceptable values for <encapstype> are Ethernet and SNAP. The default is Ethernet.

Format	encapsulation {ethernet snap}
Mode	Interface Config
Restrictions	Routed frames are always Ethernet encapsulated when a frame is routed to a VLAN.

11.3 Router Discovery Protocol Commands

This chapter provides a detailed explanation of the Router Discovery commands. The commands are divided by functionality into the following different groups:

- Show commands are used to display switch settings, statistics and other information.
- Configuration Commands are used to configure features and options of the switch. For every configuration command there is a show command that will display the configuration setting.
- Copy commands are used to transfer configuration and informational files to and from the switch.

11.3.1 *ip irdp*

This command enables Router Discovery on an interface.

Default	disabled
Format	ip irdp
Mode	Interface Config

11.3.1.1 *no ip irdp*

This command disables Router Discovery on an interface.

Format	no ip irdp
Mode	Interface Config

11.3.2 *ip irdp address*

This command configures the address to be used to advertise the router for the interface. The valid values for ipaddr are 224.0.0.1 and 255.255.255.255.

Default	224.0.0.1
Format	ip irdp address <ipaddr>
Mode	Interface Config

11.3.2.1 *no ip irdp address*

This command configures the default address to be used to advertise the router for the interface.

Format	no ip irdp address
Mode	Interface Config

11.3.3 *ip irdp holdtime*

This command configures the value, in seconds, of the holdtime field of the router advertisement sent from this interface. The range is the maxadvertinterval to 9000 seconds.

Default	3 * maxinterval
Format	ip irdp holdtime <maxadvertinterval-9000>
Mode	Interface Config

11.3.3.1 *no ip irdp holdtime*

This command configures the default value, in seconds, of the holdtime field of the router advertisement sent from this interface.

Format no ip irdp holdtime
Mode Interface Config

11.3.4 ip irdp maxadvertinterval

This command configures the maximum time, in seconds, allowed between sending router advertisements from the interface. The range for maxadvertinterval is 4 to 1800 seconds.

Default 600
Format ip irdp maxadvertinterval <4-1800>
Mode Interface Config

11.3.4.1 no ip irdp maxadvertinterval

This command configures the default maximum time, in seconds.

Format no ip irdp maxadvertinterval
Mode Interface Config

11.3.5 ip irdp minadvertinterval

This command configures the minimum time, in seconds, allowed between sending router advertisements from the interface. The range for minadvertinterval is 3 to the value of maxadvertinterval.

Default 0.75 * maxadvertinterval
Format ip irdp minadvertinterval <3-maxadvertinterval>
Mode Interface Config

11.3.5.1 no ip irdp minadvertinterval

This command configures the default minimum time, in seconds.

Format no ip irdp minadvertinterval
Mode Interface Config

11.3.6 ip irdp preference

This command configures the preferability of the address as a default router address, relative to other router addresses on the same subnet. The range is -2147483648 to -1 to 0 to 1 to 2147483647.

Default 0
Format ip irdp preference <-2147483648-2147483647>
Mode Interface Config

11.3.6.1 no ip irdp preference

This command configures the default preferability of the address as a default router address, relative to other router addresses on the same subnet.

Format no ip irdp preference
Mode Interface Config

11.3.7 *show ip irdp*

This command displays the router discovery information for all interfaces, or a specified interface.

Format **show ip irdp {<unit/slot/port> / all}**
Modes **Privileged EXEC User EXEC**

Ad Mode Displays the advertise mode which indicates whether router discovery is enabled or disabled on this interface.

Max Int Displays the maximum advertise interval which is the maximum time allowed between sending router advertisements from the interface in seconds.

Min Int Displays the minimum advertise interval which is the minimum time allowed between sending router advertisements from the interface in seconds.

Adv LifeDisplays advertise lifetime which is the value of the lifetime field of the router advertisement sent from the interface in seconds.

Preferences Displays the preference of the address as a default router address, relative to other router addresses on the same subnet.

11.4 Virtual LAN Routing Commands

This chapter provides a detailed explanation of the Virtual LAN Routing commands. The commands are divided by functionality into the following different groups:

- Show commands are used to display switch settings, statistics and other information.
- Configuration Commands are used to configure features and options of the switch. For every configuration command there is a show command that will display the configuration setting.
- Copy commands are used to transfer configuration and informational files to and from the switch.

11.4.1 *vlan routing*

This command creates routing on a VLAN. The <vlanid> value has a range from 1 to 4094.

Format `vlan routing <vlanid>`

Mode `VLAN Database`

11.4.1.1 *no vlan routing*

This command deletes routing on a VLAN. The <vlanid> value has a range from 1 to 4094.

Format `no vlan routing <vlanid>`

Mode `VLAN Database`

11.4.2 *show ip vlan*

This command displays the VLAN routing information for all VLANs with routing enabled in the system.

Format `show ip vlan`

Modes `Privileged EXEC User EXEC`

MAC Address used by Routing VLANs Is the MAC Address associated with the internal bridge-router interface (IBRI). The same MAC Address is used by all VLAN routing interfaces. It will be displayed above the per-VLAN information.

VLAN ID Is the identifier of the VLAN.

Logical Interface Indicates the logical unit/slot/port associated with the VLAN routing interface.

IP Address Displays the IP Address associated with this VLAN.

Subnet Mask Indicates the subnet mask that is associated with this VLAN.

11.5 Virtual Router Redundancy Protocol (VRRP) Commands

This chapter provides a detailed explanation of the VRRP commands. The commands are divided by functionality into the following different groups:

- Show commands are used to display switch settings, statistics and other information.
- Configuration Commands are used to configure features and options of the switch. For every configuration command there is a show command that will display the configuration setting.
- Copy commands are used to transfer configuration and informational files to and from the switch.

11.5.1 *ip vrrp*

This command sets the virtual router ID on an interface for Virtual Router configuration in the router. This command also designates the configured virtual router IP address as a secondary IP address on an interface. The parameter <vrID> is the virtual router ID which has an integer value range from 1 to 255.

Default none

Format `ip vrrp <vrID> <ipaddress> [secondary]`

Mode Interface Config

11.5.1.1 *no ip vrrp*

This command removes all VRRP configuration details of the virtual router configured on a specific interface. This command also removes a virtual router IP address as a secondary IP address on an interface. The parameter <vrID> is the virtual router ID which has an integer value ranges from 1 to 255.

Format `no ip vrrp <vrID> <ipaddress> [secondary]`

Mode Interface Config

11.5.2 *ip vrrp*

This command enables the administrative mode of VRRP in the router. This command also designates the configured virtual router IP address as a secondary IP address on an interface.

Default enabled

Format `ip vrrp <vrid> <ipaddress> [secondary]`

Mode Global Config

11.5.2.1 *no ip vrrp*

This command disables the default administrative mode of VRRP in the router.

Format no ip vrrp

Mode Global Config

11.5.3 ip vrrp mode

This command enables the virtual router configured on the specified interface. Enabling the status field starts a virtual router. The parameter <vrID> is the virtual router ID which has an integer value ranging from 1 to 255.

Default disabled

Format ip vrrp <vrID> mode

Mode Interface Config

11.5.3.1 no ip vrrp mode

This command disables the virtual router configured on the specified interface. Disabling the status field stops a virtual router.

Format no ip vrrp <vrID> mode

Mode Interface Config

11.5.4 ip vrrp ip

This command sets the ipaddress value for a virtual router. The value for <ipaddr> is the IP Address which is to be configured on that interface for VRRP. The parameter <vrID> is the virtual router ID which has an integer value range from 1 to 255.

Default none

Format ip vrrp <vrID> ip <ipaddr>

Mode Interface Config

11.5.5 ip vrrp authentication

This command sets the authorization details value for the virtual router configured on a specified interface. The parameter {none | simple} specifies the authorization type for virtual router configured on the specified interface. The parameter [key] is optional, it is only required when authorization type is simple text password. The parameter <vrID> is the virtual router ID which has an integer value ranges from 1 to 255.

Default no authorization

Format ip vrrp <vrID> authentication {none / simple <key>}

Mode Interface Config

11.5.5.1 *no ip vrrp authentication*

This command sets the default authorization details value for the virtual router configured on a specified interface.

Format **no ip vrrp <vrID> authentication**

Mode **Interface Config**

11.5.6 *ip vrrp preempt*

This command sets the preemption mode value for the virtual router configured on a specified interface. The parameter <vrID> is the virtual router ID which has an integer value range from 1 to 255.

Default enabled

Format **ip vrrp <vrID> preempt**

Mode **Interface Config**

11.5.6.1 *no ip vrrp preempt*

This command sets the default preemption mode value for the virtual router configured on a specified interface.

Format **no ip vrrp <vrID> preempt**

Mode **Interface Config**

11.5.7 *ip vrrp priority*

This command sets the priority value for the virtual router configured on a specified interface. The priority of the interface is a priority integer from 1 to 254. The parameter <vrID> is the virtual router ID which has an integer value ranges from 1 to 255.

Default 100

Format **ip vrrp <vrID> priority <1-254>**

Mode **Interface Config**

11.5.7.1 *no ip vrrp priority*

This command sets the default priority value for the virtual router configured on a specified interface.

Format **no ip vrrp <vrID> priority**

Mode **Interface Config**

11.5.8 ip vrrp timers advertise

This command sets the advertisement value for a virtual router. The value for advinterval is time used for VRRP advertisement in seconds. The parameter <vrID> is the virtual router ID which has an integer

value range from 1 to 255.

Default 1

Format ip vrrp <vrID> timers advertise <1-255>

Mode Interface Config

11.5.8.1 no ip vrrp timers advertise

This command sets the default advertisement value for a virtual router.

Format no ip vrrp <vrID> timers advertise

Mode Interface Config

11.5.9 show ip vrrp interface stats

This command displays the statistical information about each virtual router configured on the switch.

Format show ip vrrp interface stats <unit/slot/port> <vrID>

Modes Privileged EXEC User EXEC

Uptime Is the time that the virtual router has been up, in days, hours, minutes and seconds.

Protocol Represents the protocol configured on the interface.

State Transitioned to Master Represents the total number of times virtual router state has changed to MASTER.

Advertisement Received Represents the total number of VRRP advertisements received by this virtual router.

Advertisement Interval Errors Represents the total number of VRRP advertisements received for which advertisement interval is different than the configured value for this virtual router.

Authentication Failure Represents the total number of VRRP packets received that don't pass the authentication check.

IP TTL errors Represents the total number of VRRP packets received by the virtual router with IP TTL (time to live) not equal to 255.

Zero Priority Packets Received Represents the total number of VRRP packets received by virtual router with a priority of '0'.

Zero Priority Packets Sent Represents the total number of VRRP packets sent by the virtual router with a priority of '0'.

Invalid Type Packets Received Represents the total number of VRRP packets received by the virtual router with invalid 'type' field.

Address List Errors Represents the total number of VRRP packets received for which address list does not match the locally configured list for the virtual router.

Invalid Authentication Type Represents the total number of VRRP packets received with unknown authentication type.

Authentication Type Mismatch Represents the total number of VRRP advertisements received for which 'auth type' not equal to locally configured one for this virtual router.

Packet Length Errors Represents the total number of VRRP packets received with packet length less than length of VRRP header

11.5.10 show ip vrrp

This command displays whether VRRP functionality is enabled or disabled on the switch. It also displays some global parameters which are required for monitoring This command takes no options.

Format show ip vrrp

Modes Privileged EXEC User EXEC

VRRP Admin Mode Displays the administrative mode for VRRP functionality on the switch.

Router Checksum Errors Represents the total number of VRRP packets received with an invalid VRRP checksum value.

Router Version Errors Represents the total number of VRRP packets received with Unknown or unsupported version number.

Router VRID Errors Represents the total number of VRRP packets received with invalid VRID for this virtual router.

11.5.11 show ip vrrp interface

This command displays all configuration information and VRRP router statistics of a virtual router configured on a specific interface.

Format show ip vrrp interface <unit/slot/port> <vrID>

Modes Privileged EXEC User EXEC

IP Address This field represents the configured IP Address for the Virtual router.

VMAC address Represents the VMAC address of the specified router.

Authentication type Represents the authentication type for the specific virtual router.

Priority Represents the priority value for the specific virtual router.

Advertisement interval Represents the advertisement interval for the specific virtual router.

Pre-Empt Mode Is the preemption mode configured on the specified virtual router.

Administrative Mode Represents the status (Enable or Disable) of the specific router.

State Represents the state (Master/backup) of the specific virtual

11.5.12 show ip vrrp interface brief

This command displays information about each virtual router configured on the switch. This

command takes no options. It displays information about each virtual router.

Format `show ip vrrp interface brief`

Modes Privileged EXEC User EXEC

Unit/Slot/Port Valid unit, slot and port number separated by forward slashes.

VRID Represents the router ID of the virtual router.

IP Address Is the IP Address that was configured on the virtual router

Mode Represents whether the virtual router is enabled or disabled.

State Represents the state (Master/backup) of the virtual router.

11.6 Open Shortest Path First (OSPF) Commands

This chapter provides a detailed explanation of the OSPF commands. The commands are divided by functionality into the following different groups:

- Show commands are used to display switch settings, statistics and other information. □
- Configuration Commands are used to configure features and options of the switch. For every configuration command there is a show command that will display the configuration setting. □
- Copy commands are used to transfer configuration and informational files to and from the switch.

11.6.1 *enable (OSPF)*

This command resets the default administrative mode of OSPF in the router (active).

Default enabled

Format enable

Mode Router OSPF Config

11.6.1.1 *no enable (OSPF)*

This command sets the administrative mode of OSPF in the router to inactive.

Format no enable

Mode Router OSPF Config

11.6.2 *ip ospf*

This command enables OSPF on a router interface.

Default disabled

Format ip ospf

Mode Interface Config

11.6.2.1 *no ip ospf*

This command disables OSPF on a router interface.

Format no ip ospf

Mode Interface Config

11.6.3 *1583compatibility*

This command enables OSPF 1583 compatibility.

Note: 1583 compatibility mode is enabled by default. If all OSPF routers in the routing domain are capable of operating according to RFC 2328, OSPF 1583 compatibility mode should be disabled.

Default enabled

Format 1583compatibility

Mode Router OSPF Config

11.6.3.1 no 1583compatibility

This command disables OSPF 1583 compatibility.

Format no 1583compatibility

Mode Router OSPF Config

11.6.4 area authentication

This command specifies the authentication type to be used for the specified area id.

Default none

Format area <areaid> authentication {none | simple | encrypt}

Mode Router OSPF Config

11.6.4.1 no area authentication

This command sets the default authentication type to be used for the specified area id.

Format no area <areaid> authentication

Mode Router OSPF Config

11.6.5 area default-cost

This command configures the monetary default cost for the stub area. The operator must specify the area id and an integer value between 1-16777215.

Format area <areaid> default-cost <1-16777215>

Mode Router OSPF Config

11.6.6 area nssa

This command configures the specified areaid to function as an NSSA.

Format area <areaid> nssa

Mode Router OSPF Config

11.6.6.1 no area nssa

This command disables nssa from the specified area id.

Format no area <areaid> nssa

Mode Router OSPF Config

11.6.7 area nssa default-info-originate

This command configures the metric value and type for the default route advertised into the NSSA. The optional metric parameter specifies the metric of the default route and is to be in a range of 1-16777215. If no metric is specified, the default value is ****. The metric type can be comparable (nssa-external 1) or non-comparable (nssa-external 2).

Format area <areaid> nssa default-info-originate [<metric>] [{comparable non-comparable}]

Mode Router OSPF Config

11.6.8 area nssa no-redistribute (OSPF)

This command configures the NSSA ABR so that learned external routes will not be redistributed to the NSSA.

Format area <areaid> nssa no-redistribute

Mode Router OSPF Config

11.6.9 area nssa no-summary (OSPF)

This command configures the NSSA so that summary LSAs are not advertised into the NSSA

Format area <areaid> nssa no-summary

Mode Router OSPF Config

11.6.10 area nssa translator-role (OSPF)

This command configures the translator role of the NSSA. A value of *always* will cause the router to assume the role of the translator the instant it becomes a border router and a value of *candidate* will cause the router to participate in the translator election process when it attains border router status

Format area <areaid> nssa translator-role {always | candidate}

Mode Router OSPF Config

11.6.11 area nssa translator-stab-intv

This command configures the translator stability interval of the NSSA. The *stabilityinterval* is the period of time that an elected translator continues to perform its duties after it determines that its translator status has been deposed by another router.

Format area <areaid> nssa translator-stab-intv <stabilityinterval>

Mode Router OSPF Config

11.6.12 area range

This command creates a specified area range for a specified NSSA. The <ipaddr> is a valid IP address. The <subnetmask> is a valid subnet mask. The *lsdb* type must be specified by either *summarylink* or *nssaexternallink*, and the advertising of the area range can be optionally allowed or suppressed.

Format area <areaid> range <ipaddr> <subnetmask> {summarylink | nssaexternallink} [advertise | not-advertise]

Mode Router OSPF Config

11.6.12.1 no area range

This command deletes a specified area range. The <ipaddr> is a valid IP address. The <subnetmask> is a valid subnet mask.

Format no area <areaid> range <ipaddr> <subnetmask>

Mode Router OSPF Config

11.6.13 area stub

This command creates a stub area for the specified area ID. A stub area is characterized by the fact that AS External LSAs are not propagated into the area. Removing AS External LSAs and Summary LSAs can significantly reduce the link state database of routers within the stub area.

Format area <areaid> stub

Mode Router OSPF Config

11.6.13.1 no area stub

This command deletes a stub area for the specified area ID.

Format no area <areaid> stub

Mode Router OSPF Config

11.6.14 *area stub summarylsa*

This command configures the Summary LSA mode for the stub area identified by **<areaid>**. The Summary LSA mode is configured as enabled.

Default disabled

Format area **<areaid>** stub summarylsa

Mode Router OSPF Config

11.6.14.1 *no area stub summarylsa*

This command configures the default Summary LSA mode for the stub area identified by **<areaid>**.

Format no area **<areaid>** stub summarylsa

Mode Router OSPF Config

11.6.15 *area virtual-link*

This command creates the OSPF virtual interface for the specified **<areaid>** and **<neighbor>**. The **<neighbor>** parameter is the Router ID of the neighbor.

Format area **<areaid>** virtual-link **<neighbor>**

Mode Router OSPF Config

11.6.15.1 *no area virtual-link*

This command deletes the OSPF virtual interface from the given interface, identified by **<areaid>** and **<neighbor>**. The **<neighbor>** parameter is the Router ID of the neighbor.

Format no area **<areaid>** virtual-link **<neighbor>**

Mode Router OSPF Config

11.6.16 *area virtual-link authentication*

This command configures the authentication type and key for the OSPF virtual interface identified by **<areaid>** and **<neighbor>**. The **<neighbor>** parameter is the Router ID of the neighbor. The value for **<type>** is either none, simple, or encrypt. The **[key]** is composed of standard displayable, non-control keystrokes from a Standard 101/102-key keyboard. The authentication key must be 8 bytes or less if the authentication type is simple. If the type is encrypt, the key may be up to 256 bytes. Unauthenticated interfaces do not need an authentication key. If the type is encrypt, a key id in the range of 0 and 255 must be specified. The default value for authentication type is none.

Neither the default password key nor the default key id are configured.

Default none

Format area <areaid> virtual-link <neighbor> authentication {none | {simple <key>} |
{encrypt <key> <keyid>}}

Mode Router OSPF Config

11.6.16.1 no area virtual-link authentication

This command configures the default authentication type for the OSPF virtual interface identified by <areaid> and <neighbor>. The <neighbor> parameter is the Router ID of the neighbor.

Format no area <areaid> virtual-link <neighbor> authentication 3

Mode Router OSPF Config

11.6.17 area virtual-link dead-interval

This command configures the dead interval for the OSPF virtual interface on the virtual interface identified by <areaid> and <neighbor>. The <neighbor> parameter is the Router ID of the neighbor. The range for <seconds> is 1 to 65535.

Default 40

Format area <areaid> virtual-link <neighbor> dead-interval <1-65535>

Mode Router OSPF Config

11.6.17.1 no area virtual-link dead-interval

This command configures the default dead interval for the OSPF virtual interface on the virtual interface identified by <areaid> and <neighbor>. The <neighbor> parameter is the Router ID of the neighbor.

Format no area <areaid> virtual-link <neighbor> dead-interval

Mode Router OSPF Config

11.6.18 area virtual-link hello-interval

This command configures the hello interval for the OSPF virtual interface on the virtual interface identified by <areaid> and <neighbor>. The <neighbor> parameter is the Router ID of the neighbor. The range for <seconds> is 1 to 65535.

Default 10

Format area <areaid> virtual-link <neighbor> hello-interval <1-65535>

Mode Router OSPF Config

11.6.18.1 no area virtual-link hello-interval

This command configures the default hello interval for the OSPF virtual interface on the virtual interface identified by **<areaid>** and **<neighbor>**. The **<neighbor>** parameter is the Router ID of the neighbor.

Format no area **<areaid>** virtual-link **<neighbor>** hello-interval

Mode Router OSPF Config

11.6.19 area virtual-link retransmit-interval

This command configures the retransmit interval for the OSPF virtual interface on the virtual interface identified by **<areaid>** and **<neighbor>**. The **<neighbor>** parameter is the Router ID of the neighbor. The range for **<seconds>** is 0 to 3600.

Default 5

Format area **<areaid>** virtual-link **<neighbor>** retransmit-interval **<0-3600>**

Mode Router OSPF Config

11.6.19.1 no area virtual-link retransmit-interval

This command configures the default retransmit interval for the OSPF virtual interface on the virtual interface identified by **<areaid>** and **<neighbor>**. The **<neighbor>** parameter is the Router ID of the neighbor.

Format no area **<areaid>** virtual-link **<neighbor>** retransmit-interval

Mode Router OSPF Config

11.6.20 area virtual-link transmit-delay

This command configures the transmit delay for the OSPF virtual interface on the virtual interface identified by **<areaid>** and **<neighbor>**. The **<neighbor>** parameter is the Router ID of the neighbor. The range for **<seconds>** is 0 to 3600 (1 hour).

Default 1

Format area **<areaid>** virtual-link **<neighbor>** transmit-delay **<0-3600>**

Mode Router OSPF Config

11.6.20.1 no area virtual-link transmit-delay

This command configures the default transmit delay for the OSPF virtual interface on the virtual interface identified by **<areaid>** and **<neighbor>**. The **<neighbor>** parameter is the Router ID of the neighbor.

Format no area **<areaid>** virtual-link **<neighbor>** transmit-delay

Mode Router OSPF Config

11.6.21 *default-information originate (OSPF)*

This command is used to control the advertisement of default routes.

Default metric -- unspecified; type – 2

Format **default-information originate [always] [metric <0-16777215>]**
[metric-type {1 | 2}]

Mode Router OSPF Config

11.6.21.1 *no default-information originate (OSPF)*

This command is used to control the advertisement of default routes.

Format **no default-information originate [metric] [metric-type]**

Mode Router OSPF Config

11.6.22 *default-metric (OSPF)*

This command is used to set a default for the metric of distributed routes.

Format **default-metric <1-16777215>**

Mode Router OSPF Config

11.6.22.1 *no default-metric (OSPF)*

This command is used to set a default for the metric of distributed routes.

Format **no default-metric**

Mode Router OSPF Config

11.6.23 *distance ospf*

This command sets the route preference value of OSPF in the router. Lower route preference values are preferred when determining the best route. The type of OSPF can be intra, inter, type-1, or type-2. The OSPF specification (RFC 2328) requires that preferences must be given to the routes learned via OSPF in the following order: intra < inter < type-1 < type-2.

The range of preference is 0 to 255.

Default intra -- 8; inter -- 10; type-1 -- 13; type-2 --150.

Format **disatance ospf {intra | inter | type1 | type2} <0-255>**

Mode Router OSPF Config

11.6.23.1 *no distance ospf*

This command sets the default route preference value of OSPF in the router. The type of OSPF can be intra, inter, type-1, or type-2. Format

Format no disatance ospf {intra | inter | type1 | type2}

Mode Router OSPF Config

11.6.24 distribute-list out

This command is used to specify the access list to filter routes received from the source protocol.

Format distribute-list <1-199> out {rip | bgp | static | connected}

Mode Router OSPF Config

11.6.24.1 no distribute-list out

This command is used to specify the access list to filter routes received from the source protocol.

Format no distribute-list <1-199> out {rip | bgp | static | connected}

Mode Router OSPF Config

11.6.25 exit-overflow-interval

This command configures the exit overflow interval for OSPF. It describes the number of seconds after entering Overflow state that a router will wait before attempting to leave the Overflow State. This allows the router to again originate non-default AS-external-LSAs. When set to 0, the router will not leave Overflow State until restarted. The range for <seconds> is 0 to 2147483647 seconds.

Default 0

Format exit-overflow-interval <0-2147483647>

Mode Router OSPF Config

11.6.25.1 no exit-overflow-interval

This command configures the default exit overflow interval for OSPF.

Format no exit-overflow-interval

Mode Router OSPF Config

11.6.26 external-lsdb-limit

This command configures the external LSDB limit for OSPF. If the value is -1, then there is no limit. When the number of non-default AS-external-LSAs in a router's link-state database reaches the external LSDB limit, the router enters overflow state. The router never holds more than the external LSDB limit non-default AS-external-LSAs in it database. The external LSDB limit MUST be set identically in all routers attached to the OSPF backbone and/or any regular OSPF area. The range for <limit> is -1 to 2147483647.

Default -1

Format external-lsdb-limit <-1-2147483647>

Mode Router OSPF Config

11.6.26.1 *no external-lsdb-limit*

This command configures the default external LSDB limit for OSPF.

Format `no external-lsdb-limit`

Mode Router OSPF Config

11.6.27 *ip ospf areaid*

This command sets the OSPF area to which the specified router interface belongs. The value for <areaid> is an IP address, formatted as a 4-digit dotted-decimal number that uniquely identifies the area to which the interface connects. Assigning an area id, which does not exist on an interface, causes the area to be created with default values.

Format `ip ospf areaid <areaid>`

Mode Interface Config

11.6.28 *ip ospf authentication*

This command sets the OSPF Authentication Type and Key for the specified interface.

The value of <type> is either none, simple or encrypt. The [key] is composed of standard displayable, non-control keystrokes from a Standard 101/102-key keyboard. The authentication key must be 8 bytes or less if the authentication type is simple. If the type is encrypt, the key may be up to 256 bytes. If the type is encrypt a <keyid> in the range of 0 and 255 must be specified.

Default The default authentication type is none.

Default The default password key is not configured. Unauthenticated interfaces do not need an authentication key.

Default The default keyid is not configured. Unauthenticated interfaces do not need an authentication key id.

Format `ip ospf authentication {none | {simple <key>} | {encrypt <key> <keyid>}}`

Mode Interface Config

11.6.28.1 *no ip ospf authentication*

This command sets the default OSPF Authentication Type for the specified interface.

Format `no ip ospf authentication`

Mode Interface Config

11.6.29 *ip ospf cost*

This command configures the cost on an OSPF interface. The <cost> parameter has a range of 1 to 65535.

Default 10

Format ip ospf cost <1-5535>

Mode Interface Config

11.6.29.1 no ip ospf cost

This command configures the default cost on an OSPF interface. The <cost> parameter has a range of 1 to 65535.

Format no ip ospf cost

Mode Interface Config

11.6.30 ip ospf dead-interval

This command sets the OSPF dead interval for the specified interface.

The value for <seconds> is a valid positive integer, which represents the length of time in seconds that a router's Hello packets have not been seen before its neighbor routers declare that the router is down. The value for the length of time must be the same for all routers attached to a common network. This value should be some multiple of the Hello Interval (i.e. 4).

Valid values range for <seconds> is from 1 to 2147483647.

Default 40

Format ip ospf dead-interval <1-2147483647>

Mode Interface Config

11.6.30.1 no ip ospf dead-interval

This command sets the default OSPF dead interval for the specified interface.

Format no ip ospf dead-interval

Mode Interface Config

11.6.31 ip ospf hello-interval

This command sets the OSPF hello interval for the specified interface.

The value for <seconds> is a valid positive integer, which represents the length of time in seconds. The value for the length of time must be the same for all routers attached to a network.

Valid values range from 1 to 65535.

Default 10

Format ip ospf hello-interval <1-65535>

Mode Interface Config

11.6.31.1 no ip ospf hello-interval

This command sets the default OSPF hello interval for the specified interface.

Format no ip ospf hello-interval

Mode Interface Config

11.6.32 ip ospf priority

This command sets the OSPF priority for the specified router interface. The priority of the interface is a priority integer from 0 to 255.

A value of '0' indicates that the router is not eligible to become the designated router on this network.

Default , which is the highest router priority.

Format ip ospf priority <0-255>

Mode Interface Config

11.6.32.1 no ip ospf priority

This command sets the default OSPF priority for the specified router interface.

Format no ip ospf priority

Mode nterface Config

11.6.33 ip ospf retransmit-interval

This command sets the OSPF retransmit Interval for the specified interface. The retransmit interval is specified in seconds.

The value for <seconds> is the number of seconds between link-state advertisement retransmissions for adjacencies belonging to this router interface. This value is also used when retransmitting database description and link-state request packets.

Valid values range from 0 to 3600 (1 hour).

Default 5

Format ip ospf retransmit-interval <0-3600>

Mode Interface Config

11.6.33.1 no ip ospf retransmit-interval

This command sets the default OSPF retransmit Interval for the specified interface.

Format no ip ospf retransmit-interval

Mode Interface Config

11.6.34 ip ospf transmit-delay

This command sets the OSPF Transit Delay for the specified interface. The transmit delay is specified in seconds. In addition, it sets the estimated number of seconds it takes to transmit a link state update packet over this interface.

Valid values for <seconds> range from 1 to 3600 (1 hour).

Default 1

Format ip ospf transmit-delay <1-3600>

Mode Interface Config

11.6.34.1 no ip ospf transmit-delay

This command sets the default OSPF Transit Delay for the specified interface.

Format no ip ospf transmit-delay

Mode Interface Config

11.6.35 ip ospf mtu-ignore

This command disables OSPF maximum transmission unit (MTU) mismatch detection. OSPF Database Description packets specify the size of the largest IP packet that can be sent without fragmentation on the interface. When a router receives a Database Description packet, it examines the MTU advertised by the neighbor. By default, if the MTU is larger than the router can accept, the Database Description packet is rejected and the OSPF adjacency is not established.

Default Enabled

Format ip ospf mtu-ignore

Mode Interface Config

11.6.35.1 no ip ospf mtu-ignore

This command enables the OSPF MTU mismatch detection.

Format no ip ospf mtu-ignore

Mode Interface Config

11.6.36 router-id

This command sets a 4-digit dotted-decimal number uniquely identifying the router ospf id. The <ipaddress> is a configured value.

Format router-id <ipaddress>

Mode Router OSPF Config

11.6.37 redistribute

This command configures OSPF protocol to redistribute routes from the specified source protocol/ routers.

Default metric -- unspecified; type -- 2; tag – 0

Format redistribute {rip | bgp | static | connected} [metric <0-16777215>] [metric-type {1 | 2}] [tag <0-4294967295>] [subnets

Mode Router OSPF Config

11.6.37.1 no redistribute

This command configures OSPF protocol to redistribute routes from the specified source protocol/ routers.

Format no redistribute {rip | bgp | static | connected} [metric] [metric-type] [tag] [subnets]

Mode Router OSPF Config

11.6.38 maximum-paths

This command sets the number of paths that OSPF can report for a given destination where maxpaths is platform dependent.

Default 4

Format maximum-paths <maxpaths>

Mode OSPF Router Config

11.6.38.1 no maximum-paths

This command resets the number of paths that OSPF can report for a given destination back to its default value.

Format no maximum-paths

Mode OSPF Router Config

11.6.39 show ip ospf

This command displays information relevant to the OSPF router. This command takes no options.

Format show ip ospf

Mode Privileged EXEC

Router ID Is a 32 bit integer in dotted decimal format identifying the router, about which information is displayed. This is a configured value.

OSPF Admin Mode The administrative mode of OSPF in the router. This is a configured value.

ASBR Mode Reflects whether the ASBR mode is enabled or disabled. Enable implies that the router is an autonomous system border router. Router automatically becomes an ASBR when it is configured to redistribute routes learnt from other protocol. The possible values for the ASBR status is enabled (if the router is configured to re-distribute routes learnt by other protocols) or disabled (if the router is not configured for the same).

RFC 1583 Compatibility Reflects whether 1583 compatibility is enabled or disabled. This is a configured value.

Default-metric RDefault value for redistributed routes.

Source Source protocol/routes that are being redistributed.

Metric-value Metric of the routes being redistributed.

Type-value External Type 1 or External Type 2 routes.

Tag-value Decimal value attached to each external route.

Subnets For redistributing routes into OSPF, the scope of redistribution for the specified protocol.

Distribute-list TAccess list used to filter redistributed routes.

Default-info originate Indicates whether the default routes received from other source protocols are advertised or not

The information below will only be displayed if OSPF is enabled.

ABR Status Reflects the whether or not the router is an OSPF Area Border Router.

Exit Overflow Interval The number of seconds that, after entering OverflowState, a router will attempt to leave OverflowState.

External LSA count The number of external (LS type 5) link-state advertisements in the link-state database.

External LSA Checksum A number which represents the sum of the LS checksums of external link-state advertisements contained in the link-state database.

New LSAs Originated The number of new link-state advertisements that have been originated.

LSAs Received The number of link-state advertisements received determined to be new instantiations.

External LSDB Limit The maximum number of non-default AS-external-LSAs entries that can be stored in the link-state database.

Max Paths Maximum number of paths that OSPF can report for a given destination.

11.6.40 *show ip ospf area*

This command displays information about the area. The <areaid> identifies the OSPF area that is being displayed.

Format *show ip ospf area <areaid>*

Modes Privileged EXEC>User EXEC

AreaID Is the area id of the requested OSPF area.

Aging Interval Is a number representing the aging interval for this area.

External Routing Is a number representing the external routing capabilities for this area.

Authentication Type Is the configured authentication type to use for this area.

Spf Runs Is the number of times that the intra-area route table has been calculated using this area's link-state database.

Area Border Router Count The total number of area border routers reachable within this area.

Area LSA Count Total number of link-state advertisements in this area's link-state database, excluding AS External LSA's.

Area LSA Checksum A number representing the Area LSA Checksum for the specified AreaID excluding the external (LS type 5) link-state advertisements.

Stub Mode Represents whether the specified Area is a stub area or not. The possible values are enabled and disabled. This is a configured value.

Import Summary LSAs

Metric Value Is a number representing the Metric Value for the specified area.

Metric Type Is the Default Metric Type for the specified Area.

11.6.41 *show ip ospf database*

This command displays the link state database. This command takes no options.

Note: The information below is only displayed if OSPF is enabled.

Note: The OSPF database information is grouped into sections by link-type and area. The groups are as follows:

- Router Link States□
- Network Link States□
- Network Summary States□
- Summary ASBR States

The AS-Externals are not grouped by area.

Format `show ip ospf database`

Modes **Privileged EXEC** **User EXEC**

For each link-type and area, the following information is displayed.

Link Id Is a number that "uniquely identifies an LSA that a router originates from all other self originated LSA's of the same LS type.

Adv Router The Advertising Router. Is a 32 bit dotted decimal number representing the LSDB interface.

Age Is a number representing the age of the link state advertisement in seconds.

Sequence Is a number that represents which LSA is more recent.

Checksum Is the total number LSA checksum.

Options This is an integer. It indicates that the LSA receives special handling during routing calculations.

Rtr Opt Router Options are valid for router links only.

11.6.42 show ip ospf interface

This command displays the information for the IFO object or virtual interface tables.

Format `show ip ospf interface <unit/slot/port>`

Modes **Privileged EXEC** **User EXEC**

IP Address Represents the IP address for the specified interface. This is a configured value.

Subnet Mask Is a mask of the network and host portion of the IP address for the OSPF interface. This value was configured into the unit. This is a configured value.

OSPF Admin Mode States whether OSPF is enabled or disabled on a router interface. This is a configured value.

OSPF Area ID Represents the OSPF Area Id for the specified interface. This is a configured value.

Router Priority A number representing the OSPF Priority for the specified interface. This is a configured value.

Retransmit Interval A number representing the OSPF Retransmit Interval for the specified interface. This is a configured value.

Hello Interval A number representing the OSPF Hello Interval for the specified interface. This is a configured value.

Dead Interval A number representing the OSPF Dead Interval for the specified interface. This

is a configured value.

LSA Ack Interval A number representing the OSPF LSA Acknowledgement Interval for the specified interface.

Transit Delay Interval A number representing the OSPF Transit Delay for the specified interface. This is a configured value.

Authentication Type The OSPF Authentication Type for the specified interface are: none, simple, and encrypt. This is a configured value.

The information below will only be displayed if OSPF is enabled.

OSPF Interface Type Broadcast LANs, such as Ethernet and IEEE 802.5, take the value 'broadcast'. The OSPF Interface Type will be 'broadcast'.

State The OSPF Interface States are: down, loopback, waiting, point-to-point, designated router, and backup designated router. This is the state of the OSPF interface.

Designated Router Is the router ID representing the designated router.

Backup Designated Router Is the router ID representing the backup designated router.

Number of Link Events The number of link events.

Metric Cost Is the cost of the ospf interface. This is a configured value.

11.6.43 show ip ospf interface brief

This command displays brief information for the IFO object or virtual interface tables. This command takes no options.

Format `show ip ospf interface brief`

Modes `Privileged EXEC User EXEC`

Unit/Slot/Port Valid unit, slot and port number separated by forward slashes.

OSPF Admin Mode States whether OSPF is enabled or disabled on a router interface. This is a configured value.

OSPF Area ID Represents the OSPF Area Id for the specified interface. This is a configured value.

Router Priority A number representing the OSPF Priority for the specified interface. This is a configured value.

Hello Interval A number representing the OSPF Hello Interval for the specified interface. This is a configured value.

Dead Interval A number representing the OSPF Dead Interval for the specified interface. This is a configured value.

Retransmit Interval A number representing the OSPF Retransmit Interval for the specified interface. This is a configured value.

Transit Delay Interval A number representing the OSPF Transit Delay for the specified interface. This is a configured value.

LSA Ack Interval A number representing the OSPF LSA Acknowledgement Interval for the specified interface.

11.6.44 *show ip ospf interface stats*

This command displays the statistics for a specific interface. The information below will only be displayed if OSPF is enabled.

Format `show ip ospf interface stats <unit/slot/port>`

Modes Privileged EXEC User EXEC

OSPF Area ID The area id of this OSPF interface.

Spf Runs The number of times that the intra-area route table has been calculated using this area's link-state database.

Area Border Router Count The total number of area border routers reachable within this area. This is initially zero, and is calculated in each SPF pass.

AS Border Router Count The total number of Autonomous System border routers reachable within this area.

Area LSA Count The total number of link-state advertisements in this area's link-state database, excluding AS External LSAs.

P Address The IP address associated with this OSPF interface.

OSPF Interface Events The number of times the specified OSPF interface has changed its state, or an error has occurred.

Virtual Events The number of state changes or errors that occurred on this virtual link.

Neighbor Events The number of times this neighbor relationship has changed state, or an error has occurred.

External LSA Count The number of external (LS type 5) link-state advertisements in the link-state database.

LSAs Received The number of LSAs received.

Originate New LSAs The number of LSAs originated.

11.6.45 *show ip ospf neighbor*

This command displays the OSPF neighbor table list. When a particular neighbor ID is specified, detailed information about a neighbor is given. The information below will only be displayed if OSPF is enabled and the interface has a neighbor. The IP address is the IP address of the neighbor.

Format `show ip ospf neighbor <ipaddr> <unit/slot/port>`

Modes Privileged EXEC User EXEC

Interface Valid unit, slot and port number separated by forward slashes.

Router Id Is a 4-digit dotted-decimal number identifying neighbor router.

Options An integer value that indicates the optional OSPF capabilities supported by the neighbor. The neighbor's optional OSPF capabilities are also listed in its Hello packets. This enables received Hello Packets to be rejected (i.e., neighbor relationships will not even start to form) if there is a mismatch in certain crucial OSPF capabilities.

Router Priority Displays the OSPF priority for the specified interface. The priority of an interface is a priority integer from 0 to 255. A value of '0' indicates that the router is not eligible to become the designated router on this network.

State The types are:

Down- initial state of the neighbor conversation - no recent information has been received from the neighbor.

Attempt - no recent information has been received from the neighbor but a more concerted effort should be made to contact the neighbor.

Init - an Hello packet has recently been seen from the neighbor, but bi-directional communication has not yet been established.

2 way - communication between the two routers is bi-directional.

Exchange start - the first step in creating an adjacency between the two neighboring routers, the goal is to decide which router is the master and to decide upon the initial DD sequence number.

Exchange - the router is describing its entire link state database by sending Database Description packets to the neighbor.

Loading - Link State Request packets are sent to the neighbor asking for the more recent LSAs that have been discovered (but not yet received) in the Exchange state.

Full - the neighboring routers are fully adjacent and they will now appear in router-LSAs and network-LSAs.

Events The number of times this neighbor relationship has changed state, or an error has occurred.

Permanence This variable displays the status of the entry, either dynamic or permanent. This refers to how the neighbor became known.

Hellos Suppressed This indicates whether Hellos are being suppressed to the neighbor. The types are enabled and disabled.

Retransmission Queue Length Is an integer representing the current length of the retransmission queue of the specified neighbor router Id of the specified interface.

11.6.46 show ip ospf neighbor brief

This command displays the OSPF neighbor table list. When a particular neighbor ID is specified, detailed information about a neighbor is given. The information below will only be displayed if OSPF is enabled.

Format `show ip ospf neighbor brief {<unit/slot/port> / all}`

Modes Privileged EXEC User EXEC

Router ID A 4 digit dotted decimal number representing the neighbor interface

IP Address An IP address representing the neighbor interface.

Neighbor Interface Index Is a unit/slot/port identifying the neighbor interface index.

11.6.47 show ip ospf range

This command displays information about the area ranges for the specified <areaid>. The <areaid> identifies the OSPF area whose ranges are being displayed.

Format show ip ospf range <areaid>

Modes Privileged EXEC User EXEC

Area ID The area id of the requested OSPF area

IP Address An IP Address which represents this area range

Subnet Mask A valid subnet mask for this area range.

Lsdb Type The type of link advertisement associated with this area range.

Advertisement The status of the advertisement. Advertisement has two possible settings: enabled or disabled.

11.6.48 show ip ospf stub table

This command displays the OSPF stub table. The information below will only be displayed if OSPF is initialized on the switch.

Format show ip ospf stub table

Modes Privileged EXEC User EXEC

Area ID Is a 32-bit identifier for the created stub area.

Type of Service Is the type of service associated with the stub metric. Our switch only supports Normal TOS.

Metric Val The metric value is applied based on the TOS. It defaults to the least metric of the type of service among the interfaces to other areas. The OSPF cost for a route is a function of the metric value.

Metric Type Is the type of metric advertised as the default route.

Import Summary LSA Controls the import of summary LSAs into stub areas.

11.6.49 *show ip ospf virtual-link*

This command displays the OSPF Virtual Interface information for a specific area and neighbor. The <areaid> parameter identifies the area and the <neighbor> parameter identifies the neighbor's Router ID.

Format `show ip ospf virtual-link <areaid> <neighbor>`

Modes Privileged EXEC User EXEC

Area ID The area id of the requested OSPF area.

Neighbor Router ID The input neighbor Router ID.

Hello Interval The configured hello interval for the OSPF virtual interface.

Dead Interval The configured dead interval for the OSPF virtual interface.

Iftransit Delay Interval The configured transit delay for the OSPF virtual interface.

Retransmit Interval The configured retransmit interval for the OSPF virtual interface.

Authentication Type The configured authentication type of the OSPF virtual interface.

State The OSPF Interface States are: down, loopback, waiting, point-to-point, designated router, and backup designated router. This is the state of the OSPF interface.

Neighbor State The neighbor state.

11.6.50 *show ip ospf virtual-link brief*

This command displays the OSPF Virtual Interface information for all areas in the system.

Format `show ip ospf virtual-link brief`

Modes Privileged EXEC User EXEC

Area Id Is the area id of the requested OSPF area.

Neighbor Is the neighbor interface of the OSPF virtual interface.

Hello Interval Is the configured hello interval for the OSPF virtual interface.

Dead Interval Is the configured dead interval for the OSPF virtual interface.

Retransmit Interval Is the configured retransmit interval for the OSPF virtual interface.

Transit Delay Is the configured transit delay for the OSPF virtual interface.

11.6.51 *trapflags*

This command enables OSPF traps.

Default enabled

Format `trapflags`

Mode Router OSPF Config

11.6.51.1 *no trapflags*

This command disables OSPF traps.

Format `no trapflags`

Mode Router OSPF Config

11.7 Routing Information Protocol (RIP) Commands

This chapter provides a detailed explanation of the RIP commands. The commands are divided by functionality into the following different groups:

- Show commands are used to display switch settings, statistics and other information.
- Configuration Commands are used to configure features and options of the switch. For every configuration command there is a show command that will display the configuration setting. □
- Copy commands are used to transfer configuration and informational files to and from the switch.

11.7.1 *enable (RIP)*

This command resets the default administrative mode of RIP in the router (active).

Default enabled

Format enable

Mode Router RIP Config

11.7.1.1 *no enable (RIP)*

This command sets the administrative mode of RIP in the router to inactive.

Format no enable

Mode Router RIP Config

11.7.2 *ip rip*

This command enables RIP on a router interface.

Default disabled

Format ip rip

Mode Interface Config

11.7.2.1 *no ip rip*

This command disables RIP on a router interface.

Format no ip rip

Mode Interface Config

11.7.3 auto-summary

This command enables the RIP auto-summarization mode.

Default disabled

Format auto-summary

Mode Router RIP Config

11.7.3.1 no auto-summary

This command disables the RIP auto-summarization mode.

Format no auto-summary

Mode Router RIP Config

11.7.4 default-information originate (RIP)

This command is used to control the advertisement of default routes.

Format default-information originate

Mode Router RIP Config

11.7.4.1 no default-information originate (RIP)

This command is used to control the advertisement of default routes.

Format no default-information originate

Mode Router RIP Config

11.7.5 default-metric (RIP)

This command is used to set a default for the metric of distributed routes.

Format default-metric <0-15>

Mode Router RIP Config

11.7.5.1 no default-metric (RIP)

This command is used to reset the default metric of distributed routes to its default value.

Format no default-metric

Mode Router RIP Config

11.7.6 distance rip

This command sets the route preference value of RIP in the router. Lower route preference values

are preferred when determining the best route.

Default 15

Format distance rip <0-255>

Mode Router RIP Config

11.7.6.1 no distance rip

This command sets the default route preference value of RIP in the router.

Format no distance rip

Mode Router RIP Config

11.7.7 distribute-list out

This command is used to specify the access list to filter routes received from the source protocol.

Default 0

Format distribute-list <1-199> out {ospf | bgp | static | connected}

Mode Router RIP Config

11.7.7.1 no distribute-list out

This command is used to specify the access list to filter routes received from the source protocol.

Format no distribute-list <1-199> out {ospf | bgp | static | connected}

Mode Router RIP Config

11.7.7.2 no default-information originate

This command is used to control the advertisement of default routes.

Format no default-information originate

Mode Router RIP Config

11.7.8 ip rip authentication

This command sets the RIP Version 2 Authentication Type and Key for the specified interface. The value of <type> is either none, simple, or encrypt.

The value for authentication key [key] must be 16 bytes or less. The [key] is composed of standard displayable, non-control keystrokes from a Standard 101/102-key keyboard. If the value of <type> is encrypt, a keyid in the range of 0 and 255 must be specified.

Default The default authentication type is none.

Default The default password key is an empty string. Unauthenticated interfaces do not need an authentication key.

Default The default key id is not defined. Unauthenticated interfaces do not need an authentication key id.

Format `ip rip authentication {none | {simple <key>} | {encrypt <key><keyid>}}`

Mode Interface Config

11.7.8.1 no ip rip authentication

This command sets the default RIP Version 2 Authentication Type.

Format `no ip rip authentication`

Mode Interface Config

11.7.9 ip rip receive version

This command configures the interface to allow RIP control packets of the specified version(s) to be received.

The value for <mode> is one of: rip1 to receive only RIP version 1 formatted packets, rip2 for RIP version 2, both to receive packets from either format, or none to not allow any RIP control packets to be received.

Default both

Format `ip rip receive version {rip1 | rip2 | both | none}`

Mode Interface Config

11.7.9.1 no ip rip receive version

This command configures the interface to allow RIP control packets of the default version(s) to be received.

Format `no ip rip receive version`

Mode Interface Config

11.7.10 ip rip send version

This command configures the interface to allow RIP control packets of the specified version to be sent.

The value for <mode> is one of: rip1 to broadcast RIP version 1 formatted packets, rip1c (RIP version 1 compatibility mode) which sends RIP version 2 formatted packets via broadcast, rip2 for sending RIP version 2 using multicast, or none to not allow any RIP control packets to be sent.

Default rip2

Format `ip rip send version {rip1 | rip1c | rip2 | none}`

Mode Interface Config

11.7.10.1 no ip rip send version

This command configures the interface to allow RIP control packets of the default version to be sent.

Format `no ip rip send version`

Mode `Interface Config`

11.7.11 *hostroutesaccept*

This command enables the RIP *hostroutesaccept* mode.

Default `enabled`

Format `hostroutesaccept`

Mode `Router RIP Config`

11.7.11.1 *no hostroutesaccept*

This command disables the RIP *hostroutesaccept* mode.

Format `no hostroutesaccept`

Mode `Router RIP Config`

11.7.12 *split-horizon*

This command sets the RIP split horizon mode.

Default `simple`

Format `split-horizon {none / simple / poison}`

Mode `Router RIP Config`

11.7.12.1 *no split-horizon*

This command sets the default RIP split horizon mode.

Format `no split-horizon`

Mode `Router RIP Config`

11.7.13 *redistribute*

This command configures RIP protocol to redistribute routes from the specified source protocol/routers. There are five possible match options. When you submit the command `redistribute ospf match <matchtype>` the match-type or types specified are added to any match types presently being redistributed. Internal routes are redistributed by default.

Default `metric -- not-configured; match -- internal`

Format `redistribute ospf [metric <0-15>] [match [internal] [external 1] [external 2]]`

[nssa-external 1] [nssa-external-2]] (for OSPF as source protocol)

Format redistribute {bgp | static | connected} [metric <0-15>] (for other source protocol)

Mode Router RIP Config

11.7.13.1 *no redistribute*

This command de-configures RIP protocol to redistribute routes from the specified source protocol/ routers.

Format no redistribute {ospf | bgp | static | connected} [metric] [match [internal] [external 1] [external 2] [nssa-external 1][nssa-external-2]]

Mode Router RIP Config

11.7.14 *show ip rip*

This command displays information relevant to the RIP router.

Format show ip rip

Mode Privileged EXEC and User EXEC

RIP Admin Mode Select enable or disable from the pulldown menu. If you select enable RIP will be enabled for the switch. The default is disable.

Split Horizon Mode Select none, simple or poison reverse from the pulldown menu. Split horizon is a technique for avoiding problems caused by including routes in updates sent to the router from which the route was originally learned. The options are: None - no special processing for this case. Simple - a route will not be included in updates sent to the router from which it was learned. Poisoned reverse - a route will be included in updates sent to the router from which it was learned, but the metric will be set to infinity. The default is simple

Auto Summary Mode Select enable or disable from the pulldown menu. If you select enable groups of adjacent routes will be summarized into single entries, in order to reduce the total number of entries The default is enable.

Host Routes Accept Mode Select enable or disable from the pulldown menu. If you select enable the router will be accept host routes. The default is enable.

Global Route Changes The number of route changes made to the IP Route Database by RIP. This does not include the refresh of a route's age.

Global queries -The number of responses sent to RIP queries from other systems.Default Metric Sets a default for the metric of redistributed routes.This field displays the default metric if one has already been set or blank if not configured earlier. The valid values are (1 to 15)

Default Metric Sets a default for the metric of redistributed routes.This field displays the default metric if one has already been set or blank if not configured earlier. The valid values are (1 to 15)

Default Route Advertise The default route.

11.7.15 *show ip rip interface brief*

This command displays general information for each RIP interface. For this command to

display successful results routing must be enabled per interface (i.e. ip rip).

Format show ip rip interface brief

Mode Privileged EXEC and User EXEC

Unit/Slot/Port Valid unit, slot and port number separated by forward slashes.

IP Address The IP source address used by the specified RIP interface.

Send Version The RIP version(s) used when sending updates on the specified interface. The types are none, RIP-1, RIP-1c, RIP-2.

Receive Version The RIP version(s) allowed when receiving updates from the specified interface. The types are none, RIP-1, RIP-2, Both

RIP Mode RIP administrative mode of router RIP operation; enable activates, disable de-activates it.

Link State The mode of the interface (up or down).

11.7.16 show ip rip interface

This command displays information related to a particular RIP interface.

Format show ip rip interface <unit/slot/port>

Mode Privileged EXEC and User EXEC

Interface Valid unit, slot and port number separated by forward slashes. This is a configured value.

IP Address The IP source address used by the specified RIP interface. This is a configured value.

Send version The RIP version(s) used when sending updates on the specified interface. The types are none, RIP-1, RIP-1c, RIP-2. This is a configured value.

Receive version The RIP version(s) allowed when receiving updates from the specified interface. The types are none, RIP-1, RIP-2, Both. This is a configured value.

Both RIP Admin Mode RIP administrative mode of router RIP operation; enable activates, disable de-activates it. This is a configured value.

Link State Indicates whether the RIP interface is up or down. This is a configured value.

Authentication Type The RIP Authentication Type for the specified interface. The types are none, simple, and encrypt. This is a configured value.

Default Metric A number which represents the metric used for default routes in RIP updates originated on the specified interface. This is a configured value.

The following information will be invalid if the link state is down.

Bad Packets Received The number of RIP response packets received by the RIP process which were subsequently discarded for any reason.

Bad Routes Received The number of routes contained in valid RIP packets that were ignored for any reason.

Updates Sent The number of triggered RIP updates actually sent on this interface.

12.0 Border Gateway Protocol (BGP) Commands

This chapter provides a detailed explanation of the Border Gateway Protocol (BGP) commands. The following BGP CLI commands are available in the our switch's BGP Package.

The commands are divided into the following different groups:

- Show commands are used to display device settings, statistics and other information.
- Configuration commands are used to configure features and options of the switch. For every configuration command there is a show command that will display the configuration setting.

Note: The command in this chapter are applied only for Layer 3 Series.

12.1 BGP Commands

12.1.1 *aggregate-address*

This command creates an address aggregation entry. The <prefix> is a valid IP address entry. The <mask> is the netmask for the ip address. A maximum of 10 entries can be added.

Default none
Format aggregate-address <prefix> <mask>

Mode Router BGP Config

12.1.1.1 *no aggregate-address* (only for Layer 3 Series)

This command deletes an address aggregation entry. The <prefix> is a valid IP address entry.

Format no aggregate-address <prefix> <mask>

Mode Router BGP Config

12.1.2 *bgp addrfamily create*

This command assigns the an Address Family with a Subsequent Address Family Identifier (SAFI). The AFI identifies a supported protocol, and is defined as having the value of IP version 4. The SAFI describes a sub-AFI value that is supported for the AFI. The possible values for <safi> are *unicast*, *multicast*, *both-unicast-multicast* and *labeldist*.

Default none

Format bgp addrfamily create <safi>

Mode Router BGP Config

12.1.2.1 *no bgp addrfamily create*

This command deletes the Address Family with the assigned Subsequent Address Family Identifier (SAFI). The AFI identifies a supported protocol, and is defined as having the value of IP version 4. The SAFI describes a sub-AFI value that is supported for the AFI. The possible values for <safi>

are unicast, multicast, both-unicast-multicast and labeledist.

Default none

Format no bgp addrfamily create <safi>

Mode Router BGP Config

12.1.3 *bgp autorestart*

This command informs the BGP4 module to enable automatic message sending in the case of connection failure.

Default disabled

Format bgp autorestart

Mode Router BGP Config

12.1.3.1 *no bgp autorestart*

This command informs the BGP4 module to disable automatic message sending in the case of connection failure.

Format no bgp autorestart

Mode Router BGP Config

12.1.4 *bgp calcmedmode*

This command informs the BGP4 module to enable or disable the use of the Calculated MED attribute. The MED attribute is used to describe the degree of preference of a particular link.

Default disabled

Format bgp calcmedmode

Mode Router BGP Config

12.1.4.1 *no bgp calcmedmode*

This command informs the BGP4 module to disable (set to default) the use of the Calculated MED attribute.

Format no bgp calcmedmode

Mode Router BGP Config

12.1.5 *bgp cluster-id*

This command assigns the cluster ID to which the router belongs. The Cluster value is a valid IP address.

Default 0.0.0.0

Format **bgp cluster-id** <clusterid>

Mode Router BGP Config

12.1.5.1 no bgp cluster-id

This command assigns the default cluster ID to which the router belongs.

Format **no bgp cluster-id**

Mode Router BGP Config

12.1.6 bgp community

This command specifies the associated community value for the route exchanges. The community attribute values range from 0x00000000 through 0x0000FFFF and 0xFFFF0000 through 0xFFFFFFFF are reserved. The rest of the community attribute values shall be encoded using an autonomous system number in the first two octets. The range for this field is 1 to 65535.

Default none

Format **bgp community** <1-65535>

Mode Router BGP Config

12.1.6.1 no bgp community

This command specifies the default associated community value for the route exchanges.

Default none

Format **no bgp community**

Mode Router BGP Config

12.1.7 bgp confederation identifier

This command assigns the external AS number that identifies the AS confederation. The range for this field is 1 to 65535.

Default 0

Format **bgp confederation identifier** <confedid>

Mode Router BGP Config

12.1.7.1 no bgp confederation identifier

This command resets the bgp confederation identifier value to its default.

Default 0

Format **no bgp confederation identifier**

12.1.8 *bgp default local-preference*

This command sets the local preference of the BGP4 router. The range for this field is -1 to 2147483647. A value of -1 indicates the absence of this attribute.

Default none

Format **bgp default local-preference <-1-2147483647>**

Mode Router BGP Config

12.1.8.1 *no bgp default local-preference*

This command sets the default value of local preference of the BGP4 router.

Format **no bgp default local-preference**

Mode Router BGP Config

12.1.9 *bgp flapdamping dampfactor*

This command configures the flap damping factor. The range for this field is 1 to 65535

Default 2

Format **bgp flapdamping dampfactor <dampfactor>**

Mode Router BGP Config

12.1.9.1 *no bgp flapdamping dampfactor*

This command configures the default flap damping factor. The range for this field is 1 to 65535.

Format **no bgp flapdamping dampfactor**

Mode Router BGP Config

12.1.10 *bgp flapdamping flapmaxtime*

This command configures the flap entry lifetime in seconds. The range for this field is 1 to 65535.

Default 900

Format **bgp flapdamping flapmaxtime <seconds>**

Mode Router BGP Config

12.1.10.1 *no bgp flapdamping flapmaxtime*

This command configures the default flap entry lifetime. The range for this field is 1 to 65535.

Format no bgp flapdamping flapmaxtime

Mode Router BGP Config

12.1.11 bgp flapdamping mode

This command enables the damping of the route flaps. Damping suppresses the advertisement of the route close to the route source until the route becomes stable. The possible values for this field are *enable* and *disable*.

Default disabled

Format bgp flapdamping mode

Mode Router BGP Config

12.1.11.1 no bgp flapdamping mode

This command disables the damping of the route flaps. Damping suppresses the advertisement of the route close to the route source until the route becomes stable. The possible values for this field are *enable* and *disable*.

Format no bgp flapdamping mode

Mode Router BGP Config

12.1.12 bgp flapdamping penaltyinc

This command configures the route damping penalty increment. The range for this field is 1 to 65535.

Default 100

Format bgp flapdamping penaltyinc <penalty>

Mode Router BGP Config

12.1.12.1 no bgp flapdamping penaltyinc

This command configures the default route damping penalty increment. The range for this field is 1 to 65535.

Format no bgp flapdamping penaltyinc

Mode Router BGP Config

12.1.13 bgp flapdamping reuselimit

This command configures the reuse limit of the flapped route. The range for this field is 1 to 65535.

Default 2

Format `bgp flapdamping reuselimit <limit>`

Mode Router BGP Config

12.1.13.1 no bgp flapdamping reuselimit

This command configures the default reuse limit of the flapped route.

Format `no bgp flapdamping reuselimit`

Mode Router BGP Config

12.1.14 bgp flapdamping reusemaxsize

This command configures the maximum reuse array size. The range for this field is 1 to 65535.

Default 1024

Format `bgp flapdamping reusemaxsize <size>`

Mode Router BGP Config

12.1.14.1 no bgp flapdamping reusemaxsize

This command configures the default reuse array size.

Format `no bgp flapdamping reusemaxsize`

Mode Router BGP Config

12.1.15 bgp flapdamping suppresslimit

This command configures the damping suppress limit of the route flaps. The range for this field is 1 to 65535.

Default 600

Format `bgp flapdamping suppresslimit <limit>`

Mode Router BGP Config

12.1.15.1 no bgp flapdamping suppresslimit

This command configures the default suppress limit of the route flaps.

Format `no bgp flapdamping suppresslimit`

Mode Router BGP Config

12.1.16 *bgp flapdamping timerresolution*

This command configures the delta time used in flap damping. The range for this field is 1 to 65535.

Default 2

Format `bgp flapdamping timerresolution <resolution>`

Mode Router BGP Config

12.1.16.1 *no bgp flapdamping timerresolution*

This command configures the default delta time used in flap damping.

Format `no bgp flapdamping timerresolution`

Mode Router BGP Config

12.1.17 *bgp interval minasorigin*

This command sets the time interval in seconds for the Minimum AS origination interval. The range for this field is 1 to 32767 seconds.

Default 15

Format `bgp interval minasorigin <1-32767>`

Mode Router BGP Config

12.1.17.1 *no bgp interval minasorigin*

This command sets the time interval to default for the Minimum AS origination interval.

Format `no bgp interval minasorigin`

Mode Router BGP Config

12.1.18 *bgp interval minrouteadvint*

This command sets the time interval in seconds for the Minimum Route Advertisement Interval (MinRouteAdInterval). This controls the frequency of route advertisements. The range for this field is 1 to 32767 seconds.

Default 30

Format `bgp interval minrouteadvint <1-32767>`

Mode Router BGP Config

12.1.18.1 *no bgp interval minrouteadvint*

This command sets the time interval to default for the Minimum Route Advertisement Interval (MinRouteAdInterval).

Format no bgp interval minrouteadvint

Mode Router BGP Config

12.1.19 *bgp localmed*

This command sets the local Multi-Exit-Discriminator (MED) value for the BGP4 router. This metric is used to discriminate between multiple exit points to an adjacent autonomous system. The range for this field is -1 to 2147483647. A value of -1 indicates the absence of this attribute.

Default none

Format bgp localmed <localmed>

Mode Router BGP Config

12.1.19.1 *no bgp localmed*

This command sets the local Multi-Exit-Discriminator (MED) value to default for the BGP4 router. This metric is used to discriminate between multiple exit points to an adjacent autonomous system.

Format no bgp localmed

Mode Router BGP Config

12.1.20 *bgp optionalcap*

This command enables the specified capability. Optional capabilities allow a BGP4 speaker to be aware of the protocol extension capabilities of a BGP4 neighbor. By default, all capabilities are disabled. The possible optional capabilities are *multiproto*, *routerreflect*, *community*, *confed*, and *all*. Each capability may be enabled or disabled.

Default disabled

Format bgp optionalcap <option>

Mode Router BGP Config

12.1.20.1 *no bgp optionalcap*

This command disables the specified capability. The possible optional capabilities are *multiproto*, *routerreflect*, *community*, *confed*, and *all*.

Format no bgp optionalcap <option>

Mode Router BGP Config

12.1.21 *bgp origin*

This command sets a value for the Origin attribute of the locally originated routes. The possible values for <origin> are *igp*, *egp*, and *incomplete*.

Default none

Format **bgp origin <origin>**

Mode Router BGP Config

12.1.22 *bgp policy*

This command creates a policy with an access mode of *permit* or *deny* and with the specified index. The possible value for the *<protocol>* are *bgpinternalin*, and *bgpinternalout*. The possible values for the *<matchtype>* are *aspath*, *origin*, *localpreference*, *multiexitdisc*, *community*, *confederationid*, *clusternumber*, *destippref*, *nexthop*, *lenaspath*, *peer*, *atomicaggregate*, *aggregatoras*, and *aggregatorid*. A maximum of 20 policies can be added.

Default none

Format **bgp policy <index> <access> <protocol> <matchtype>**

Mode Router BGP Config

12.1.22.1 *no bgp policy*

This command deletes a policy entry.

Format **no bgp policy <index>**

Mode Router BGP Config

12.1.23 *bgp policy action addint*

This command configures an 'add' action on the policy identified with the specified index. This command is used with matchtypes that use an integer as a modifier. The possible values for the *<matchtype>* are *aspath*, *origin*, *localpreference*, *multiexitdisc*, *community*, *confederationid*, *lenaspath*, *atomicaggregate*, and *aggregatoras*. The *<value>* parameter is an integer.

If the matchtype is *community*, the integer value is specified as a 32-bit number. The first 16 bits represent the AS number and the second 16 bits represent any arbitrary number. The combination of the 2 16-bit fields comprise the 32-bit community number. For example, a system with AS number 1 and using arbitrary number 256 might specify community as 65792 which is equivalent to 0x00010100.

The ranges for the matchtypes are as follows:

matchtype	range
aspath	1 to 65535
origin	1 to 3
localpreference	1 to 65535
multiexitdisc	1 to 65535
community	1 to 4294967295
confederationid	1 to 65535

lenaspath	1 to 65535
-----------	------------

matchtype	range
atomicaggregate	1 to 2
aggregatoras	0 to 65535

Default none

Format **bgp policy action addint <index> <matchtype> <value>**

Mode **Router BGP Config**

12.1.23.1 no bgp policy action addint

This command configures an 'add' action on the policy identified with the specified index. This command is used with matchtypes that use an integer as a modifier. The possible values for the <matchtype> are *aspath*, *origin*, *localpreference*, *multiexitdisc*, *community*, *confederationid*, *lenaspath*, *atomicaggregate*, and *aggregatoras*. The [value] parameter is an integer and is used only for match types of *aspath* and *community*

Format **no bgp policy action addint <index> <matchtype> [value]**

Mode **Router BGP Config**

12.1.24 bgp policy action addip

This command configures an 'add' action on the policy identified with the specified index. This command is used with matchtypes that use an IP Address as a modifier. The possible values for the <matchtype> are *clusternumber*, *destippref*, *nexthop*, and *aggregatorid*. The <ipaddr> parameter is an IP Address.

Default none

Format **bgp policy action addip <index> <matchtype> <ipaddr>**

Mode **Router BGP Config**

12.1.24.1 no bgp policy action addip

This command configures a 'delete' action on the policy identified with the specified index. This command is used with matchtypes that use an IP Address as a modifier. The possible values for the <matchtype> are *clusternumber*, *destippref*, *nexthop*, and *aggregatorid*. The <ipaddr> parameter is an IP Address.

Default none

Format **no bgp policy action addip <index> <matchtype> [ipaddr]**

Mode Router BGP Config

12.1.25 *bgp policy action remove*

This command removes an action identified by the *<matchtype>* from the policy identified with the specified index. The possible values for the *<matchtype>* are *aspath*, *origin*, *localpreference*, *multiexitdisc*, *community*, *confederationid*, *clusternumber*, *destippref*, *nexthop*, *lenaspath*, *peer*, *atomicaggregate*, *aggregatoras*, and *aggregatorid*.

If the matchtype is community, the integer value is specified as a 32-bit number. The first 16 bits represent the AS number and the second 16 bits represent any arbitrary number. The combination of the 2 16-bit fields comprise the 32-bit community number. For example, a system with AS number 1 and using arbitrary number 256 might specify community as 65792 which is equivalent to 0x00010100.

Default none

Format **bgp policy action remove** *<index>* *<matchtype>*

Mode Router BGP Config

12.1.26 *bgp policy range address*

This command adds a network IP address to a policy. The value for *<peerlocalid>* is an IP address. The value for *<mask>* is a network mask. Use a mask of 255.255.255.255 for an exact peer match.

Default none

Format **bgp policy range address** *<index>* *<peerlocalid>* *<mask>*

Mode Router BGP Config

12.1.27 *bgp policy range between*

This command adds a range to a policy identified by *<index>*. The range is specified by its outer bounds *<minvalue>* and *<maxvalue>*, which are from 1 to 4294967295.

Default none

Format **bgp policy range between** *<index>* *<minvalue>* *<maxvalue>*

Mode Router BGP Config

12.1.28 *bgp policy range equal*

This command adds a value equal-to specification to a policy identified by *<index>*. The *<value>* parameter is an integer from 0 to 4294967295.

Default none

Format **bgp policy range equal** *<index>* *<value>*

Mode Router BGP Config

12.1.29 bgp policy range greaterthan

This command adds a greater than range specification to a policy identified by *<index>*. The *<value>* parameter is an integer from 0 to 4294967295.

Default none

Format **bgp policy range greaterthan <index> <value>**

Mode Router BGP Config

12.1.30 bgp policy range lessthan

This command adds a less than range specification to a policy identified by *<index>*. The *<value>* parameter is an integer from 0 to 4294967295.

Default none

Format **bgp policy range lessthan <index> <value>**

Mode Router BGP Config

12.1.31 bgp policy range match

This command allows you to enter a string policy command.

Default none

Format **bgp policy range match <index> <string>**

Mode Router BGP Config

12.1.32 bgp policy range remove

This command removes a BGP4 policy range.

Format **bgp policy range remove <index>**

Mode Router BGP Config

12.1.33 bgp propmedmode

This command informs the BGP4 module to enable propagation of the MultiExitDisc (MED) metric. The possible values for this field are enable and disable.

Default disabled

Format **bgp propmedmode**

Mode Router BGP Config

12.1.33.1 *no bgp propmedmode*

This command informs the BGP4 module to disable propagation of the MultiExitDisc (MED) metric. The possible values for this field are enable and disable.

Format `no bgp propmedmode` **Border Gateway Protocol (BGP) Commands**

Mode Router BGP Config

12.1.34 *bgp router-id*

This command sets the system identification of the BGP Router. Generally, this is the Router IP Address. The Router IP Address will be taken as the default value unless this is explicitly configured.

Default 0.0.0.0

Format `bgp router-id <ipaddress>`

Mode Router BGP Config

12.1.34.1 *no bgp router-id*

This command sets the system identification of the BGP Router. Generally, this is the Router IP Address. The Router IP Address will be taken as the default value unless this is explicitly configured.

Format `no bgp router-id <ipaddress>`

Mode Router BGP Config

12.1.35 *bgp snpa*

This command builds the list of SNPAs (Subnet Point of Attachment) by adding each entered SNPA address and its length to the SNPA list. The SNPA address is a valid IP address. The SNPA length is a valid length of an SNPA address with a range of 1 to 128. A maximum of 10 SNPAs can be added.

Default none

Format `bgp snpa <snpaaddr> <snpalen>`

Mode Router BGP Config

12.1.35.1 *no bgp snpa*

This command removes the specified SNPA (Subnet Point of Attachment) entry from the list of SNPAs. The SNPA address is a valid IP address. The SNPA length is a valid length of an SNPA address with a range of 1 to 128.

Format `no bgp snpa <snpaaddr> <snpalen>`

Mode Router BGP Config

12.1.36 *bgp suppressmode*

This command informs the BGP4 module to enable the selection of less-specific routes. If this mode is enabled, more specific routes will be suppressed. The possible values for this field are *enable* and *disable*.

Default disabled

Format **bgp suppressmode**

Mode Router BGP Config

12.1.36.1 *no bgp suppressmode*

This command informs the BGP4 module to disable the selection of less-specific routes.

Format **no bgp suppressmode**

Mode Router BGP Config

12.1.37 *clear bgp*

This command resets the peer connection. This command should be used carefully as it could cause route flapping and overhead. The <neighboraddress> parameter specifies the neighboring BGP4 speaker's IP address.

Default none

Format **clear bgp <neighboraddress>**

Mode Privileged EXEC

12.1.38 *default-information originate (BGP)*

This command is used to control the advertisement of default routes.

Format **default-information originate**

Mode Router BGP Config

12.1.38.1 *no default-information originate (BGP)*

This command is used to control the advertisement of default routes.

Format **no default-information originate**

Mode Router BGP Config

12.1.39 *default-metric (BGP)*

This command is used to set a default for the metric of distributed routes.

Format default-metric <0-4294967295>

Mode Router BGP Config

12.1.39.1 no default-metric (BGP)

This command is used to set a default for the metric of distributed routes.

Format no default-metric

Mode Router BGP Config

12.1.40 distance bgp

This command sets the route preference value of BGP-4 routes in the router. Lower route preference values are preferred when determining the best route.

Default 170

Format distance bgp <2-255>

Mode Router BGP Config

12.1.40.1 no distance bgp

This command sets the default route preference value of BGP-4 routes in the router.

Format no distance bgp

Mode Router BGP Config

12.1.41 distribute-list out

This command is used to specify the access list to filter routes received from the source protocol.

Format distribute-list <1-199> out {rip | ospf | static | connected}

Mode Router BGP Config

12.1.41.1 no distribute-list out

This command is used to specify the access list to filter routes received from the source protocol.

Format no distribute-list <1-199> out {ospf | rip | static | connected}

Mode Router BGP Config

12.1.42 enable (BGP)

This command enables the administrative mode of BGP4 on the system.

Format enable

Mode Router BGP Config

12.1.42.1 no enable (BGP)

This command disables the administrative mode of BGP4 on the system.

Format no enable

Mode Router BGP Config

12.1.43 neighbor <peeripaddr> addrfamily

This command assigns an Address Family with a Subsequent Address Family Identifier (SAFI) to the peer. The AFI identifies a supported protocol, and the defined value is IP version 4. The SAFI describes a sub-AFI value that is supported for the AFI. The possible values for <saft> are *unicast*, *multicast*, *both-unicast-multicast* and *labeldist*. After executing this command, the BGP peer must be reset before the changes will take affect.

Default none

Format neighbor <peeripaddr> addrfamily <saft>

Mode Router BGP Config

12.1.43.1 no neighbor <peeripaddr> addrfamily

This command removes the Address Family with the assigned Subsequent Address Family Identifier (SAFI). The AFI identifies a supported protocol, and is defined as IP version 4. The SAFI describes a sub-AFI value that is supported for the AFI. The possible values for <saft> are *unicast*, *multicast*, *both-unicast-multicast* and *labeldist*. After executing this command, the BGP peer must be reset before the changes will take affect.

Default none

Format no neighbor <peeripaddr> addrfamily <saft>

Mode Router BGP Config

12.1.44 neighbor <peeripaddr> authentication none

This command configures (Sets to Default) the authentication type as none for a particular peer address.

Format neighbor <peeripaddr> authentication <none>

Mode Router BGP Config

12.1.45 neighbor <peeripaddr> authentication simple

This command configures the authentication as simple password and the key for a particular peer address. This will be used in OPEN messages to authenticate the peer connection. The key

parameter must be less than 16 characters long. After executing this command, the BGP peer must be reset before the changes will take effect.

Default <type> none [key] none

Format neighbor <peeripaddr> authentication <simple> [key]

Mode Router BGP Config

12.1.46 neighbor <peeripaddr> confedmember

This command enables the peer as a member of the confederation. The possible values for this field are enable and disable. After executing this command, the BGP peer must be reset before the changes will take effect.

Default disabled

Format neighbor <peeripaddr> confedmember

Mode Router BGP Config

12.1.46.1 no neighbor <peeripaddr> confedmember

This command disables the peer as a member of the confederation. The possible values for this field are enable and disable. After executing this command, the BGP peer must be reset before the changes will take effect.

Default disabled

Format no neighbor <peeripaddr> confedmember

Mode Router BGP Config

12.1.47 neighbor <peeripaddr> connretry

This command specifies the connection retry interval in seconds for a peer. The range is 1 to 65535 seconds.

Default 120

Format neighbor <peeripaddr> connretry <1-65535>

Mode Router BGP Config

12.1.47.1 no neighbor <peeripaddr> connretry

This command specifies the default connection retry interval for a peer.

Format no neighbor <peeripaddr> connretry

Mode Router BGP Config

12.1.48 neighbor <peeripaddr> msgsendlimit

This command configures the maximum number of messages in a peer transmission queue. The range for send limit is 1 to 100. The <peeripaddr> parameter specifies the neighboring BGP4 speaker's IP address.

Default 100

Format neighbor <peeripaddr> msgsendlimit <sendlimit>

Mode Router BGP Config

12.1.48.1 no neighbor <peeripaddr> msgsendlimit

This command configures the default number of messages in the peer transmission queue

Format no neighbor <peeripaddr> msgsendlimit <sendlimit>

Mode Router BGP Config

12.1.49 neighbor <peeripaddr> next-hop-self

This command enables the peer as the next hop for the locally originated paths. The possible values for this field are enable and disable. After executing this command, the BGP peer must be reset before the changes will take affect.

Default disabled

Format neighbor <peeripaddr> next-hop-self

Mode Router BGP Config

12.1.49.1 no neighbor <peeripaddr> next-hop-self

This command disables the peer as the next hop for the locally originated paths. After executing this command, the BGP peer must be reset before the changes will take affect.

Format no neighbor <peeripaddr> next-hop-self

Mode Router BGP Config

12.1.50 neighbor <peeripaddr> optionalcap

This command enables the specified capability for the peer connection. Optional capabilities allow a BGP4 speaker to be aware of the protocol extensions capabilities of a BGP4 neighbor. The possible optional capabilities are multiproto, routereflect, community, confed, and all. Each capability may be enabled or disabled. After executing this command, the BGP peer must be reset before the changes will take affect.

Default all capabilities are disabled

Format neighbor <peeripaddr> optionalcap

Mode Router BGP Config

12.1.50.1 no neighbor <peeripaddr> optionalcap

This command disables the specified capability for the peer connection

Format no neighbor <peeripaddr> optionalcap

Mode Router BGP Config

12.1.51 neighbor <peeripaddr> remote-as

This command assigns the remote Autonomous System (AS) Number for the peer. The range for this field is 1 to 65535. After executing this command, the BGP peer must be reset before the changes will take affect.

Default none

Format neighbor <peeripaddr> remote-as <peerasnumber>

Mode Router BGP Config

12.1.51.1 no neighbor <peeripaddr> [remote-as]

This command unassigns the remote Autonomous System (AS) Number for the peer. After executing this command, the BGP peer must be reset before the changes will take affect.

Default none

Format no neighbor <peeripaddr> [remote-as]

Mode Router BGP Config

12.1.52 neighbor <peeripaddr> maximum-prefix

This command configures maximum prefixes learned from a peer.

Default none

Format neighbor <peeripaddr> maximum-prefix <maximum> [<threshold>]
<warning-only>

Mode Router BGP Config

12.1.52.1 no neighbor <peeripaddr> maximum-prefix

This command unassigns the maximum prefixes learned from a peer.

Default none

Format no neighbor <peeripaddr> maximum-prefix <maximum> [<threshold>]
<warning-only>

Mode Router BGP Config

12.1.53 neighbor <peeripaddr> route-reflector-client

This command enables the route reflector client. A route reflector client relies on a route reflector to re-advertise its routes to the entire AS. The possible values for this field are *enable* and *disable*. After executing this command, the BGP peer must be reset before the changes will take effect.

Default disabled

Format neighbor <peeripaddr> route-reflector-client

Mode Router BGP Config

12.1.53.1 no neighbor <peeripaddr> route-reflector-client

This command disables the route reflector client. After executing this command, the BGP peer must be reset before the changes will take effect.

Format no neighbor <peeripaddr> route-reflector-client

Mode Router BGP Config

12.1.54 neighbor <peeripaddr> shutdown

This command disables the state of the BGP4 peer connection by stopping the connection mode. The <peeripaddr> parameter specifies the neighboring BGP4 speaker's IP address.

Default disabled

Format neighbor <peeripaddr> shutdown

Mode Router BGP Config

12.1.54.1 no neighbor <peeripaddr> shutdown

This command enables the state of the BGP4 peer connection by opening the connection mode. The <peeripaddr> parameter specifies the neighboring BGP4 speaker's IP address.

Format no neighbor <peeripaddr> shutdown

Mode Router BGP Config

12.1.55 neighbor <peeripaddr> timers <keepalive> <holdtime>

This command specifies the keep alive and hold time for a peer. This value is placed in an OPEN message sent to this peer by this BGP speaker. The possible values for keep alive field are 0 to 21845 seconds and for hold time field are 0 and 3 to 65535 seconds. After executing this command, the BGP peer must be reset before the changes will take affect

Default holdtime seconds

Default keepalive 90 seconds

Format neighbor <peeripaddr> timers <keepalive> <holdtime>

Mode Router BGP Config

12.1.55.1 no neighbor <peeripaddr> timers

This command specifies the default keep alive and hold time for a peer. After executing this command, the BGP peer must be reset before the changes will take affect

Format no neighbor <peeripaddr> timers

Mode Router BGP Config

12.1.56 neighbor <peeripaddr> txdelayint

This command configures the delay interval between two transmission sessions of MsgSendLimit packets. The range for this field is 1 to 5.

Default none

Format neighbor <peeripaddr> txdelayint <1-5>

Mode Router BGP Config

12.1.56.1 no neighbor <peeripaddr> txdelayint

This command configures the default delay interval between two transmission sessions of MsgSendLimit packets.

Format no neighbor <peeripaddr> txdelayint

Mode Router BGP Config

12.1.57 network

This command adds NLRI (Network Layer Reachability Information) to the BGP4 Router. The NLRI field contains a list of network numbers being advertised. The network number is a valid IP address entry. The [send | donotsend] field indicates whether or not this prefix should be sent. The <vpncos> field allows assignment of the VPN/COS identifier. A maximum of 10 NLRIs can be added.

Default none

Format network <networknumber> [mask <networkmask> [<vpncos> [<nexthop> [send | donotsend]]]]

Mode Router BGP Config

12.1.57.1 no network

This command removes NLRI (Network Layer Reachability Information) from the BGP4 Router. The Network number is a valid IP address entry.

Format no network <networknumber> [mask <networkmask>]

Mode Router BGP Config

12.1.58 redistribute

This command configures BGP protocol to redistribute routes from the specified source protocol/routers. RFC 1745 requires that the BGP/IDRP identifier must be equal to the OSPF router identifier at all times that the router is up. But in the current implementation, these two can be different.

Default value for metric not-configured

Default value for match internal

Format redistribute ospf [metric <0-4294967295>] [match [internal] [external 1] [external 2] [nssa-external 1] [nssa-external-2]] (for OSPF as source protocol)

Format redistribute {rip | static | connected} [metric <0-4294967295>] (for other source protocol)

Mode Router BGP Config

12.1.58.1 no redistribute

This command unconfigures redistribution for BGP protocol from the specified source protocol/routers.

Format no redistribute {ospf | bgp | static | connected} [metric] [match [internal] [external 1] [external 2] [nssa-external 1] [nssa-external-2]]

Mode Router BGP Config

12.1.59 route-aggregation

This command enables the usage of path address aggregation. The possible values for this field are *enable* and *disable*.

Default disabled

Format route-aggregation

Mode Router BGP Config

12.1.59.1 no route-aggregation

This command disables the usage of path address aggregation.

Format no route-aggregation

Mode Router BGP Config

12.1.60 route-reflect

This command enables route reflection mode. If this is enabled, the BGP4 speaker will re-advertise to other BGP4 neighbor's routes.

Default disabled

Format route-reflect

Mode Router BGP Config

12.1.60.1 no route-reflect

This command disables route reflection mode. If this is enabled, the BGP4 speaker will re-advertise to other BGP4 neighbor's routes.

Format no route-reflect

Mode Router BGP Config

12.1.61 trapflags

This command enables BGP4 trap flags.

Default disabled

Format trapflags

Mode Router BGP Config

12.1.61.1 no trapflags

This command disables BGP4 trap flags.

Format no trapflags

Mode Router BGP Config

12.1.62 show ip bgp

This command displays all the entries in the BGP4 route table.

Format `show ip bgp`

Mode `Privileged EXEC`

PeerId This displays the Peer ID for this entry in the BGP4 route table.

Prefix/Len This displays the prefix and the prefix length of this entry in the BGP4 route table.

NextHop This displays the Next Hop for this entry in the BGP4 route table.

VpncosId This displays the VPN/COS ID for this entry in the BGP4 route table.

12.1.63 show ip bgp addrfamilyinfo

This command displays the Address Family Identifier Info.

Format `show ip bgp addrfamilyinfo`

Mode `Privileged EXEC`

AFI This displays the Address Family Identifier (AFI).

SAFI This displays the Subsequent Address Family Identifier (SAFI).

12.1.64 show ip bgp aggregate-address

This command displays all the aggregation entries that are present in the aggregation list.

Format `show ip bgp aggregate-address`

Mode `Privileged EXEC`

Address Aggregation Mode This field displays whether Path Attribute Aggregation is enabled or disabled.

Prefix/Len This field displays the IP address which identifies the network and the prefix length.

12.1.65 show ip bgp brief

This command displays Border Gateway Protocol (BGP4) information and Route Redistribution information.

Format `show ip bgp brief`

Mode `User Exec`

Admin Mode This displays the administrative mode of Border Gateway Protocol (BGP4) for the system.

Version This displays the version of BGP4 running on the router.

Local Identifier The router ID of the BGP4 router. This is a configured value.

Local Autonomous System This represents the Autonomous number of the BGP4 router. This is a configured value.

Propagate MED Mode This indicates whether the MultiExitDisc (MED) propagation to internal links is enabled or disabled. This is a configured value.

Calculate MED Mode This indicates whether or not to take the MultiExitDisc (MED) metric into account when breaking a Phase 2 tie. This is a configured value.

Minimum AS Origination Interval This represents the time interval in seconds for the Minimum AS Origination Interval timer. This is a configured value.

Minimum Route Advertisement Interval This represents the time interval in seconds for the Minimum Route Advertisement Interval timer. This is a configured value.

Optional Capabilities supported This lists the optional capabilities supported by the BGP4 router. This is a configured value.

Route Reflector Mode This states whether or not this router is configured as a route reflector. This is a configured value.

Cluster ID This represents the cluster ID of the BGP4 router. This is a configured value.

Confederation ID This represents the AS confederation ID to which the BGP4 router belongs. This is a configured value.

Auto Restart Mode This states whether to automatically start message sending in the case of connection failure or not. This is a configured value.

Default-metric Default value for redistributed routes.

Default route advertise Indicates whether the default routes received from other source protocols are advertised or not.

Static Redistribution

Source Source protocol/routes that are being redistributed.

Metric-value Metric of the routes being redistributed.

Distribute-list The Access list used to filter redistributed routes.

RIP Redistribution

Source Source protocol/routes that are being redistributed.

Metric-value Metric of the routes being redistributed.

Distribute-list The Access list used to filter redistributed routes.

Connected Redistribution

Source Source protocol/routes that are being redistributed.

Metric-value Metric of the routes being redistributed.

Distribute-list The Access list used to filter redistributed routes.

OSPF Redistribution

Source Source protocol/routes that are being redistributed.

Metric-value Metric of the routes being redistributed.

Match-value The criteria by which OSPF routes are redistributed into other routing domains.

Distribute-list The Access list used to filter redistributed routes.

12.1.66 show ip bgp damping

This command displays all the information configured for BGP4 that relates to flap parameters. All the parameters are configurable.

Format `show ip bgp damping {dampened-paths | flap-statistics}`

Mode Privileged EXEC

Route Flap Mode This field indicates whether or not damping of the route flaps is enabled.

Suppress Limit This field displays the damping suppress limit for the route flaps.

Reuse Limit This field displays the reuse limit for the dampened routes.

Penalty Increment This field displays the penalty increment for the route flaps.

Delta Time This field is the delta time used for the dampened routes.

Flap Max Time This field displays the maximum flap entry time for the route.

Damping Factor This field is the exponential decay factor for the flapped routes.

Reuse Size This field displays the maximum reuse array size.

Prefix/Len This field displays the prefix and the prefix length for the entry in the route flap dampened table.

State This field indicates whether the route is suppressed, not suppressed, or reused.

Penalty Value This field indicates the accumulated penalty for the route.

Decay Decrement This field indicates the decay decrement for the entry in the route flap

dampened table.

Time Created This field indicates the time that this entry was created.

Time Suppressed This field indicates the suppressing time for this route

Event State This field indicates the event state for this entry in the route flap dampened table.

12.1.67 show ip bgp local

This command displays the local parameter information for the BGP4 object in the system. All the displayed parameters are configurable.

Format show ip bgp local

Mode Privileged EXEC

Route Local Origin This displays the value of the Local Origin attribute for the locally originated routes.

Route Local MED This displays the local MultiExitDisc (MED) value for the BGP4 router.

Route Local Preference This displays the Local Preference value used for the local originating routes.

Suppress Mode This indicates whether or not the selection of less-specific routes is suppressed. If this is set to *<enable>* then more specific routes will be suppressed.

Route Community This field displays the local associated community used for the locally originating routes.

Address Aggregation Mode This field states whether or not Address Aggregation is being used.

12.1.68 show ip bgp mplslabels

This command displays the MPLS (multi protocol label switching) information.

Format show ip bgp mplslabels <prefix> <prefixlen> <peerid> <vpncos>

Mode Privileged EXEC

Prefix This is the prefix of this entry in the BGP4 route table.

Prefix Length This is the prefix length of this entry in the BGP4 route table.

Peer ID This is the Peer ID for this entry in the BGP4 route table.

VPNCOS Id This is the VPN/COS ID for this entry in the BGP4 route table.

Labels This shows the labels for this entry in the BGP4 route table

12.1.69 *show ip bgp neighbors*

This command displays information about state and current activity of connections with the BGP4 peers.

Format `show ip bgp neighbors <peeripaddr>`

Mode Privileged EXEC and User EXEC

Remote Address The remote IP address of the BGP4 peer. This is a configured value.

Peer ID This is the unique identification number of the peer.

Peer Admin Status This states whether or not the peer is enabled. This is a configured value.

Peer State This represents the state of the peer connection.

Local Port This is the local port of the BGP4 router.

Remote AS This is the remote AS number of the BGP4 peer. This is a configured value.

Remote Port This is the remote port of the BGP4 peer.

Connect Retry Interval This is the time interval in seconds for the connection retry. This is a configured value.

Confederation Member This field indicates whether or not the peer is enabled as a confederation member. This is a configured value.

Optional Capabilities This lists the optional capabilities supported by the BGP4 router. This is a configured value.

Route Reflector Mode This states whether or not the peer is a route reflection client. This is a configured value.

Next Hop Self Mode This states whether or not the BGP4 router will configure itself as the next hop for the locally originated paths. This is a configured value.

Authentication Code This is the authentication mechanism being used between the peers. This is a configured value.

Local Interface Address This is the local interface address of the BGP4 router used as Next Hop to this peer when new local path is originated. This is a configured value.

Message Send Limit This states the maximum number of messages in the peer transmission queue for the BGP4 peer. This is a configured value.

Transmission Delay Interval This states the delay interval between two transmission sessions for the BGP4 peer. This is a configured value.

Negotiated Version This states the negotiated version between the peers.

Configured Hold Time This states the configured hold time between the peers.

Configured Keep Alive Time This states the configured keep alive time between the peers.

12.1.70 show ip bgp neighbors addrfamilyinfo

This command displays the BGP4 Peer Address Family Information.

Format show ip bgp neighbors addrfamilyinfo <peeripaddr>

Mode Privileged EXEC and User EXEC

AFI This displays the Address Family Identifier (AFI).

SAFI This displays the Subsequent Address Family Identifier (SAFI)

12.1.71 show ip bgp neighbors stats

This command displays the peer statistics for the specified peer. The <peeripaddr> parameter specifies the neighboring BGP4 speaker's IP address.

Format show ip bgp neighbors stats <peeripaddr>

Mode Privileged EXEC and User EXEC

Peer Admin Status This represents the state of the peer connection.

Remote Address This represents the IP address of the remote peer.

Updates Received This represents the total number of Update Packets received from the peer.

Updates Sent This represents the total number of Update Messages sent to the peer.

Total Messages Received This represents the total number of messages received from the peer.

Total Messages Sent This represents the total number of messages sent to the peer.

Last Error This states the last error seen on this connection.

Established Transitions This represents the total number of times the BGP4 FSM transitioned into the established state.

Established Time This represents the time the BGP peer has been in the established state.

Time Elapsed since Last Update This represents the time since the last update message was received from the specified BGP peer.

12.1.72 show ip bgp nrlolist

This command displays all the NLRI (Network Layer Reachability Information) entries in the BGP4

route table.

Format `show ip bgp nlrilist`

Mode Privileged EXEC

Prefix/len This displays the prefix and the prefix length of this entry in the NLRI list.

NextHop This displays the Next Hop for this entry in the NLRI List.

VpnCosId This displays the VPN/COS ID for this entry in the NLRI List.

Send Now This field indicates whether or not this prefix is being sent

12.1.73 show ip bgp pathattrtable

This command displays the BGP4 received path attribute table. This table contains one entry per path to a network, with path attributes received from all peers running BGP4.

Format `show ip bgp pathattrtable`

Mode Privileged EXEC

Peer ID The IP address of the peer for this path attribute.

Prefix/Length The network/prefix-length (i.e. route) for this path attribute.

Origin The origin of the information. This can have three values:

IGP - learned from an internal peer

EGP - learned from an external peer Incomplete - origin of information not known

ASPath Displays the segments of the ASPath (the path taken by the update through the different autonomous systems -- this path is used to prevent loops). If the path attribute has no value, it will show "empty".

NextHop The address of the router that will be the destination for traffic to the network of this path attribute.

MED This field displays the value of the MultiExitDisc (MED) metric which discriminates between multiple exit points to an adjacent autonomous system.

LocalPref This field indicates the preference for an advertised route, with higher values being preferred.

AtomicAggr This field indicates whether the BGP4 router has selected the less specific route or not.

AggrAS This field indicates the AS number of the most recent BGP4 router which performed route aggregation.

Aggregator This field indicates the IP address of the most recent BGP4 router which performed route aggregation.

CalcLocalPref This field indicates the degree of preference calculated by the receiving BGP4 router for an advertised route.

Best This field indicates whether this route is considered the best route from any routes that are available to choose from. If only one route is available, it will be considered best. It will show True / False.

Unknown Attributes This field indicates if there are any attributes in the received update that are of an unknown type to this version of BGP. Usually this field will contain "NONE". If there is a unknown attribute, it will show the content of that field.

12.1.74 show ip bgp peer-list

This command displays all the entries in the BGP4 Peer list.

Format `show ip bgp peer-list`

Mode **Privileged EXEC and User EXEC**

Peer Address This is the IP Address of the Peer.

12.1.75 show ip bgp policy brief

This command displays the policy table for the BGP4 router.

Format `show ip bgp policy brief`

Mode **Privileged EXEC Index** This displays the index of this entry in the policy table.

Protocol This displays the protocol that was assigned to this policy in the policy table.

MatchType This displays the match type associated with this policy.

permit/deny This indicates whether this policy entry has permit or deny access.

12.1.76 show ip bgp policy detailed

This command displays the details of a specified policy for the BGP4 router.

Format `show ip bgp policy detailed <index>`

Mode **Privileged EXEC**

Policy Index This displays the index of this entry in the policy table.

Protocol ID This displays the protocol that was assigned to this policy in the policy table.

Access Mode This indicates whether this policy entry has permit or deny access

Match Type This displays the match type associated with this policy. For each action configured for this policy, the following is displayed:

Action Type This indicates the type of action. Possible values are add, modify or delete.

Match Type The match type associated with this action.

Values The values associated with this match.

12.1.77 show ip bgp snpalist

This command displays the list of SNPAs (Subnet Point of Attachment) that have been added to the BGP4 router.

Format `show ip bgp snpalist`

Mode `Privileged EXEC`

SNPA Address This displays the SNPA IP Address of this entry in the table.

SNPA Length This displays the length of this SNPA address in the table.

12.1.78 show ip bgp trapflags

This command displays the status of the BGP4 trapflags.

Format `show ip bgp trapflags`

Mode `Router BGP Config`

BGP4 Traps This is the status of the BGP4 trapflags.

13.0 IP Multicast Commands

This chapter provides a detailed explanation of the IP Multicast commands. The following IP Multicast CLI commands are available in the switch's Multicast module.

Note: The command in this chapter are applied only for Layer 3 Series.

13.1 Multicast Commands

The following commands are used to configure IP Multicast.

13.1.1 *ip mcast boundary*

This command adds an administrative scope multicast boundary specified by <groupipaddr> and <mask> for which this multicast administrative boundary is applicable. <groupipaddr> is a group IP address and <mask> is a group IP mask.

Format ip mcast boundary <groupipaddr> <mask>

Mode Interface Config

13.1.1.1 *no ip mcast boundary*

This command deletes an administrative scope multicast boundary specified by <groupipaddr> and <mask> for which this multicast administrative boundary is applicable. <groupipaddr> is a group IP address and <mask> is a group IP mask.

Format no ip mcast boundary <groupipaddr> <mask>

Mode Interface Config

13.1.2 *ip multicast*

This command sets the administrative mode of the IP multicast forwarder in the router to active . For multicast routing to become operational, IGMP must be currently enabled. An error message will be displayed on the CLI if multicast routing is enabled while IGMP is disabled. However, the IP multicast mode configuration is stored in the multicast configuration file and is automatically enabled once IGMP is enabled.

Default disabled

Format ip multicast

Mode Global Config

13.1.2.1 *no ip multicast*

This command sets the administrative mode of the IP multicast forwarder in the router to inactive . For multicast routing to become operational, IGMP must be currently enabled. An error message will be displayed on the CLI if multicast routing is enabled while IGMP is disabled. However, the IP multicast mode configuration is stored in the multicast configuration file and is automatically

enabled once IGMP is enabled.

Format no ip multicast

Mode Global Config

13.1.3 ip multicast staticroute

This command creates a static route which is used to perform RPF checking in multicast packet forwarding. The combination of the `<sourceipaddr>` and the `<mask>` fields specify the network IP address of the multicast packet source. The `<groupipaddr>` is the IP address of the next hop toward the source. The `<metric>` is the cost of the route entry for comparison with other routes to the source network and is a value in the range of 0 and 255. The `current` incoming interface is used for RPF checking for multicast packets matching this multicast static route entry.

Default none

Format ip multicast staticroute `<sourceipaddr>` `<mask>` `<rpfipaddr>` `<metric>` `<unit/slot/port>`

Mode Global Config

13.1.3.1 no ip multicast staticroute

This command deletes a static route in the static mcast table. The `<sourceipaddr>` is the IP address of the multicast packet source.

Format no ip multicast staticroute `<sourceipaddr>`

Mode Global Config

13.1.4 ip multicast ttl-threshold

This command applies the given `<ttlthreshold>` to a routing interface. The `<ttlthreshold>` is the TTL threshold which is to be applied to the multicast Data packets which are to be forwarded from the interface. The value for `<ttlthreshold>` has range from 0 to 255.

Default 1

Format ip multicast ttl-threshold `<ttlvalue>`

Mode Interface Config

13.1.4.1 no ip multicast ttl-threshold

This command applies the default `<ttlthreshold>` to a routing interface. The `<ttlthreshold>` is the TTL threshold which is to be applied to the multicast Data packets which are to be forwarded from the interface.

Format no ip multicast ttl-threshold

Mode Interface Config

13.1.5 mrinfo

This command is used to query the neighbor information of a multicast-capable router specified by `[ipaddr]`. The default value is the IP address of the system at which the command is issued. The `mrinfo` command can take up to 2 minutes to complete. Only one `mrinfo` command may be in

process at a time. The results of this command will be available in the results buffer pool which can be displayed by using "show mrinfo".

Default none

Format mrinfo [<ipaddr>]

Mode Privileged EXEC

13.1.6 mstat

This command is used to find the IP Multicast packet rate and loss information path from a source to a receiver (unicast router id of the host running mstat). The results of this command will be available in the results buffer pool which can be displayed by using the command "show mstat" on page 255. If a debug command is already in progress, a message is displayed and the new request fails.

The <source> is the IP address of the remote multicast-capable source. The [receiver] is the IP address of the receiver. The default value is the IP address of the system at which the command is issued. The [group] is a multicast address of the group to be displayed. The default value is 224.2.0.1(the group used for the multicast backbone).

Note: The group and receiver IP addresses can be entered in any order.

Default none

Format mstat <source> [<group/receiver >] [<group/receiver>]

Mode Privileged EXEC

13.1.7 mtrace

This command is used to find the IP Multicast path from a source to a receiver (unicast router ID of the host running mtrace). A trace query is passed hop-by-hop along the reverse path from the receiver to the source, collecting hop addresses, packet counts, and routing error conditions along the path, and then the response is returned to the requestor. The results of this command are available in the results buffer pool which can be displayed by using the command "show mtrace" on page 255.

The <source> is the IP address of the remote multicast-capable source. The [receiver] is the IP address of the receiver. The default value is the IP address of system at which the command is issued. The [group] is the multicast address of the group to be displayed. The default value is 224.2.0.1(the group used for the multicast backbone). If a debug command is already in execution, a message is displayed and the new request fails.

Note: The group and destination IP addresses can be entered in any order.

Default none

Format mtrace <sourceipaddr> [<group/destination>] [<group/destination >]

Mode Privileged EXEC

13.1.8 show ip mcast

This command displays the system-wide multicast information.

Format `show ip mcast`

Modes Privileged EXEC User EXEC

Admin Mode This field displays the administrative status of multicast. This is a configured value.

Protocol State This field indicates the current state of the multicast protocol. Possible values are Operational or Non-Operational.

Table Max Size This field displays the maximum number of entries allowed in the multicast table.

Number Of Packets For Which Source Not Found This displays the number of packets for which the source is not found.

Number Of Packets For Which Group Not Found This displays the number of packets for which the group is not found.

Protocol This field displays the multicast protocol running on the router. Possible values are PIMDM, PIMSM, or DVMRP.

Entry Count This field displays the number of entries in the multicast table.

Highest Entry Count This field displays the highest entry count in the multicast table.

13.1.9 show ip mcast boundary

This command displays all the configured administrative scoped multicast boundaries.

Format `show ip mcast boundary {<unit/slot/port> | all}`

Modes Privileged EXEC User EXEC

Unit/Slot/Port Valid unit, slot and port number separated by forward slashes.

Group Ip The group IP address

Mask The group IP mask

13.1.10 show ip mcast interface

This command displays the multicast information for the specified interface.

Format `show ip mcast interface <unit/slot/port>`

Modes Privileged EXEC User EXEC

Unit/Slot/Port Valid unit, slot and port number separated by forward slashes.

TTL This field displays the time-to-live value for this interface.

13.1.11 *show ip mcast mroute*

This command displays a summary or all the details of the multicast table.

Format `show ip mcast mroute {detail | summary}`

Modes Privileged EXEC User EXEC

If the “detail” parameter is specified, the following fields are displayed:

Source IP Addr This field displays the IP address of the multicast data source.

Group IP Addr This field displays the IP address of the destination of the multicast packet.

Expiry Time This field displays the time of expiry of this entry in seconds.

Up Time This field displays the time elapsed since the entry was created in seconds.

RPF Neighbor This field displays the IP address of the RPF neighbor.

Flags This field displays the flags associated with this entry.

If the “summary” parameter is specified, the following fields are displayed:

Source IP Addr This field displays the IP address of the multicast data source.

Group IP Addr This field displays the IP address of the destination of the multicast packet.

Protocol This field displays the multicast routing protocol by which this entry was created.

Incoming Interface This field displays the interface on which the packet for this source/group arrives.

Outgoing Interface List This field displays the list of outgoing interfaces on which this packet is forwarded.

13.1.12 *show ip mcast mroute group*

This command displays the multicast configuration settings such as flags, timer settings, incoming and outgoing interfaces, RPF neighboring routers, and expiration times of all the entries in the multicast mroute table containing the given *<groupipaddr>*.

Format `show ip mcast mroute group <groupipaddr> {detail |summary}`

Modes Privileged EXEC User EXEC

Source IP Addr This field displays the IP address of the multicast data source.

Group IP Addr This field displays the IP address of the destination of the multicast packet.

Protocol This field displays the multicast routing protocol by which this entry was created.

Incoming Interface This field displays the interface on which the packet for this group arrives.

Outgoing Interface List This field displays the list of outgoing interfaces on which this packet is forwarded.

13.1.13 *show ip mcast mroute source*

This command displays the multicast configuration settings such as flags, timer settings, incoming and outgoing interfaces, RPF neighboring routers, and expiration times of all the entries in the multicast mroute table containing the given <sourceipaddr> or <sourceipaddr> [<groupipaddr>] pair.

Format `show ip mcast mroute source <sourceipaddr> {summary | <groupipaddr>}`

Modes Privileged EXEC User EXEC

If the detail parameter is specified the follow fields are displayed:

Source IP Addr This field displays the IP address of the multicast data source.

Group IP Addr This field displays the IP address of the destination of the multicast packet.

Expiry Time This field displays the time of expiry of this entry in seconds.

Up Time This field displays the time elapsed since the entry was created in seconds.

RPF Neighbor This field displays the IP address of the RPF neighbor.

Flags This field displays the flags associated with this entry.

If the summary parameter is specified the follow fields are displayed:

Source IP Addr This field displays the IP address of the multicast data source.

Group IP Addr This field displays the IP address of the destination of the multicast packet.

Protocol This field displays the multicast routing protocol by which this entry was created.

Interface This field displays the interface on which the packet for this source arrives.

Outgoing Interface List This field displays the list of outgoing interfaces on which this packet is forwarded.

13.1.14 *show ip mcast mroute static*

This command displays all the static routes configured in the static mcast table if is specified or displays the static route associated with the particular <sourceipaddr>.

Format `show ip mcast mroute static [<sourceipaddr>]`

Modes Privileged EXEC User EXEC

Source Address This field displays the IP address of the multicast packet source.

Source Mask This field displays the mask applied to the IP address of the multicast packet source.

RPF Address This field displays the IP address to be used as RPF for the given source and mask.

Metric This field displays the metric value corresponding to the source address.

Unit/Slot/Port Valid unit, slot and port number separated by forward slashes.

13.1.15 show mrinfo

This command is used to display the neighbor information of a multicast-capable router from the results buffer pool of the router subsequent to the execution/completion of a "mrinfo [ipaddr]" command. The results subsequent to the completion of the latest "mrinfo" will be available in the bufferpool after a maximum duration of two minutes after the completion of the 'show mrinfo' command. A subsequent issue 'mrinfo' will overwrite the contents of the buffer pool with fresh results.

Default none

Format show mrinfo

Mode Privileged EXEC

Router Interface The IP address of this neighbor

Neighbor The neighbor associated with the router interface

Metric The metric value associated with this neighbor

TTL The TTL threshold associated with this neighbor

Flags Status of the neighbor

13.1.16 show mstat

This command is used to display the results of packet rate and loss information from the results buffer pool of the router, subsequent to the execution/completion of a 'mstat <source> [group] [receiver]' command. Within two minutes of the completion of the 'mstat' command, the results will be available in the buffer pool. The next issuing of "mstat" would overwrite the buffer pool with fresh results.

Default none

Format show mstat

Mode Privileged EXEC

13.1.17 show mtrace

This command is used to display results of multicast trace path from the results buffer pool of the router, subsequent to the execution/completion of a "mtrace <source> [group] [receiver]" command. The results subsequent to the completion of the "mtrace" will be available in the buffer pool within 2

minutes and thereafter. A subsequent "mtrace" command would overwrite the results in the buffer pool.

Default none **Format** show mtrace

Modes Privileged EXEC User EXEC

Hops Away From Destination The ordering of intermediate routers between the source and the destination

Intermediate Router Address The address of the intermediate router at the specified hop distance

Mcast Protocol In Use The multicast routing protocol used for the out interface of the specified intermediate router.

TTL Threshold The Time-To-Live threshold of the out interface on the specified intermediate router.

Time Elapsed Between Hops (msecs) The time between arrival at one intermediate router to the arrival at the next.

13.2 Distance Vector Multicast Routing Protocol (DVMRP) Commands

This section provides a detailed explanation of the DVMRP commands. The commands are divided into the following different groups:

- Show commands are used to display device settings, statistics and other information.
- Configuration commands are used to configure features and options of the switch. For every configuration command there is a show command that will display the configuration setting.

13.2.1 *ip dvmrp*

This command sets administrative mode of DVMRP in the router to active. IGMP must be enabled before DVMRP can be enabled.

Default disabled

Format ip dvmrp

Mode Global Config

13.2.1.1 *no ip dvmrp*

This command sets administrative mode of DVMRP in the router to inactive. IGMP must be enabled before DVMRP can be enabled.

Format no ip dvmrp

Mode Global Config

13.2.2 *ip dvmrp metric*

This command configures the metric for an interface. This value is used in the DVMRP messages as the cost to reach this network. This field has a range of 1 to 63.

Default 1

Format ip dvmrp metric <metric>

Mode Interface Config

10.2.2.1 *no ip dvmrp metric*

This command resets the metric for an interface to the default value. This value is used in the DVMRP messages as the cost to reach this network.

Format no ip dvmrp metric **Mode** Interface Config

13.2.3 *ip dvmrp trapflags*

This command enables the DVMRP trap mode.

Default disabled
Format ip dvmrp trapflags
Mode Global Config

13.2.3.1 no ip dvmrp trapflags

This command disables the DVMRP trap mode.

Format no ip dvmrp trapflags

Mode Global Config

13.2.4 show ip dvmrp

This command displays the system-wide information for DVMRP.

Format show ip dvmrp

Modes Privileged EXEC User EXEC

Admin Mode This field indicates whether DVMRP is enabled or disabled. This is a configured value.

Version String This field indicates the version of DVMRP being used.

Number of Routes This field indicates the number of routes in the DVMRP routing table.

Reachable Routes This field indicates the number of entries in the routing table with non-infinite metrics.

The following fields are displayed for each interface.

Unit/Slot/Port Valid unit, slot and port number separated by forward slashes.

Interface Mode This field indicates the mode of this interface. Possible values are Enabled and Disabled.

State This field indicates the current state of DVMRP on this interface. Possible values are Operational or Non-Operational.

13.2.5 show ip dvmrp interface

This command displays the interface information for DVMRP on the specified interface.

Format show ip dvmrp interface <unit/slot/port>

Modes Privileged EXEC User EXEC

Interface Mode This field indicates whether DVMRP is enabled or disabled on the specified interface. This is a configured value.

Metric This field indicates the metric of this interface. This is a configured value.

Local Address This is the IP Address of the interface.

This Field is displayed only when DVMRP is operational on the interface.

Generation ID This is the Generation ID value for the interface. This is used by the neighboring routers to detect that the DVMRP table should be resent.

The following fields are displayed only if DVMRP is enabled on this interface.

Received Bad Packets This is the number of invalid packets received.

Received Bad Routes This is the number of invalid routes received.

Sent Routes This is the number of routes that have been sent on this interface.

13.2.6 *show ip dvmrp neighbor*

This command displays the neighbor information for DVMRP.

Format `show ip dvmrp neighbor`

Modes Privileged EXEC User EXEC

IfIndex This field displays the value of the interface used to reach the neighbor.

Nbr IP Addr This field indicates the IP Address of the DVMRP neighbor for which this entry contains information.

State This field displays the state of the neighboring router. The possible value for this field are ACTIVE or DOWN.

Up Time This field indicates the time since this neighboring router was learned.

Expiry Time This field indicates the time remaining for the neighbor to age out. This field is not applicable if the State is DOWN.

Generation ID This is the Generation ID value for the neighbor.

Major Version This shows the major version of DVMRP protocol of neighbor.

Minor Version This shows the minor version of DVMRP protocol of neighbor.

Capabilities This shows the capabilities of neighbor.

Received Routes This shows the number of routes received from the neighbor.

Rcvd Bad Pkts This field displays the number of invalid packets received from this neighbor.

Rcvd Bad Routes This field displays the number of correct packets received with invalid routes.

13.2.7 *show ip dvmrp nexthop*

This command displays the next hop information on outgoing interfaces for routing multicast datagrams.

Format `show ip dvmrp nexthop`

Modes Privileged EXEC User EXEC

Source IP This field displays the sources for which this entry specifies a next hop on an outgoing interface.

Source Mask This field displays the IP Mask for the sources for which this entry specifies a next hop on an outgoing interface.

Next Hop Interface This field displays the interface in unit/slot/port format for the outgoing interface for this next hop.

Type This field states whether the network is a LEAF or a BRANCH.

13.2.8 *show ip dvmrp prune*

This command displays the table listing the router's upstream prune information.

Format `show ip dvmrp prune`

Mode Privileged EXEC and User EXEC

Group IP This field identifies the multicast Address that is pruned.

Source IP This field displays the IP Address of the source that has pruned.

Source Mask This field displays the network Mask for the prune source. It should be all 1s or both the prune source and prune mask must match.

Expiry Time (secs) This field indicates the expiry time in seconds. This is the time remaining for this prune to age out.

13.2.9 *show ip dvmrp route*

This command displays the multicast routing information for DVMRP.

Format `show ip dvmrp route`

Mode Privileged EXEC and User EXEC

Source Address This field displays the multicast address of the source group.

Source Mask This field displays the IP Mask for the source group.

Upstream Neighbor This field indicates the IP Address of the neighbor which is the source for the packets for a specified multicast address.

Interface This field displays the interface used to receive the packets sent by the sources.

Metric This field displays the distance in hops to the source subnet. This field has a different meaning than the Interface Metric field.

Expiry Time(secs) This field indicates the expiry time in seconds. This is the time remaining for this route to age out.

Up Time(secs) This field indicates the time when a specified route was learnt, in seconds.

13.3 Internet Group Management Protocol (IGMP) Commands

This section provides a detailed explanation of the IGMP commands. The commands are divided into the following different groups:

- Show commands are used to display device settings, statistics and other information.
- Configuration commands are used to configure features and options of the switch. For every configuration command there is a show command that will display the configuration setting.

13.3.1 *ip igmp*

This command sets the administrative mode of IGMP in the router to active.

Default disabled

Format ip igmp

Mode Global Config

13.3.1.1 *no ip igmp*

This command sets the administrative mode of IGMP in the router to inactive.

Format no ip igmp

Mode Global Config

13.3.2 *ip igmp version*

This command configures the version of IGMP for an interface. The value for <version> is either 1, 2 or 3.

Default 3

Format ip igmp version <version>

Mode Interface Config

13.2.1 *no ip igmp version*

This command resets the version of IGMP for this interface. The version is reset to the default value.

Format no ip igmp version

Mode Interface Config

13.3.3 *set igmp mcrtpexpiretime*

This command sets the Multicast Router Present Expiration time on the system. This is the amount of time in seconds that a switch will wait for a query to be received on an interface before the

interface is removed from the list of interfaces with multicast routers attached. The range is 0 to 3600 seconds. A value of 0 indicates an infinite timeout, i.e. no expiration.

Default 0

Format `set igmp mcartrexpertime <0-3600>`

Mode Global Config

13.3.3.1 no set igmp mcartrexpertime

This command sets the Multicast Router Present Expiration time on the system to 0. A value of 0 indicates an infinite timeout, i.e. no expiration.

Format `no set igmp mcartrexpertime`

Mode Global Config

13.3.4 ip igmp last-member-query-count

This command sets the number of Group-Specific Queries sent before the router assumes that there are no local members on the interface. The range for *<count>* is 1 to 20.

Format `ip igmp last-member-query-count <count>`

Mode Interface Config

13.3.4.1 no ip igmp last-member-query-count

This command resets the number of Group-Specific Queries to the default value.

Format `no ip igmp last-member-query-count`

Mode Interface Config

13.3.5 ip igmp last-member-query-interval

This command configures the Maximum Response Time being inserted into Group-Specific Queries sent in response to Leave Group messages on the interface. The range for *<seconds>* is 0 to 255 tenths of a second.

Default 10 tenths of a second (1 second)

Format `ip igmp last-member-query-interval <seconds>`

Mode Interface Config

13.3.5.1 no ip igmp last-member-query-interval

This command resets the Maximum Response Time being inserted into Group-Specific Queries sent in response to Leave Group messages on the interface to the default value.

Format `no ip igmp last-member-query-interval`

Mode Interface Config

13.3.6 ip igmp query-interval

This command configures the query interval for the specified interface. This is the frequency at which IGMP Host-Query packets are transmitted on this interface. The range for *<queryinterval>* is 1 to 3600 seconds.

Default 125 seconds

Format ip igmp query-interval *<seconds>*

Mode Interface Config

13.3.6.1 no ip igmp query-interval

This command resets the query interval for the specified interface to the default value. This is the frequency at which IGMP Host-Query packets are transmitted on this interface.

Format no ip igmp query-interval

Mode Interface Config

13.3.7 ip igmp query-max-response-time

This command configures the maximum response time interval for the specified interface, which is the maximum query response time advertised in IGMPv2 queries on this interface. The time interval is specified in tenths of a second. The range for *<maxresptime>* is 0 to 255 tenths of a second.

Default 100

Format ip igmp query-max-response-time *<seconds>*

Mode Interface Config

13.3.7.1 no ip igmp query-max-response-time

This command resets the maximum response time interval for the specified interface, which is the maximum query response time advertised in IGMPv2 queries on this interface to the default value. The maximum response time interval is reset to the default time.

Format no ip igmp query-max-response-time

Mode Interface Config

13.3.8 ip igmp robustness

This command configures the robustness that allows tuning of the interface. The robustness is the tuning for the expected packet loss on a subnet. If a subnet is expected to have a lot of loss, the Robustness variable may be increased for the interface. The range for *<robustness>* is 1 to 255.

Default 2

Format ip igmp robustness <robustness>

Mode nterface Config

13.3.8.1 no ip igmp robustness

This command sets the robustness value to default.

Format no ip igmp robustness

Mode Interface Config

13.3.9 ip igmp startup-query-count

This command sets the number of Queries sent out on startup, separated by the Startup Query Interval on the interface. The range for <count> is 1 to 20.

Default 2

Format ip igmp startup-query-count <count>

Mode nterface Config

13.3.9.1 no ip igmp startup-query-count (only for Layer 3 Series)

This command resets the number of Queries sent out on startup, separated by the Startup Query Interval on the interface to the default value.

Format no ip igmp startup-query-count

Mode Interface Config

13.3.10 ip igmp startup-query-interval

This command sets the interval between General Queries sent by a Querier on startup on the interface. The time interval value is in seconds. The range for <interval> is 1 to 300 seconds.

Default 31

Format ip igmp startup-query-interval <interval>

Mode Interface Config

13.3.10.1 no ip igmp startup-query-interval

This command resets the interval between General Queries sent by a Querier on startup on the interface to the default value.

Format no ip igmp startup-query-interval

Mode Interface Config

13.3.11 set igmp groupmembershipinterval

This command sets the IGMP Group Membership Interval time on a particular interface or VLAN. The Group Membership Interval time is the amount of time in seconds that a switch will wait for a report from a particular group on a particular interface before deleting the interface from the entry. This value must be greater than the IGMPv3 Maximum Response time value. The range is 2 to 3600 seconds.

Default 260 seconds

Format set igmp groupmembershipinterval <vlanId> <2-3600>

Mode Interface Config Vlan Mode

13.3.11.1 no set igmp groupmembershipinterval

This command sets the IGMPv3 Group Membership Interval time (on the interface or the VLAN) to the default value.

Format no set igmp groupmembershipinterval

Mode Interface Config Vlan Mode

13.3.12 set igmp maxresponse

This command sets the IGMP Maximum Response time for the system, on a particular interface or VLAN. The Maximum Response time is the amount of time in seconds that a switch will wait after sending a query on an interface because it did not receive a report for a particular group in that interface. This value must be less than the IGMP Query Interval time value. The range is 1 to 3599 seconds.

Default 10 seconds

Format set igmp maxresponse <1-3599>

Mode Global Config Interface Config Vlan Mode

13.3.12.1 no set igmp maxresponse

This command sets the IGMP Maximum Response time (on the interface or VLAN) to the default value.

Format no set igmp maxresponse

Mode Global Config Interface Config Vlan Mode

13.3.13 set igmp mrouter interface

This command configures a selected interface as a multicast router interface. When configured as a multicast router interface, the interface is treated as a multicast router interface in all VLANs.

Default disable

Format set igmp mrouter interface

Mode Interface Config

13.3.13.1 no set igmp mrouter interface

This command disables the status of the interface as a statically configured multicast router interface.

Format no set igmp mrouter interface

Mode Interface Config

13.3.14 set igmp mrouter

This command configures the VLAN ID(<vlanId>) that has the multicast router mode enabled.

Format set igmp mrouter <vlanId>

Mode Interface Config

13.3.14.1 no set igmp mrouter

This command disables multicast router mode for a particular VLAN ID (<vlanId>).

Format no set igmp mrouter <vlanId>

Mode Interface Config

13.3.15 show ip igmp

This command displays the system-wide IGMP information.

Format show ip igmp

Modes Privileged EXEC User EXEC

IGMP Admin Mode This field displays the administrative status of IGMP. This is a configured value.

Unit/Slot/Port Valid unit, slot and port number separated by forward slashes.

Interface Mode This field indicates whether IGMP is enabled or disabled on the interface. This is a configured value.

Protocol State This field indicates the current state of IGMP on this interface. Possible values are Operational or Non-Operational.

13.3.16 *show ip igmp groups*

This command displays the registered multicast groups on the interface. If “detail” is specified this command displays the registered multicast groups on the interface in detail.

Format `show ip igmp groups <unit/slot/port> [detail]`

Mode Privileged EXEC

If detail is not specified, the following fields are displayed:

IP Address This displays the IP address of the interface participating in the multicast group.

Subnet Mask This displays the subnet mask of the interface participating in the multicast group.

Interface Mode This displays whether IGMP is enabled or disabled on this interface.

The following fields are not displayed if the interface is not enabled:

Querier Status This displays whether the interface has IGMP in Querier mode or Non-Querier mode.

Groups This displays the list of multicast groups that are registered on this interface.

If detail is specified, the following fields are displayed:

Multicast IP Address This displays the IP Address of the registered multicast group on this interface.

Last Reporter This displays the IP Address of the source of the last membership report received for the specified multicast group address on this interface.

Up Time This displays the time elapsed since the entry was created for the specified multicast group address on this interface.

Expiry Time This displays the amount of time remaining to remove this entry before it is aged out.

Version1 Host Timer This displays the time remaining until the local router will assume that there are no longer any IGMP version 1 multicast members on the IP subnet attached to this interface. This could be an integer value or “-----” if there is no Version 1 host present.

Version2 Host Timer This displays the time remaining until the local router will assume that there are no longer any IGMP version 2 multicast members on the IP subnet attached to this interface. This could be an integer value or “-----” if there is no Version 2 host present.

Group Compatibility Mode The group compatibility mode (v1, v2 or v3) for this group on the specified interface.

13.3.17 *show ip igmp interface*

This command displays the IGMP information for the interface.

Format `show ip igmp interface <unit/slot/port>`

Modes Privileged EXEC User EXEC

Unit/Slot/Port Valid unit, slot and port number separated by forward slashes.

IGMP Admin Mode This field displays the administrative status of IGMP. This is a configured value.

Interface Mode This field indicates whether IGMP is enabled or disabled on the interface. This is a configured value.

IGMP Version This field indicates the version of IGMP running on the interface. This value can be configured to create a router capable of running either IGMP version 1 or 2.

Query Interval This field indicates the frequency at which IGMP Host-Query packets are transmitted on this interface. This is a configured value.

Query Max Response Time This field indicates the maximum query response time advertised in IGMPv2 queries on this interface. This is a configured value.

Robustness This field displays the tuning for the expected packet loss on a subnet. If a subnet is expected to have a lot of loss, the Robustness variable may be increased for that interface. This is a configured value.

Startup Query Interval This value indicates the interval between General Queries sent by a Querier on startup. This is a configured value.

Startup Query Count This value is the number of Queries sent out on startup, separated by the Startup Query Interval. This is a configured value.

Last Member Query Interval This value indicates the Maximum Response Time inserted into Group-Specific Queries sent in response to Leave Group messages. This is a configured value.

Last Member Query Count This value is the number of Group-Specific Queries sent before the router assumes that there are no local members. This is a configured value.

13.3.18 *show ip igmp interface membership*

This command displays the list of interfaces that have registered in the multicast group.

Format `show ip igmp interface membership <multiipaddr> [detail]`

Mode Privileged EXEC

Interface Valid unit, slot and port number separated by forward slashes.

Interface IP This displays the IP address of the interface participating in the multicast group.

State This displays whether the interface has IGMP in Querier mode or Non-Querier mode.

Group Compatibility Mode The group compatibility mode (v1, v2 or v3) for the specified group on this interface.

Source Filter Mode The source filter mode (Include/Exclude) for the specified group on this interface. This is "-----" for IGMPv1 and IGMPv2 Membership Reports.

If detail is specified, the following fields are displayed:

Interface Valid unit, slot and port number separated by forward slashes.

Group Compatibility Mode The group compatibility mode (v1, v2 or v3) for the specified group on this interface.

Source Filter Mode The source filter mode (Include/Exclude) for the specified group on this interface. This is "-----" for IGMPv1 and IGMPv2 Membership Reports.

Source Hosts This displays the list of unicast source IP Addresses in the group record of the IGMPv3 Membership Report with the specified multicast group IP Address. This is "-----" for IGMPv1 and IGMPv2 Membership Reports.

Expiry Time This displays the amount of time remaining to remove this entry before it is aged out. This is "----" for IGMPv1 and IGMPv2 Membership Reports.

13.3.19 show ip igmp interface stats

This command displays the IGMP statistical information for the given interface. The statistics are only displayed when the interface is enabled for IGMP.

Format `show ip igmp interface stats <unit/slot/port>`

Modes Privileged EXEC User EXEC

Querier Status This field indicates the status of the IGMP router, whether it is running in Querier mode or Non-Querier mode.

Querier IP Address This field displays the IP Address of the IGMP Querier on the IP subnet to which this interface is attached.

Querier Up Time This field indicates the time since the interface Querier was last changed.

Querier Expiry Time This field displays the amount of time remaining before the Other Querier Present Timer expires. If the local system is the querier, the value of this object is zero.

Wrong Version Queries This field indicates the number of queries received whose IGMP version does not match the IGMP version of the interface.

Number of Joins This field displays the number of times a group membership has been added on this interface.

Number of Groups This field indicates the current number of membership entries for this interface

13.4 Protocol Independent Multicast - Dense Mode (PIM-DM) Commands

This section provides a detailed explanation of the PIM-DM commands. The commands are divided into the following different groups:

- □ Show commands are used to display device settings, statistics and other information. □
- Configuration commands are used to configure features and options of the switch. For every configuration command there is a show command that will display the configuration setting.

13.4.1 *ip pimdm*

This command enables the administrative mode of PIM-DM in the router.

Default disabled

Format ip pimdm

Mode Global Config

13.4.1.1 *no ip pimdm*

This command disables the administrative mode of PIM-DM in the router. IGMP must be enabled before PIM-DM can be enabled.

Format no ip pimdm

Mode Global Config

13.4.2 *ip pimdm mode*

This command sets administrative mode of PIM-DM on an interface to enabled.

Default disabled

Format ip pimdm mode <unit/slot/port>

Mode Interface Config

13.4.2.1 *no ip pimdm mode*

This command sets administrative mode of PIM-DM on an interface to disabled.

Format no ip pimdm mode <unit/slot/port>

Mode Interface Config

13.4.3 *ip pimdm query-interval*

This command configures the transmission frequency of hello messages between PIM enabled neighbors. This field has a range of 10 to 3600 seconds.

Default 30

Format `ip pimdm query-interval <seconds>`

Mode Interface Config

13.4.3.1 *no ip pimdm query-interval*

This command resets the transmission frequency of hello messages between PIM enabled neighbors to the default value.

Format `no ip pimdm query-interval`

Mode Interface Config

13.4.4 *show ip pimdm*

This command displays the system-wide information for PIM-DM.

Format `show ip pimdm`

Mode Privileged EXEC and User EXEC

PIM-DM Admin Mode This field indicates whether PIM-DM is enabled or disabled. This is a configured value.

Unit/Slot/Port Valid unit, slot and port number separated by forward slashes.

Interface Mode This field indicates whether PIM-DM is enabled or disabled on this interface. This is a configured value.

State This field indicates the current state of PIM-DM on this interface. Possible values are Operational or Non-Operational.

13.4.5 *show ip pimdm interface*

This command displays the interface information for PIM-DM on the specified interface.

Format `show ip pimdm interface <unit/slot/port>`

Mode Privileged EXEC and User EXEC

Interface Mode This field indicates whether PIM-DM is enabled or disabled on the specified interface. This is a configured value.

PIM-DM Interface Hello Interval This field indicates the frequency at which PIM hello messages are transmitted on this interface. By default, the value is 30 seconds.

13.4.6 show ip pimdm interface stats

This command displays the statistical information for PIM-DM on the specified interface.

Format show ip pimdm interface stats {<unit/slot/port> | all}

Mode Privileged EXEC and User EXEC

Interface Valid unit, slot and port number separated by forward slashes.

IP Address This field indicates the IP Address that represents the PIM-DM interface.

Nbr Count This field displays the neighbor count for the PIM-DM interface.

Hello Interval This field indicates the time interval between two hello messages sent from the router on the given interface.

Designated Router This indicates the IP Address of the Designated Router for this interface.

13.4.7 show ip pimdm neighbor

This command displays the neighbor information for PIM-DM on the specified interface.

Format show ip pimdm neighbor {<unit/slot/port> | all}

Mode Privileged EXEC and User EXEC

Neighbor Address This field displays the IP Address of the neighbor on an interface.

Interface Valid unit, slot and port number separated by forward slashes.

Up Time This field indicates the time since this neighbor has become active on this interface.

Expiry Time This field indicates the expiry time of the neighbor on this interface.

13.4.8 show ip pimdm componenttable

This command displays the table containing objects to a PIM domain.

Format show ip pimdm componenttable

Mode Privileged EXEC and User EXEC

13.5 Protocol Independent Multicast - Sparse Mode(PIM-SM) Commands

This section provides a detailed explanation of the PIM-SM commands. The commands are divided into the following different groups:

- Show commands are used to display device settings, statistics and other information. □
- Configuration commands are used to configure features and options of the switch. For every configuration command there is a show command that will display the configuration setting.

13.5.1 *ip pimsm cbsrpreference*

This command is used to configure the CBSR preference for a particular PIM-SM interface. The range of CBSR preference is -1 to 255.

Default 0

Format ip pimsm cbsrpreference <-1-255>

Mode Interface Config

13.5.1.1 *no ip pimsm cbsrpreference*

This command is used to reset the CBSR preference for a particular PIM-SM interface to the default value.

Format no ip pimsm cbsrpreference

Mode Interface Config

13.5.2 *ip pimsm cbsrhashmasklength*

This command is used to configure the CBSR hash mask length to be advertised in bootstrap messages for a particular PIM-SM interface. This hash mask length will be used in the hash algorithm for selecting the RP for a particular group. The valid range is 0 - 32. The default value is 30.

Default 30

Format ip pimsm cbsrhashmasklength <0-32>

Mode Interface Config

13.5.2.1 *no ip pimsm cbsrhashmasklength*

This command is used to reset the CBSR hash mask length for a particular PIM-SM interface to the default value.

Format no ip pimsm cbsrhashmasklength

Mode Interface Config

13.5.3 ip pimsm crppreference

This command is used to configure the Candidate Rendezvous Point (CRP) for a particular PIM-SM interface. The valid values are from (-1 to 255), and the value of -1 is used to indicate that the local interface is not a Candidate RP interface.

The active router interface, with the highest IP Address and crppreference greater than -1, is chosen as the CRP for the router. The default value is 0. In the CRP advertisements sent to the bootstrap router (BSR), the router interface advertises itself as the CRP for the group range 224.0.0.0 mask 240.0.0.0.

Default 0

Format ip pimsm crppreference <-1-255>

Mode Interface Config

13.5.3.1 no ip pimsm crppreference

This command is used to reset the Candidate Rendezvous Point (CRP) for a particular PIM-SM interface to the default value.

Format no ip pimsm crppreference

Mode Interface Config

13.5.4 ip pimsm message-interval

This command is used to configure the global join/prune interval for PIM-SM router. The join/prune interval is specified in seconds. This parameter can be configured to a value from 10 to 3600.

Default 60

Format ip pimsm message-interval <10-3600>

Mode Global Config

13.5.4.1 no ip pimsm message-interval

This command is used to reset the global join/prune interval for PIM-SM router to the default value.

Format no ip pimsm message-interval

Mode Global Config

13.5.5 *ip pimsm*

This command sets administrative mode of PIM-SM multicast routing across the router to enabled. IGMP must be enabled before PIM-SM can be enabled.

Default disabled

Format ip pimsm

Mode Global Config

13.5.5.1 *no ip pimsm*

This command sets administrative mode of PIM-SM multicast routing across the router to disabled. IGMP must be enabled before PIM-SM can be enabled.

Format no ip pimsm

Mode Global Config

13.5.6 *ip pimsm mode*

This command sets administrative mode of PIM-SM multicast routing on a routing interface to enabled.

Default disabled

Format ip pimsm mode

Mode Interface Config

13.5.6.1 *no ip pimsm mode*

This command sets administrative mode of PIM-SM multicast routing on a routing interface to disabled.

Format no ip pimsm mode

Mode Interface Config

13.5.7 *ip pimsm query-interval*

This command configures the transmission frequency of hello messages in seconds between PIM enabled neighbors. This field has a range of 10 to 3600 seconds.

Default 30

Format ip pimsm query-interval <10-3600>

Mode Interface Config

13.5.7.1 no ip pimsm query-interval

This command resets the transmission frequency of hello messages between PIM enabled neighbors to the default value.

Format no ip pimsm query-interval

Mode Interface Config

13.5.8 ip pimsm spt-threshold

This command is used to configure the Threshold rate for the RP router to switch to the shortest path. The rate is specified in Kilobytes per second. The possible values are 0 to 2000.

Default 50

Format ip pimsm spt-threshold <0-2000>

Mode Global Config

13.5.8.1 no ip pimsm spt-threshold

This command is used to reset the Threshold rate for the RP router to switch to the shortest path to the default value.

Format no ip pimsm spt-threshold

Mode Global Config

13.5.9 ip pim-trapflags

This command enables the PIM trap mode for both Sparse Mode (SM) and Dense Mode. (DM).

Default disabled

Format ip pim-trapflags

Mode Global Config

13.5.9.1 no ip pim-trapflags

This command disables the PIM trap mode.

Format no ip pim-trapflags

Mode Global Config

13.5.10 ip pimsm staticrp

This command is used to create RP IP address for the PIM-SM router. The parameter <ipaddress> is the IP address of the RP. The parameter <groupaddress> is the group address supported by the RP. The parameter <groupmask> is the group mask for the group address.

Default disabled

Format ip pimsm staticrp <ipaddress> <groupaddress> <groupmask>

Mode Global Config

13.5.10.1 no ip pimsm staticrp

This command is used to delete RP IP address for the PIM-SM router. The parameter <ipaddress> is the IP address of the RP. The parameter <groupaddress> is the group address supported by the RP. The parameter <groupmask> is the group mask for the group address.

Format no ip pimsm staticrp <ipaddress> <groupaddress> <groupmask>

Mode Global Config

13.5.11 ip pimsm register-rate-limit

This command the register threshold rate for PIM-SM..

Default disabled

Format ip pimsm register-rate-limit <0-2000>

Mode Global Config

13.5.12 show ip pimsm rphash

This command displays the RP router that will be selected from the set of active RP routers. The RP router, for the group, is selected by using the hash algorithm defined in RFC 2362.

Format show ip pimsm rphash <groupaddress>

Mode Privileged EXEC and User EXEC

CRP IP Address This field displays the IP address of the RP.

Group Mask This field displays the group mask for the group address.

13.5.13 show ip pimsm staticrp

This command displays the static RP information for the PIM-SM router.

Format `show ip pimsm staticrp`

Mode Privileged EXEC and User EXEC

CRP IP Address This field displays the IP address of the RP.

Group Address This field displays the group address supported by the RP.

Group Mask This field displays the group mask for the group address..

13.5.14 show ip pimsm

This command displays the system-wide information for PIM-SM.

Format `show ip pimsm`

Mode Privileged EXEC and User EXEC

PIM-SM Admin Mode This field indicates whether PIM-SM is enabled or disabled. This is a configured value.

Join/Prune Interval (secs) This field shows the interval at which periodic PIM-SM Join/Prune messages are to be sent. This is a configured value.

Data Threshold Rate (K bits/sec) This field shows the data threshold rate for the PIM-SM router. This is a configured value.

Register Threshold Rate (K bits/sec) This field indicates the threshold rate for the RP router to switch to the shortest path. This is a configured value.

Unit/Slot/Port Valid unit, slot and port number separated by forward slashes.

Interface Mode This field indicates whether PIM-SM is enabled or disabled on the interface. This is a configured value.

Protocol State This field indicates the current state of the PIM-SM protocol on the interface. Possible values are Operational or Non-Operational.

13.5.15 show ip pimsm componenttable

This command displays the table containing objects specific to a PIM domain. One row exists for each domain to which the router is connected.

Format `show ip pimsm componenttable`

Mode Privileged EXEC and User EXEC

Component Index This field displays a number which uniquely identifies the component.

Component BSR Address This field displays the IP address of the bootstrap router (BSR) for the local PIM region.

Component BSR Expiry Time This field displays the minimum time remaining before the BSR in the local domain will be declared down.

Component CRP Hold Time This field displays the hold time of the component when it is a candidate.

13.5.16 show ip pimsm interface

This command displays the interface information for PIM-SM on the specified interface.

Format `show ip pimsm interface <unit/slot/port>`

Mode Privileged EXEC and User EXEC

Unit/Slot/Port Valid unit, slot and port number separated by forward slashes.

IP Address This field indicates the IP address of the specified interface.

Subnet Mask This field indicates the Subnet Mask for the IP address of the PIM interface.

Mode This field indicates whether PIM-SM is enabled or disabled on the specified interface.

This is a configured value. By default it is disabled.

Hello Interval This field indicates the frequency at which PIM hello messages are transmitted on this interface. This is a configured value. By default, the value is 30 seconds.

CBSR Preference This field shows the preference value for the local interface as a candidate bootstrap router. This is a configured value.

CRP Preference This field shows the preference value as a candidate rendezvous point on this interface.

CBSR Hash Mask Length This field shows the hash mask length to be advertised in bootstrap messages if this interface is elected as the bootstrap router. The value is used in the hash algorithm for selecting the RP for a particular group.

13.5.17 show ip pimsm interface stats

This command displays the statistical information for PIM-SM on the specified interface.

Format `show ip pimsm interface stats {<unit/slot/port> | all}`

Mode Privileged EXEC and User EXEC

Unit/Slot/Port Valid unit, slot and port number separated by forward slashes.

IP Address This field indicates the IP Address that represents the PIM-SM interface.

Subnet Mask This field indicates the Subnet Mask of this PIM-SM interface.

Designated Router This indicates the IP Address of the Designated Router for this interface.

Neighbor Count This field displays the number of neighbors on the PIM-SM interface.

13.5.18 show ip pimsm neighbor

This command displays the neighbor information for PIM-SM on the specified interface.

Format show ip pimsm neighbor {<unit/slot/port> | all}

Mode Privileged EXEC and User EXEC

Unit/Slot/Port Valid unit, slot and port number separated by forward slashes.

IP Address This field displays the IP Address of the neighbor on an interface.

Up Time This field indicates the time since this neighbor has become active on this interface

Expiry Time This field indicates the expiry time of the neighbor on this interface.

13.5.19 show ip pimsm rp

This command displays the PIM information for candidate Rendezvous Points (RPs) for all IP multicast groups or for the specific <groupaddress> <groupmask> provided in the command. The information in the table is displayed for each IP multicast group.

Format show ip pimsm rp {<groupaddress> <groupmask> | candidate | all}

Mode Privileged EXEC and User EXEC

Group Address This field specifies the IP multicast group address.

Group Mask This field specifies the multicast group address subnet mask.

Address This field displays the IP address of the Candidate-RP.

Hold Time This field displays the hold time of a Candidate-RP.

Expiry Time This field displays the minimum time remaining before the Candidate-RP will be declared down.

Component This field displays a number which uniquely identifies the component. Each protocol instance connected to a separate domain should have a different index value.

13.5.20 show ip pimsm rphash

This command displays the RP router that will be selected from the set of active RP routers. The RP router, for the group, is selected by using the hash algorithm defined in RFC 2362.

Format show ip pimsm rphash <groupaddress>

Mode Privileged EXEC and User EXEC

CRP IP Address This field displays the IP address of the RP.

Group Mask This field displays the group mask for the group address.

14.0 Using the Web Interface

This chapter is a brief introduction to the web. You can manage your switch through a Web browser and Internet connection. This is referred to as Web-based management. To access the switch, the Web browser must support:

- HTML version 4.0, or later □
- HTTP version 1.1, or later □
- JavaScript^(TM) version 1.2, or later

This section explains how to access the switch Web-based management panels to configure and manage the switch.

It is important to note that there are equivalent functions in the Web interface as in the terminal interface (that is, there are usually the same menus to accomplish a task). For example, when you log in, there is a Main Menu with the same functions available, and so on. To terminate the Web login session, close the web browser.

There are several differences between the Web and terminal interfaces. For example, on the Web interface the entire forwarding database can be displayed, and the terminal interface only displays 10 entries starting at specified addresses.

14.1 Configuring for Web Access

To enable Web access to the switch:

- 1 Configure the switch for in-band connectivity.
- 2 Enable HTTP Web mode. For layer 2, see 'ip http server' command.

14.1.1 Web Page Layout

A Web interface panel for the switch Web page consists of three frames (Figure 3).

Frame 1, across the top, displays a banner graphic of the switch.

Frame 2, at the bottom-left displays a hierarchical-tree view. The tree consists of a combination of folders, subfolders, and configuration and status HTML pages. You can think of the folders and subfolders as branches and the configuration and status HTML pages as leaves. Only the selection of a leaf (not a folder or subfolder) will cause Frame 2 to display a new HTML page. A folder or subfolder has no corresponding Frame 3 HTML page.

Frame 3, the bottom-right frame, displays the currently selected device configuration status or the user configurable information that you have selected from the tree view of Frame 2, or both. You can resize each of these frames. There are no fixed-sized frames.

Figure 3. Web Interface Panel-Example

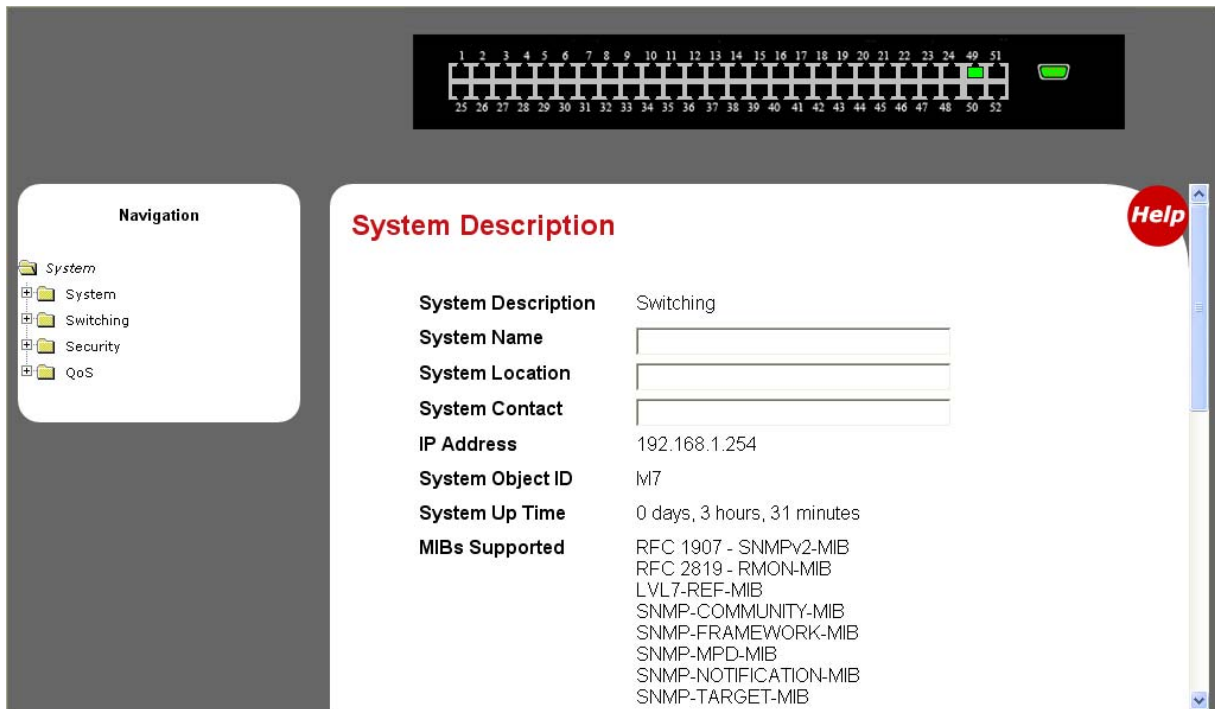

14.1.2 Starting the Web Interface

Note: You must configure the IP address of the switch before using the Web interface.

Follow these steps to bring up the switch Web interface:

- 1 Enter the IP address of the switch in the Web browser address field.
- 2 When the Login panel is displayed, enter the appropriate User Name and Password. The User Name and associated password are the same ones used for the terminal interface. Click on the Login button. The navigation tree is displayed in Frame 2, and the System Description Menu is displayed in Frame 3.
- 3 Make your selection by clicking on the appropriate item in the navigation tree in Frame 2.

14.1.3 Command Buttons

The following command buttons are used throughout the Web interface panels for the switch:

- Save** Implements and saves the changes you just made. Some settings may require you to reset the system in order for them to take effect.
- Refresh** The Refresh button that appears next to the Apply button in Web interface panels refreshes the data on the panel.
- Submit** Send the updated configuration to the switch. Configuration changes take effect immediately. These changes will not be retained across a power cycle unless a save is performed.

Glossary

Numerics

802.1D. The IEEE designator for Spanning Tree Protocol (STP). STP, a link management protocol, is part of the 802.1D standard for media access control bridges. Using the spanning tree algorithm, STP provides path redundancy while preventing endless loops in a network. An endless loop is created by multiple active paths between stations where there are alternate routes between hosts. To establish path redundancy, STP creates a logical tree that spans all of the switches in an extended network, forcing redundant paths into a standby, or blocked, state. STP allows only one active path at a time between any two network devices (this prevents the loops) but establishes the redundant links as a backup if the initial link should fail. If STP costs change, or if one network segment in the STP becomes unreachable, the spanning tree algorithm reconfigures the spanning tree topology and reestablishes the link by activating the standby path. Without spanning tree in place, it is possible that both connections may be simultaneously live, which could result in an endless loop of traffic on the LAN.

802.1P. The IEEE protocol designator for Local Area Network (LAN). This Layer 2 network standard improves support of time critical traffic, and limits the extent of high bandwidth multicast traffic within a bridged LAN. To do this, 802.1P defines a methodology for introducing traffic class priorities. The 802.1P standard allows priority to be defined in all 802 MAC protocols (Ethernet, Token Bus, Token Ring), as well as in FDDI. For protocols (such as Ethernet) that do not contain a priority field, 802.1P specifies a method for indicating frame priority based on the new fields defined in the 802.1Q (VLAN) standard.

802.1Q VLAN. The IEEE protocol designator for Virtual Local Area Network (VLAN). This standard provides VLAN identification and quality of service (QoS) levels. Four bytes are added to an Ethernet frame to allow eight priority levels (QoS) and to identify up to 4096 VLANs. See “VLAN” on page 302 for more information.

A

ABR. See “Area Border Router” on page 294.

Access Control List. An ACL is a database that an Operating System uses to track each user’s access rights to system objects (such as file directories and/or files).

ACL. See “Access Control List” on page 294.

Address Resolution Protocol. An Internet Protocol that dynamically maps Internet addresses to physical (hardware) addresses on a LAN.

Advanced Network Device Layer/Software. Our devise’s term for the Device Driver level.

Aging. When an entry for a node is added to the lookup table of a switch, it is given a timestamp. Each time a packet is received from a node, the timestamp is updated. The switch has a user-configurable timer that erases the entry after a certain length of time with no activity from that node.

API. See “Application Programming Interface” on page 294.

Application Programming Interface. An API is an interface used by an programmer to interface with functions provided by an application.

Area Border Router. A router located on the border of one or more OSPF areas that connects those areas to the backbone network. ABRs are considered members of both the OSPF backbone and the attached areas. They therefore maintain routing tables describing both the backbone topology and the topology of the other areas.

ARP. See “Address Resolution Protocol” on page 294.

ASAM. See “ATM Subscriber Access Multiplexer” on page 294.

ASBR. See “Autonomous System Boundary Router” on page 294.

ATM Subscriber Access Multiplexer. A telephone central office multiplexer that supports SDL ports over a wide range of network interfaces. An ASAM sends and receives subscriber data (often Internet services) over existing copper telephone lines, concentrating all traffic onto a single high-speed trunk for transport to the Internet or the enterprise intranet. This device is similar to a DSLAM (different manufacturers use different terms for similar devices).

Autonomous System Boundary Router. ABR located between an OSPF autonomous system and a non-OSPF network. ASBRs run both OSPF and another routing protocol, such as RIP. ASBRs must reside in a non-stub OSPF area. See also ABR, non-stub area, and OSPF.

AVL tree. Binary tree having the property that for any node in the tree, the difference in height between the left and right sub-trees of that node is no more than 1.

B

BPDU. See “Bridge Protocol Data Unit” on page 295.

BGP. See “Border Gateway Protocol” on page 295.

BootP. See “Bootstrap Protocol.” on page 295.

Bootstrap Protocol. An Internet protocol that enables a diskless workstation to discover its own IP address, the IP address of a BootP server on the network, and a file to be loaded into memory to boot the machine. This enables the workstation to boot without requiring a hard or floppy disk drive.

Border Gateway Protocol. BGP is a protocol for exchanging routing information between gateway host (each with its own router) in a network of autonomous systems. BGP is often the protocol used between gateway hosts on the Internet. The routing table contains a list of known routers, the addresses they can reach, and a cost metric associated with the path to each router so that the best available route is chosen. Hosts using BGP communicate using the Transmission Control Protocol (TCP) and send updated router table information only when one host has detected a change. Only the affected part of the routing table is sent. BGP-4, the latest version, lets administrators configure cost metrics based on policy statements. (BGP-4 is sometimes called BGP4, without the hyphen.) BGP communicates with autonomous (local) networks using Internal BGP (IBGP) since it doesn't work well with IGP. The routers inside the autonomous network thus maintain two routing tables: one for the interior gateway protocol and one for IBGP. BGP-4 makes it easy to use Classless Inter-Domain Routing (Classless Inter-Domain Routing), which is a way to have more addresses within the network than with the current IP address assignment scheme.

Bridge Protocol Data Unit. BPDU is the IEEE 802.1D MAC Bridge Management protocol that is the standard implementation of STP (Spanning Tree Protocol). It uses the STP algorithm to insure that physical loops in the network topology do not result in logical looping of network traffic. Using one bridge configured as root for reference, the BPDU switches one of two bridges forming a network loop into standby mode, so that only one side of a potential loop passes traffic. By examining frequent 802.1d configuration updates, a bridge in the standby mode can switch automatically into the forward mode if the other bridge forming the loop fails.

cards.h. A file that instructs the base code driver how to construct the driver.

card_db. A database that contains everything from port maps to module information.

Checksum. A simple error-detection scheme in which each transmitted message is identified with a numerical value based on the number of set bits in the message. The receiving station then applies a formula to the message and checks to make sure the accompanying numerical value is the same. If not, the receiver can assume that the message has been corrupted.

CLI. See “Command Line Interface” on page 295.

Command Line Interface. CLI is a line-item interface for configuring systems. (In the case of our switch, it is one of the user interfaces they have programmed for allowing programmers to configure their system).

Common Open Policy Service Protocol. A proposed standard protocol for exchanging network policy information between a Policy Decision Point (PDP) in a network and Policy Enforcement Points (PEPs) as part of overall Quality of Service (QoS) - the allocation of network traffic resources according to desired priorities of service. The policy decision point might be a network server controlled directly by the network administrator who enters policy statements about which kinds of traffic (voice, bulk data, video, teleconferencing, and so forth) should get the highest priority. The policy enforcement points might be router or layer 3 switches that implement the policy choices as traffic moves through the network. Currently, COPS is designed for use with the Resource Reservation Protocol (RSVP), which lets you allocate traffic priorities in advance for temporary high-bandwidth requirements (for example, video broadcasts or multicasts). It is possible that COPS will be extended to be a general policy communications protocol.

Complex Programmable Logic Device. CPLD is a programmable circuit on which a logic network can be programmed after its construction.

COPS. See "Common Open Policy Service Protocol." on page 295.

CPLD. See "Complex Programmable Logic Device." on page 295.

D

DAPI. See "Device Application Programming Interface" on page 295.

Device Application Programming Interface. DAPI is the software interface that facilitates communication of both data and control information between the Application Layer and HAPI, with support from System Support.

DHCP. See "Dynamic Host Configuration Protocol." on page 296.

Differentiated Services. Diffserv is a protocol for specifying and controlling network traffic by class so that certain types of traffic get precedence - for example, voice traffic, which requires a relatively uninterrupted flow of data, might get precedence over other kinds of traffic. Differentiated Services is the most advanced method for managing traffic in terms of what is called Class of Service (CoS). Unlike the earlier mechanisms of 802.1P tagging and Type of Service (ToS), Differentiated Services avoids simple priority tagging and depends on more complex policy or rule statements to determine how to forward a given network packet. An analogy is made to travel services, in which a person can choose among different modes of travel - train, bus, airplane - degree of comfort, the number of stops on the route, standby status, the time of day or period of year for the trip, and so forth. For a given set of packet travel rules, a packet is given one of 64 possible forwarding behaviors - known as per hop behaviors (PHBs). A six-bit field, known as the Differentiated Services Code Point (DSCP), in the Internet Protocol (Internet Protocol) header specifies the per hop behavior for a given flow of packets. Differentiated Services and the Class of Service approach provide a way to control traffic that is both more flexible and more scalability than the Quality of Service approach.

Diffserv. See "Differentiated Services." on page 296..

Distance-Vector Multicast Routing Protocol. DVMRP is a distance vector routing protocol used between routers in an intranet. This hop-based protocol describes a method of building multicast trees from the multicast source to all the receivers (or leaves) of the tree.

DVMRP. See "Distance-Vector Multicast Routing Protocol." on page 296.

Dynamic Host Configuration Protocol. DHCP is a protocol for assigning dynamic IP addresses to devices on a network. With dynamic addressing, a device can have a different IP address every time it connects to the network. In some systems, the device's IP address can even change while it is still connected. DHCP also supports a mix of static and dynamic IP addresses. Dynamic addressing simplifies

network administration because the software tracks IP addresses rather than requiring an administrator to manage the task. A new computer can be added to a network without the hassle of manually assigning it a unique IP address.

E

EEPROM. See “Electronically Erasable Programmable Read Only Memory” on page 296.

Electronically Erasable Programmable Read Only Memory. EEPROM is also known as Flash memory. This is re-programmable memory.

F

Fast STP. A high-performance Spanning Tree Protocol. See “STP” on page 301 for more information.

FIFO. First In First Out.

Flash Memory. See “EEPROM” on page 296.

Flow Control. The process of adjusting the flow of data from one network device to another to ensure that the receiving device can handle all of the incoming data. This is particularly important where the sending device is capable of sending data much faster than the receiving device can receive it. There are many flow control mechanisms. One of the most common flow control protocols for asynchronous communication is called xonxoff. In this case, the receiving device sends a an “xoff” message to the sending device when its buffer is full. The sending device then stops sending data. When the receiving device is ready to receive more data, it sends an “xon” signal.

Forwarding. When a frame is received on an input port on a switch, the address is checked against the lookup table. If the lookup table has recorded the destination address, the frame is automatically forwarded on an output port.

Frame Check Sequence. The extra characters added to a frame for error detection and correction. FCS is used in X.25, HDLC, Frame Relay, and other data link layer protocols.

G

GARP. See “Generic Attribute Registration Protocol.” on page 297.

GARP Information Propagation. GIP is the propagation of information between GARP participants for the same application in a bridge is carried out by a GIP component.

GARP Multicast Registration Protocol. GMRP provides a mechanism that allows Bridges and end stations to dynamically register (and subsequently, de-register) Group membership information with the MAC Bridges attached to the same LAN segment, and for that information to be disseminated across all Bridges in the Bridged LAN that support Extended Filtering Services. The operation of GMRP relies upon the services provided by the GARP.

GARP VLAN Registration Protocol. GVRP allows workstations to request admission to a particular VLAN for multicast purposes.

GE. See “Gigabit Ethernet” on page 297.

General Purpose Chip-select Machine. GPCM provides interfacing for simpler, lower-performance memory resources and memory mapped-devices. The GPCM does not support bursting and is used primarily for boot-loading.

Generic Attribute Registration Protocol. GARP provides a generic attribute dissemination capability that is used by participants in GARP Applications (called GARP Participants) to register and de-register attribute values with other GARP Participants within a Bridged LAN. The definition of the attribute types, the values that they can carry, and the semantics that are associated with those values when registered

are specific to the operation of the GARP Application concerned.

Gigabit Ethernet. A high-speed Ethernet connection.

GIP. See “GARP Information Propagation” on page 296.

GMRP. See “GARP Multicast Registration Protocol” on page 296.

GPCM. See “General Purpose Chip-select Machine” on page 297.

GVD. GARP VLAN Database.

GVRP. See “GARP VLAN Registration Protocol.” on page 297.

H

.h file. Header file in C code. Contains function and coding definitions.

HAPI. See “Hardware Abstraction Programming Interface” on page 297.

Hardware Abstraction Programming Interface. HAPI is the module that contains the NP specific software that interacts with the hardware.

hop count. The number of routers that a data packet passes through on its way to its destination.

I

ICMP. See “Internet Control Message Protocol” on page 297.

IGMP. See “Internet Group Management Protocol” on page 297.

IGMP Snooping. A series of operations performed by intermediate systems to add logic to the network to optimize the flow of multicast traffic; these intermediate systems (such as Layer 2 switches) listen for IGMP messages and build mapping tables and associated forwarding filters, in addition to reducing the IGMP protocol traffic. See “Internet Group Management Protocol” on page 297 for more information.

Internet Control Message Protocol. ICMP is an extension to the Internet Protocol (IP) that supports packets containing error, control, and informational messages. The PING command, for example, uses ICMP to test an Internet connection.

Internet Group Management Protocol. IGMP is the standard for IP Multicasting on the Internet. IGMP is used to establish host memberships in particular multicast groups on a single network. The mechanisms of the protocol allow a host to inform its local router, using Host Membership Reports, that it wants to receive messages addressed to a specific multicast group. All hosts conforming to Level 2 of the IP Multicasting specification require IGMP.

IP. See “Internet Protocol” on page 297.

IP Multicasting. Sending out data to distributed servers on the Mbone (Multicast Backbone). For large amounts of data, IP Multicast is more efficient than normal Internet transmissions because the server can broadcast a message to many recipients simultaneously. Unlike traditional Internet traffic that requires separate connections for each source-destination pair, IP Multicasting allows many recipients to share the same source. This means that just one set of packets is transmitted for all the destinations.

Internet Protocol. The method or protocol by which data is sent from one computer to another on the Internet. Each computer (known as a host) on the Internet has at least one IP address that uniquely identifies it among all other computers on the Internet. When you send or receive data (for example, an e-mail note or a Web page), the message gets divided into little chunks called packets. Each of these packets contains both the sender's Internet address and the receiver's address. Any packet is sent first to a gateway computer that understands a small part of the Internet. The gateway computer reads the destination address and forwards the packet to an adjacent gateway that in turn reads the destination address and so forth

across the Internet until one gateway recognizes the packet as belonging to a computer within its immediate neighborhood or domain. That gateway then forwards the packet directly to the computer whose address is specified.

Because a message is divided into a number of packets, each packet can, if necessary, be sent by a different route across the Internet. Packets can arrive in a different order than they were sent. The Internet Protocol just delivers them. It's up to another protocol, the Transmission Control Protocol (TCP) to put them back in the right order. IP is a connectionless protocol, which means that there is no continuing connection between the end points that are communicating. Each packet that travels through the Internet is treated as an independent unit of data without any relation to any other unit of data. (The reason the packets do get put in the right order is because of TCP, the connection-oriented protocol that keeps track of the packet sequence in a message.) In the Open Systems Interconnection (OSI) communication model, IP is in Layer 3, the Networking Layer. The most widely used version of IP today is IP version 4 (IPv4). However, IP version 6 (IPv6) is also beginning to be supported. IPv6 provides for much longer addresses and therefore for the possibility of many more Internet users. IPv6 includes the capabilities of IPv4 and any server that can support IPv6 packets can also support IPv4 packets.

IVL. Independent VLAN Learning (IVL) allows unicast address-to-port mappings to be created based on a MAC Address in conjunction with a VLAN ID.

. J

Joint Test Action Group. An IEEE group that specifies test framework standards for electronic logic components.

JTAG. See "Joint Test Action Group" on page 298.

LAN. See "Local Area Network" on page 298.

LDAP. See "Lightweight Directory Access Protocol" on page 298.

Lightweight Directory Access Protocol. A set of protocols for accessing information directories. LDAP is based on the standards contained within the X.500 standard, but is significantly simpler. Unlike X.500, LDAP supports TCP/IP, which is necessary for any type of Internet access. Although not yet widely implemented, LDAP should eventually make it possible for almost any application running on virtually any computer platform to obtain directory information, such as e-mail addresses and public keys. Because LDAP is an open protocol, applications need not worry about the type of server hosting the directory.

Learning. The bridge examines the Layer 2 source addresses of every frame on the attached networks (called listening) and then maintains a table, or cache, of which MAC addresses are attached to each of its ports.

Link-State. In routing protocols, the declared information about the available interfaces and available neighbors of a router or network. The protocol's topological database is formed from the collected link-state declarations.

Local Area Network. A group of computers that are located in one area and are connected by less than 1,000 feet of cable. A typical LAN might interconnect computers and peripherals on a single floor or in a single building. LANs can be connected together, but if modems and telephones connect two or more LANs, the larger network constitutes what is called a WAN or Wide Area Network.

M

MAC. (1) Medium Access Control. In LANs, the sub-layer of the data link control sublayer that supports medium-dependent functions and uses the services of the physical layer to provide services to the logical link control (LLC) sublayer. The MAC sublayer includes the method of determining when a device has access to the transmission medium. (2) Message Authentication Code. In computer security, a value that is a part of a message or accompanies a message and is used to determine that the contents, origin,

author, or other attributes of all or part of the message are as they appear to be. (*IBM Glossary of Computing Terms*)

Management Information Base. When SNMP devices send SNMP messages to the management console (the device managing SNMP messages), it stores information in the MIB.

MBONE. See “Multicast Backbone” on page 299.

MDC. Management Data Clock.

MDI. Management Data Interface.

MDIO. Management Data Input/Output.

MDIX. Management Dependent Interface Crossover.

MIB. See “Management Information Base” on page 298.

MOSPF. See “Multicast OSPF” on page 299.

MPLS. See “Multi-Protocol Label Switching” on page 299.

Multicast Backbone. The MBONE is a virtual network. It is layered on top of portions of the physical Internet to support routing of IP multicast packets since that function has not yet been integrated into many production routers. The network is composed of islands that can directly support IP multicast, such as multicast LANs like Ethernet, linked by virtual point-to-point links called “tunnels”. The tunnel endpoints are typically workstation-class machines having operating system support for IP multicast and running the “mouted” multicast routing daemon.

Multicasting. To transmit a message to specific recipients across a network. A simple example of multicasting is sending an e-mail message to a mailing list. Teleconferencing and videoconferencing also use multicasting, but require more robust protocols and networks. Standards are being developed to support multicasting over a TCP/IP network such as the Internet. These standards, IP Multicast and Mbone, will allow users to easily join multicast groups. Note that multicasting refers to sending a message to a select group whereas broadcasting refers to sending a message to everyone connected to a network. The terms multicast and narrowcast are often used interchangeably, although narrowcast usually refers to the business model whereas multicast refers to the actual technology used to transmit the data.

Multicast OSPF. With a MOSPF specification, an IP Multicast packet is routed based both on the packet’s source and its multicast destination (commonly referred to as source/destination routing). As it is routed, the multicast packet follows a shortest path to each multicast destination. During packet forwarding, any commonality of paths is exploited; when multiple hosts belong to a single multicast group, a multicast packet will be replicated only when the paths to the separate hosts diverge. See “OSPF” on page 300 for more information.

Multiplexing. A function within a layer that interleaves the information from multiple connections into one connection.

Multi-Protocol Label Switching. An initiative that integrates Layer 2 information about network links (bandwidth, latency, utilization) into Layer 3 (IP) within a particular autonomous system—or ISP—in order to simplify and improve IP-packet exchange. MPLS gives network operators a great deal of flexibility to divert and route traffic around link failures, congestion, and bottlenecks. From a QoS standpoint, ISPs will better be able to manage different kinds of data streams based on priority and service plan. For instance, those who subscribe to a premium service plan, or those who receive a lot of streaming media or high-bandwidth content can see minimal latency and packet loss. When packets enter into a MPLS-based network, Label Edge Routers (LERs) give them a label (identifier). These labels not only contain information based on the routing table entry (i.e., destination, bandwidth, delay, and other metrics), but also refer to the IP header field (source IP address), Layer 4 socket number information, and differentiated service. Once this classification is complete and mapped, different packets are assigned to corresponding Labeled Switch Paths (LSPs), where Label Switch Routers (LSRs) place outgoing labels on the packets. With these LSPs, network operators can divert and route traffic based on data-stream

type and Internet-access customer.

MT-RJ connector. A type of fiber-optic cable jack that is similar in shape and concept to a standard telephone jack, enabling duplex fiber-optic cables to be plugged into compatible devices as easily as plugging in a telephone cable.

MUX. See “Multiplexing” on page 299.

N

NAT. See “Network Address Translation” on page 299.

Network Address Translation. Sometimes referred to as Transparent Proxying, IP Address Overloading, or IP Masquerading. Involves use of a device called a Network Address Translator, which assigns a contrived, or logical, IP address and port number to each node on an organization's internal network and passes packets using these assigned addresses.

NM. Network Module.

nm. Nanometer (1×10^9) meters.

non-stub area. Resource-intensive OSPF area that carries a default route, static routes, intra-area routes, inter area routes, and external routes. Non-stub areas are the only OSPF areas that can have virtual links configured across them, and are the only areas that can contain an ASBR. Compare with stub area. See also ASAM and OSPF.

NP. Network Processor.

O

Open Shortest Path First. A link- state (algorithm used by the router to determine the current topology of a network), Interior Gateway (distributes routing information between routers belonging to a single Autonomous System) routing protocol. This protocol's algorithm determines the shortest path from its router to all the other routers in the network. This protocol is rapidly replacing RIP on the Internet.

Open Systems Interconnection. OSI is a seven (7) layer architecture model for communications systems developed by the ISO for the interconnection of data communications systems. Each layer uses and builds on the services provided by those below it.

Operating System Application Programming Interface. OSAPI is a module within the System Support software that provides a set of interfaces to OS support functions.

OS. Operating System.

OSAPI. See “Operating System Application Programming Interface” on page 300.

OSI. See “Open Systems Interconnection” on page 300.

OSPF. See “Open Shortest Path First” on page 300.

P

PDU. See “Protocol Data Unit” on page 300.

PHY. The OSI Physical Layer: The physical layer provides for transmission of cells over a physical medium connecting two ATM devices. This physical layer is comprised of two sublayers: the Physical Medium Dependent (PMD) sublayer, and the Transmission Convergence (TC) sublayer.

PIM-DM. See “Protocol Independent Multicast – Dense Mode” on page 300.

PMC. Packet Mode Channel.

Port Mirroring. Also known as a roving analysis port. This is a method of monitoring network traffic that forwards a copy of each incoming and outgoing packet from one port of a network switch to another port where the packet can be studied. A network administrator uses port mirroring as a diagnostic tool or debugging feature, especially when fending off an attack. It enables the administrator to keep close track of switch performance and alter it if necessary. Port mirroring can be managed locally or remotely. An administrator configures port mirroring by assigning a port from which to copy all packets and another port where those packets will be sent.

A packet bound for or heading away from the first port will be forwarded onto the second port as well. The administrator places a protocol analyzer on the port receiving the mirrored data to monitor each segment separately. The analyzer captures and evaluates the data without affecting the client on the original port. The monitor port may be a port on the same SwitchModule with an attached RMON probe, a port on a different SwitchModule in the same hub, or the SwitchModule processor. Port mirroring can consume significant CPU resources while active. Better choices for long-term monitoring may include a passive tap like an optical probe or an Ethernet repeater.

Protocol Data Unit. PDU is a packet of data passed across a network. The term implies a specific layer of the OSI model and a specific protocol.

Protocol Independent Multicast – Dense Mode. Like DVMRP, PIM-DM uses a flood and prune protocol for building multicast trees. However, unlike DVMRP, PIMDM uses existing unicast protocols for determining the route to the source.

Q

QoS. See “Quality of Service” on page 300.

Quality of Service. QoS is a networking term that specifies a guaranteed level of throughput. Throughput is the amount of data transferred from one device to another or processed in a specified amount of time - typically, throughputs are measured in bytes per second (Bps).

R

Real-Time Operating System. RTOS is a component of the OSAPI module that abstracts operating systems with which other systems can interface.

Resource Reservation Setup Protocol. RSVP is a new Internet protocol being developed to enable the Internet to support specified Qualities-of-Service (QoS). Using RSVP, an application will be able to reserve resources along a route from source to destination. RSVP-enabled routers will then schedule and prioritize packets to meet the prioritization assigned by QoS. RSVP is a chief component of a new type of Internet being developed, known broadly as an integrated services Internet. The general idea is to enhance the Internet to support transmission of real-time data.

RFC. Request For Comment.

RIP. See “Routing Information Protocol” on page 301.

Routing Information Protocol. RIP is the routing protocol used by the routed process on Berkeley-derived UNIX systems. Many networks use RIP; it works well for small, isolated, and topologically simple networks.

RIPng. Routing Information Protocol, new generation.

RMON. Short for remote monitoring, a network management protocol that allows network information to be gathered at a single workstation. Whereas SNMP gathers network data from a single type of Management Information Base (MIB), RMON 1 defines nine additional MIBs that provide a much richer set of data about network usage. For RMON to work, network devices, such as hubs and switches, must be designed to support it. The newest version of RMON, RMON 2, provides data about traffic at the network layer in addition to the physical layer. This allows administrators to analyze traffic by protocol.

RP. Rendezvous Point. Used with IP Multicast.

RPU. Remote Power Unit.

RSVP. See “Resource Reservation Setup Protocol” on page 300.

RTOS. See “Real-Time Operating System” on page 300.

S

SDL. Synchronous Data Link.

Simple Network Management Protocol. SNMP is the protocol governing network management and the monitoring of network devices and their functions. It is not necessarily limited to TCP/IP networks. The versions have the following differences:

SNMPv1 (full): Security is based on community strings.

SNMPsec (historic): Security is based on parties. Few, if any, vendors implemented this version of the protocol, which is now largely forgotten.

SNMPv2p (historic): For this version, much work was done to update the *SNMPv1* protocol and the *SMIv1*, and not just security. The result was updated protocol operations, new protocol operations and data types, and party-based security from *SNMPsec*.

SNMPv2c (experimental): This version of the protocol is called community string-based *SNMPv2*. It is an update of the protocol operations and data types of *SNMPv2p*, and uses community-based security from *SNMPv1*.

SNMPv2u (experimental): This version of the protocol uses the protocol operations and data types of *SNMPv2c* and security based on users.

*SNMPv2** (experimental): This version combined the best features of *SNMPv2p* and *SNMPv2u*. (It is also called *SNMPv2star*.) The documents defining this version were never published as RFCs.

SNMPv3 (proposed): This version of the protocol is a combination of user-based security and the protocol operations and data types from *SNMPv2p* and support for proxies. The security is based on that found in *SNMPv2u* and *SNMPv2**, and updated after much review. The documents defining this protocol will soon be published as RFCs.

SimpleX signaling. SX is one of IEEE 802.3's designations for media. For example, 1000SX indicates 1000 gigabit Ethernet over "short haul" or "short wavelength" optical fiber.

SMC1. A model of Serial Management Controller from Motorola.

SMII. Serial Media Independent Interface.

SNMP. See “Simple Network Management Protocol” on page 301.

SODIMM. Small Outline Dual Inline Memory Module.

SRAM. Static Random Access Memory.

STP. Spanning Tree Protocol. See “802.1D” on page 294 for more information.

stub area. OSPF area that carries a default route, intra-area routes, and interarea routes, but does not carry external routes. Virtual links cannot be configured across a stub area, and they cannot contain an ASBR. Compare with non-stub area. See also ASAM and OSPF.

SVL. Most switches support Independent learning, wherein traffic from one VLAN will not be forwarded to another VLAN. Hence if some limited form of forwarding needs to be supported, the switch should implement Shared VLAN learning.

SX. See “SimpleX signaling” on page 301.

SYSAPI. See “Systems Application Programming Interface” on page 301.

Systems Application Programming Interface. SYSAPI is a module within the System Support software that provides system-wide routines for network and mbuf support and provides the interface into the system registry.

T

TBI. Ten Bit Interface.

Telnet. A character-based UNIX application that enables users with a Telnet server account to log on to a UNIX computer and utilize its resources.

TFTP. See “Trivial File Transfer Protocol” on page 302.

Trivial File Transfer Protocol. TFTP is a simple form of the File Transfer Protocol (FTP). TFTP uses the User Datagram Protocol (UDP, a direct protocol used to communicate datagrams over a network with little error recovery) and provides no security features. It is often used by servers to boot diskless workstations, X-terminals, and routers.

Trunking. The process of combing a set of trunks that are traffic-engineered as a unit for the establishment of connections between switching systems in which all of the communications paths are interchangeable.

U

UPM. User Programmable Machine.

UPMA. The first of two UPMs in Motorola's MPC855T processor.

UPMB. The second of two UPMs in Motorola's MPC855T processor.

USP. An abbreviation that represents Unit, Slot, Port.

Virtual Local Area Network. Operating at the Data Link Layer (Layer 2 of the OSI model), the VLAN is a means of parsing a single network into logical user groups or organizations, as if they physically resided on a dedicated LAN segment of their own. In reality, this virtually defined community may have individual members peppered across a large, extended LAN. The VLAN identifier is part of the 802.1Q tag, which is added to an Ethernet frame by an 802.1Q-compliant switch or router. Devices recognizing 802.1Q-tagged frames maintain appropriate tables to track VLANs. The first three bits of the 802.1Q tag are used by 802.1P to establish priority for the packet.

Virtual Router Redundancy Protocol. VRRP specifies an election protocol that dynamically assigns responsibility for a virtual router to one of the VRRP routers on a LAN. The VRRP router controlling the IP address(es) associated with a virtual router is called the Master, and forwards packets sent to these IP addresses. The election process provides dynamic fail-over in the forwarding responsibility should the Master become unavailable. This allows any of the virtual router IP addresses on the LAN to be used as the default first hop router by end-hosts. The advantage gained from using VRRP is a higher availability default path without requiring configuration of dynamic routing or router discovery protocols on every end-host.

VLAN. See “Virtual Local Area Network” on page 302.

vMAN. Virtual Metropolitan Area Network.

VRRP. See “Virtual Router Redundancy Protocol” on page 302.

W

WAN. See “Wide Area Network” on page 302.

Web. Also known as World-Wide Web (WWW) or W3. An Internet client-server system to distribute information, based upon the hypertext transfer protocol (HTTP).

Wide Area Network. A WAN is a computer network that spans a relatively large geographical area. Typically, a WAN consists of two or more local-area networks (LANs).

X

X.500. A directory standard that enables applications like e-mail to access information that can either be central or distributed. The benefit of a directory is the ability to minimize the impact on the user of changes to a network. The standard is broken down under subsequent standards, as follows:

X.501 Models

X.509 Authentication framework

X.511 Abstract service definition

X.518 Procedures for distributed operation

X.519 Protocol specifications

X.520 Selected attribute types

X.521 Selected object types

XModem. One of the most popular file transfer protocols (FTPs). Xmodem is fairly effective at detecting errors. It sends blocks of data together with a checksum and then waits for acknowledgment of the block's receipt. The waiting slows down the rate of data transmission considerably, but it ensures accurate transmission. Xmodem can be implemented either in software or in hardware. Many modems, and almost all communications software packages, support Xmodem. However, it is useful only at relatively slow data transmission speeds (less than 4,800 bps). Enhanced versions of Xmodem that work at higher transmission speeds are known as Ymodem and Zmodem.